

XPLORE 120/12 CHARGER DATASHEET



AVAILABLE IN:
12V 
120A

ALL CHARGING NEEDS IN ONE CHARGER

The XPLORE 120/12 Battery Charger is the largest and most powerful charger in the market today. The universal, auto-ranging AC input and 120 amps of output current ensures ultra-fast and reliable worldwide charging. With up to six output banks of simultaneous charging combined with the ability to charge two battery banks with differing chemistries, the XPLORE 120/12 eliminates the need to have separate single-chemistry chargers and minimizes installation and wiring costs for your house bank and engine bank.

It is also equipped with an easy-to-read front panel LED display for basic configuration and status information. Advanced monitoring and configuration is enabled by NMEA 2000 protocol or Xantrex app using the Xantrex BLE module.



Six battery bank charging



Ability to charge dead batteries down to 0V



Dual battery chemistry charging



NMEA 2000 monitoring and configuration



Designed to charge lithium batteries



Xantrex App monitoring and configuration

APPLICATIONS:



www.xantrex.com
CUSTOMER CARE: 1.800.670.0707



TOP VIEW

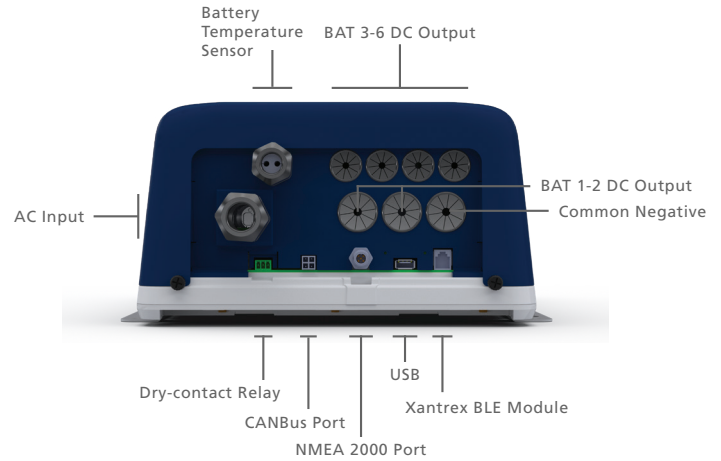

BOTTOM VIEW

PRODUCT FEATURES

6 Battery Banks and Dual-Chemistry Charging

- Simplifies system design by replacing multiple single-chemistry chargers with a single dual-chemistry charger to charge house banks and engine banks of differing chemistries.

Xantrex Lithium and Custom Battery Charging

- Selectable battery type pre-set optimized for Xantrex Lithium-Ion Batteries or configure a custom battery setting.

NMEA 2000 Connectivity

- Allows for real-time monitoring and configuration via multi-functional displays by leading marine multiplex manufacturers.

Xantrex App Connectivity

- Allows for real-time monitoring and configuration via the Xantrex mobile app using the Xantrex BLE module.

Power Share

- Automatically reduces charging output to prevent nuisance tripping of the AC input breaker.

Quiet Mode

- When enabled, the internal fan is turned off and the charger operates at a reduced output when quietness is needed.

Storage Mode

- Automatically refreshes your batteries once every several days of non-use to ensure optimal battery condition.

PAIR WITH XANTREX LITHIUM-ION BATTERIES

OPTIMALLY CHARGED WITH THE XPLORE 120/12



12V 105Ah XANTREX
LITHIUM-ION BATTERY
(883-0105-12)



12V 125Ah XANTREX
LITHIUM-ION BATTERY
(883-0125-12)



12V 240Ah XANTREX
LITHIUM-ION BATTERY
(883-0240-12)

ELECTRICAL SPECIFICATIONS

XPLORE 120/12	
Max Total BAT1-6 DC Output Current	120A
Max Total BAT1-2 DC Output Current	10 to 120A (selectable)
Max Total BAT3-6 DC Output Current	10 to 40A (selectable)
DC Output Voltage	12Vdc (nominal)
DC Output Connections	6
AC Input Voltage (Auto Ranging)	120Vac / 230Vac (nominal), 80 to 275Vac 60Hz / 50Hz (nominal), 45 to 65Hz
AC Input Current	19.6Aac (maximum)
Power Factor at Full Charge Rate	> 98%
Charging Modes	3-Stage, 2-Stage, Constant Voltage
Supported Battery Types	AGM, FLD, GEL, Xantrex LFP, Custom
Equalization (FLD Battery Only)	Yes

GENERAL SPECIFICATIONS

XPLORE 120/12	
Operating Temperature	4 to 140°F (-20 to 60°C), with output derated above 122°F (50°C)
Storage Temperature	-40 to 176°F (-40 to 80°C)
Operating Humidity	5 to 95% RH, non-condensing
AC Input Terminal Connection	3-position tool-free spring clamp terminal
DC Output Terminal Connection	BAT1-2: Two M6 stud terminals BAT3-6: Four M5 stud terminals Negative: One M6 stud terminal
Part Number	819-0120-12
Dimensions (L x W x H)	Charger: 16.26" (413mm) x 12.34" (312mm) x 6.5" (165mm) Xantrex BLE Module: 3.0" (75mm) x 2.0" (50mm) x 1.0" (24mm) 25' (7.6m) cable length
Net Weight	Charger: 16.3 lbs (7.4kg)
Ingress Protection (IP) Rating	Charger: IP-32 (vertical)

REGULATORY APPROVALS

XPLORE 120/12	
Safety	NRTL listed to CSA C22.2 No. 107.2, conforms to UL Std. UL1236 (with Marine Supplement) and UL1564, ABYC E-11, A-31
EMC	47 CFR (FCC) Part 15B, Class B, ISED, and CAN ICES-3(B) / NMB-3(B)
Ignition Protection	SAE J1171, ABYC C-1500

Specifications are subject to change without notice.

XPLORE 120/12 CHARGER DIMENSIONS

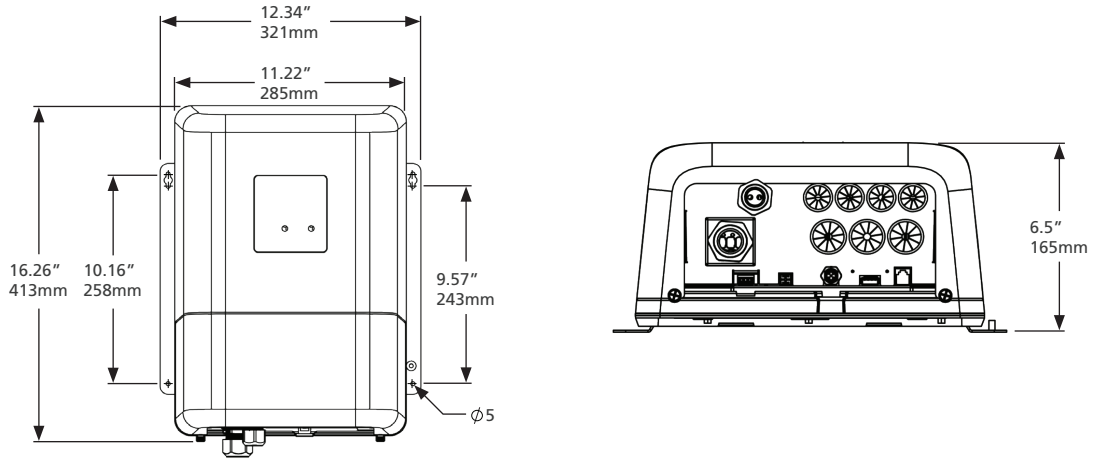

ACCESSORIES

Mfg Part #	Description
808-0232-01	BTS (battery temperature sensor)

NOTE: Contact Xantrex or your dealer to order these accessories.

CONTACT

CUSTOMER SERVICE

1.800.670.0707
 customerservice@xantrex.com
Hours of operation:
 6:30am - 4:30pm PST, Monday to Friday

 facebook.com/Xantrex

 [@Xantrex](https://twitter.com/Xantrex)

 youtube.com/XantrexTechnology

LEARN MORE ON:

www.xantrex.com