



samlexpower®

**Remote Control for
Evolution™ Series
Inverter/ Charger**

Model: EVO-RC-PLUS

**Owner's
Manual**

Please read this
manual **BEFORE**
operating.

Firmware
Version: 0.33

NOTE: REMOTE CONTROL MODEL NO. EVO-RC-PLUS IS OPTIONAL AND IS REQUIRED TO BE ORDERED SEPARATELY.

EVO-RC-PLUS OWNER'S MANUAL | Index

SECTION 1	
Introduction and Layout	3
SECTION 2	
Installation	6
SECTION 3	
Operation	8
SECTION 4	
Parameter Setup	38
SECTION 5	
SD Card	111
SECTION 6	
Monitoring of Operation Using LED and Buzzer	119
SECTION 7	
Fault Messages and Troubleshooting Guide	120
SECTION 8	
Specifications	125
SECTION 9	
Warranty	126

Disclaimer of Liability

UNLESS SPECIFICALLY AGREED TO IN WRITING, SAMLEX AMERICA INC.:

1. MAKES NO WARRANTY AS TO THE ACCURACY, SUFFICIENCY OR SUITABILITY OF ANY TECHNICAL OR OTHER INFORMATION PROVIDED IN ITS MANUALS OR OTHER DOCUMENTATION.
2. ASSUMES NO RESPONSIBILITY OR LIABILITY FOR LOSSES, DAMAGES, COSTS OR EXPENSES, WHETHER SPECIAL, DIRECT, INDIRECT, CONSEQUENTIAL OR INCIDENTAL, WHICH MIGHT ARISE OUT OF THE USE OF SUCH INFORMATION. THE USE OF ANY SUCH INFORMATION WILL BE ENTIRELY AT THE USERS RISK.

Samlex America reserves the right to revise this document and to periodically make changes to the content hereof without obligation or organization of such revisions or changes.

Copyright Notice/Notice of Copyright

Copyright © 2021 by Samlex America Inc. All rights reserved. Permission to copy, distribute and/or modify this document is prohibited without express written permission by Samlex America Inc.

SECTION 1 | Introduction and Layout

1.0 INTRODUCTION

EVO-RC-PLUS Remote Control is used to monitor and customize the operating parameters of Samlex EVO™ Inverter/Chargers Model (i) EVO-1212F / 1212F-HW / 1224F / 1224F-HW, (ii) EVO-2212 / 3012 / 2224 / 4024 (iii) EVO-2212E / 3012E / 2224E / 4024E and (iv) EVO-4248SP. Layout is shown in Fig 1 below.

It has its own internal Real Time Clock and Super Capacitor Type of Battery for clock operation.

1.1 LAYOUT AND DIMENSIONS

1. LCD Screen:
 - 4 rows of 20 characters each
 - Blue screen with white characters
2. ON/OFF Key
3. Blue LED "Status"
4. Red LED "Fault"
5. Navigation Key "Back"
6. Navigation Key "Up"
7. Navigation Key "Down"
8. Navigation Key "Enter"
9. SD Card Slot – FAT16/32 format, up to 32 GB

10. RJ-45 Jack (8P8C)

11. RJ-12 Jack (6P6C)

Pin #	Signal
1	12V
2	12V
3	ON/OFF
4	D+
5	D-
6	NC
7	GND
8	GND

Pin #	Signal
1	NC
2	GND
3	D-
4	D+
5	12
6	ON/OFF

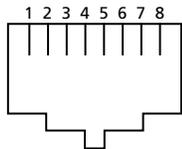

(View - Looking into the Jack)

(View - Looking into the Jack)

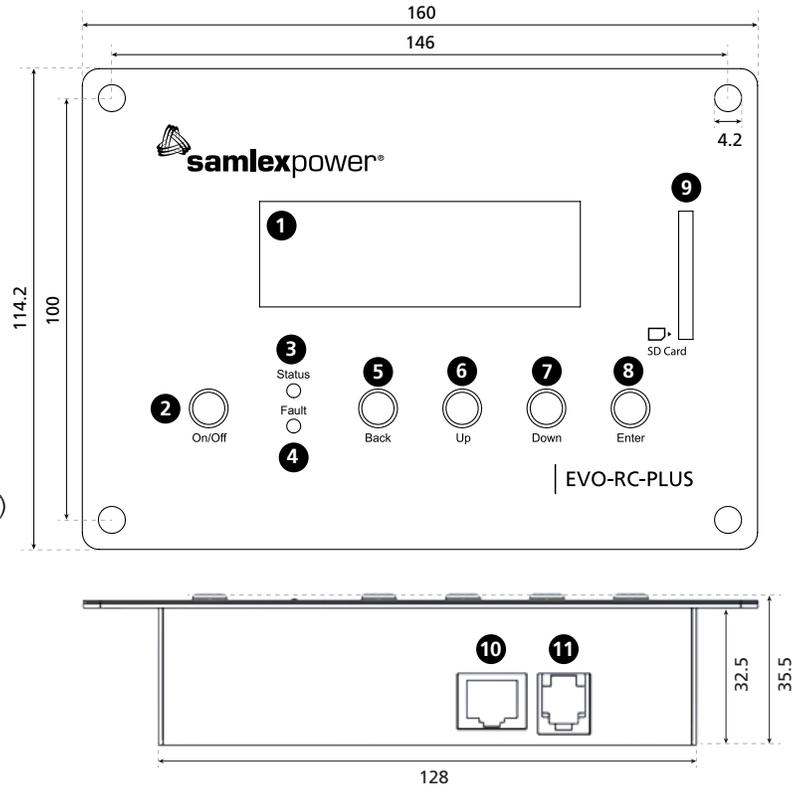

Fig 1.1 Layout & Dimensions of Remote Control Model EVO-RC-PLUS

1.2 CONNECTING CABLE

Details of connecting cable provided with the Remote Control are as follows:

- Length: 10m / 33ft
- No of conductors: 8
- Modular Plug: 8P8C, RJ-45
- Plug interconnection: Straight (*See Pinout at Fig 1.2*)

SECTION 1 | Introduction and Layout

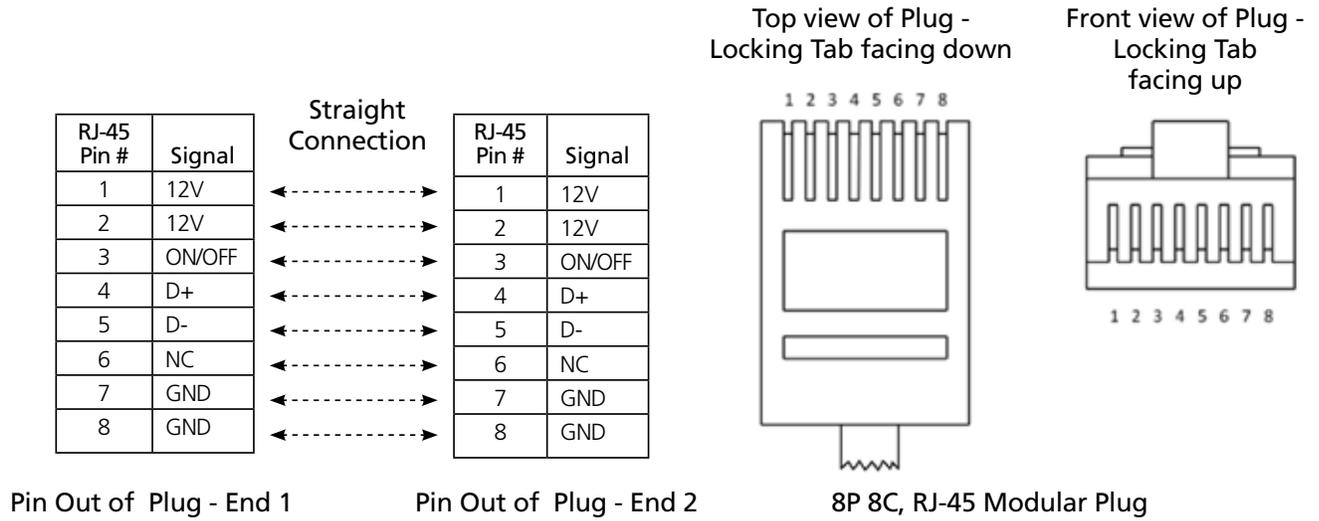

Fig 1.2 Pin Out of Plugs for 8P8C, RJ-45 Connecting Cable

1.3 PINOUT DIAGRAMS & INTERNAL INTERCONNECTION OF RJ-45 & RJ-12 JACKS

RJ-45 Jack (10, Fig 1.1) and RJ-12 Jack (11, Fig 1.1) are internally connected as pinout at Fig 1.3.

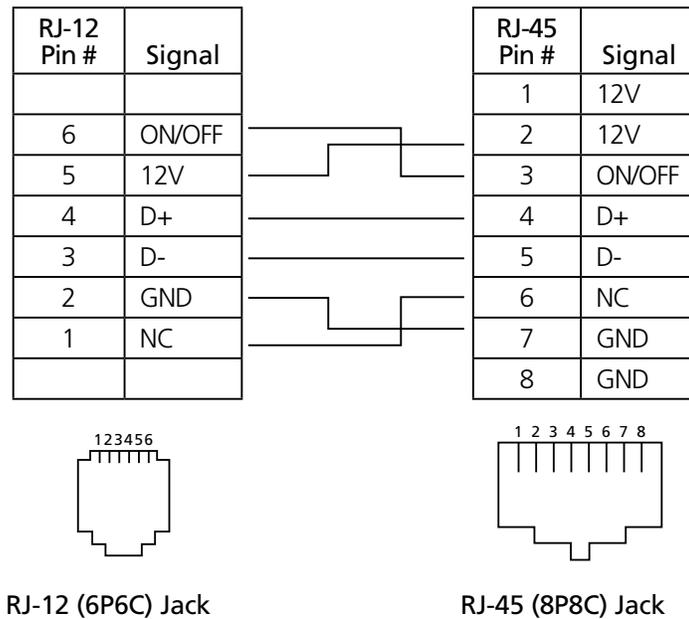

Fig 1.3 Pinout and internal interconnections of RJ-45 (8P8C) and RJ-12 (6P6C) Jacks on EVO-RC-PLUS

SECTION 1 | Introduction and Layout

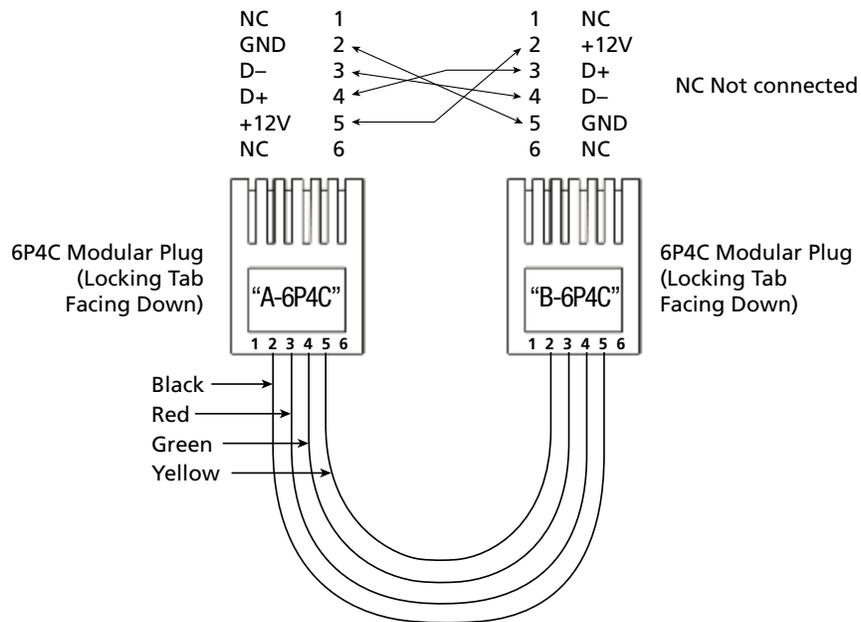

Fig 1.4 RJ-11 (6P4C) rolled over connected cable

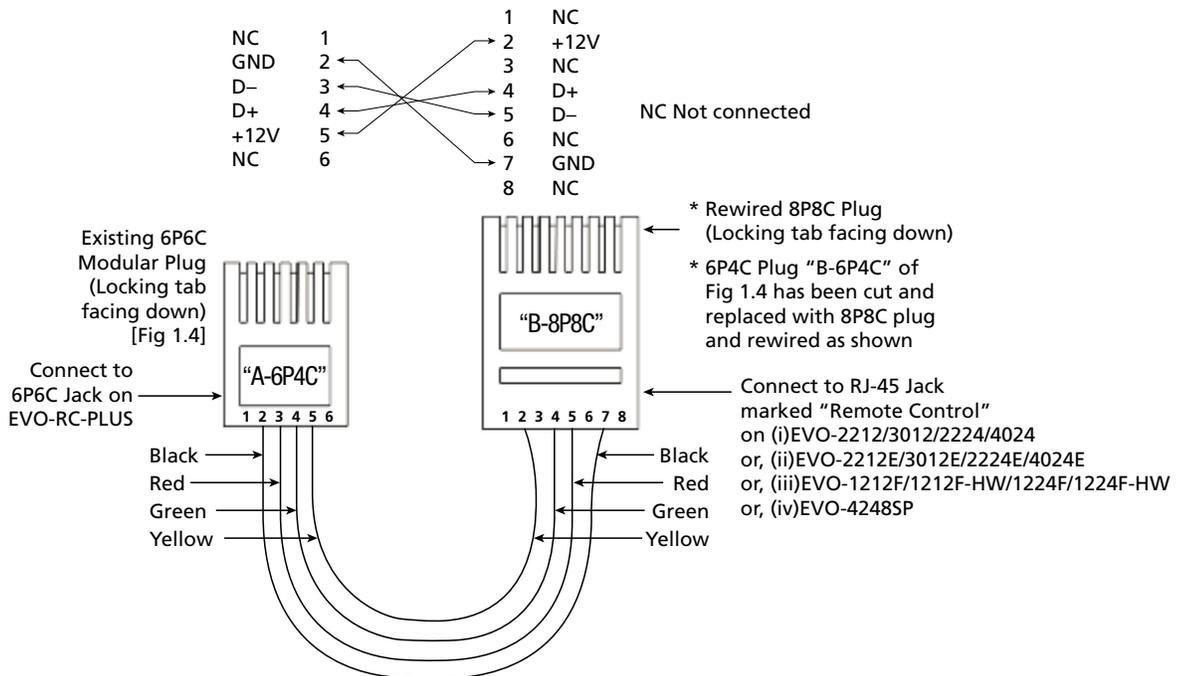

Fig 1.5 RJ-11 (6P4C) cable (Fig 1.4) rewired on one end with RJ-45 (8P8C) Modular Plug

SECTION 2 | Installation

2.0 INSTALLATION GUIDELINES

EVO-RC-PLUS is provided with 10M/33ft, RJ-45 data cable (*straight wired*). Check the proposed routing distance of the wire and use longer wire, if necessary.

- Flush mounting of the Remote requires appropriate cut-out in the wall/panel - See Fig 2.1.
- Full scale installation Template for panel cut-out and pilot holes for mounting screws is also provided along with the unit. Take necessary precautions to ensure any wiring/plumbing running behind the wall/panel is not damaged.
- Route the wire to ensure there are no kinks.
- Use appropriate grommets when the wire is passed through holes in studs/partitions to prevent damage to insulation.

2.1 TOOLS REQUIRED

Following tools are recommended:

- Phillips head screwdriver
- Level
- Hand Drill
- Knife/Saw
- Pencil
- Drill Bit (2mm / 5/64")

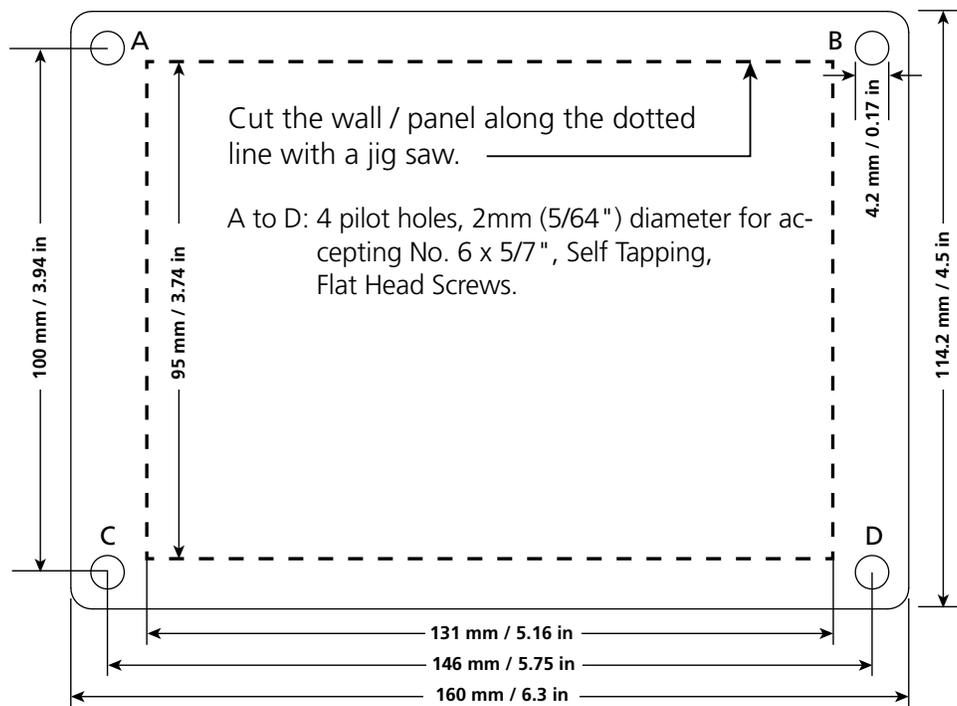

Fig 2.1 EVO-RC-PLUS Remote installation details

2.2 FLUSH MOUNT INSTALLATION

To flush mount, the wall opening must have at least 2" (5 cm) depth to make room for the remote and cable. Also, the thickness of wall/panel board at the place of mounting should not be more than 13 mm to ensure that the RJ-45 / RJ-12 Jack openings are not obstructed (*see Fig. 2.3*).

SECTION 2 | Installation

1. Cut an opening in the wall using the supplied Installation Template (*based on Fig 2.1*).
2. Drill four pilot holes (*use 2mm / 5/64" diameter drill bit*) for 4 screw (*Self Taping, Flat Head No. 6 x 5/8" long*) that will attach the remote to the wall (*refer to Fig. 2.1 for hole locations and dimensions*).
3. Route one end of the cable through wall opening to the EVO™ Inverter/Charger, and then plug it into the RJ-45 Remote Control Jack port on the EVO™ Inverter/Charger
4. Take the other end of the remote cable and plug it into the RJ-45 / RJ-12 Jack at the back of the EVO-RC-PLUS (*Fig. 2.3*).
5. Check the remote display to ensure the Power-up Self Test initiates.
6. If the self test is successful, secure the EVO-RC-PLUS to the wall using the four screws (*Fig. 2.2*).

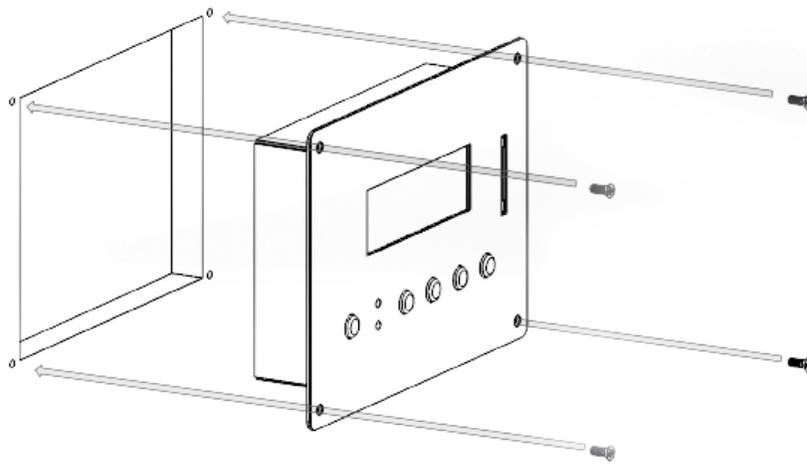

Flush mounting the EVO-RC-PLUS on the wall with 4 screws:
No. 6 x 5/8", Self Tapping, Flat Head.

Fig 2.2 EVO-RC-plus Flush Mounting

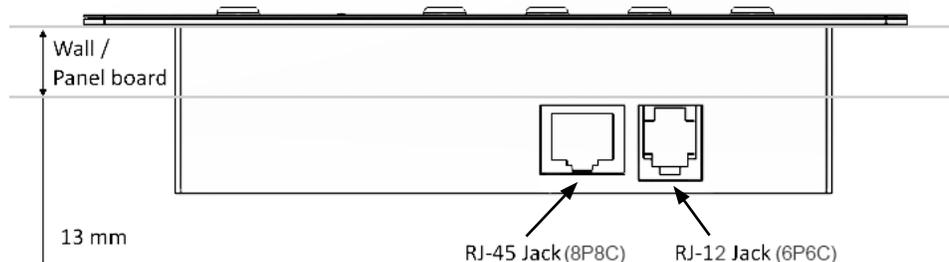

The thickness of the wall/panel board at the place of mounting should not be more than 13 mm to ensure that the RJ-45 / RJ-12 jack openings are not obstructed.

Fig 2.3 Wall/Panel Thickness

SECTION 3 | Operation

3.0 GENERAL INFORMATION

EVO-RC-PLUS Remote Control provides the user with the ability to monitor the operation and also to modify EVO™ Inverter/Charger's operating parameters. The default settings in EVO™ Inverter/Charger are adequate for some installations but may have to be modified for others. This Section provides details on the remote functions, status and menu maps and displays, fault messages and parameter settings.

3.1 NAVIGATING THE REMOTE

Please refer to the layout at Fig. 1.1.

- **LCD Display (1)** – The 4-line (20 characters each) LCD display shows status and information for the EVO™ Inverter/Charger. All Setup Menus and faults also appear on the LCD display.
The level of brightness / dimming of the LCD backlight can be programmed to suit user preference. (*See Section 4.9 for details*)
- **ON/OFF Key (2)** – The On/Off Key is used for switching on/ switching off the EVO™ Inverter/Charger and also to enter/exit Standby Mode.
- **Navigation Keys (5, 6, 7, 8)** – These four keys allow simple access to Menu Item that assists configuring, monitoring, and troubleshooting the EVO™ Inverter/Charger.
 - **Navigation Key Functions:**
 - **Back** – Return to previous selection
 - **Up** – Scroll from lower to upper Menu Screen in various Menu Maps e.g. Fig 3.1 (a)
 - **Down** – Scroll from upper to lower Menu Screen in various Menu Maps e.g. Fig 3.1(a)
 - **Enter** – Select/write a particular value or option.
- **Status** – Blue LED indicator for indicating operating status (*see details at Section 6, Table 6.1*).
- **Fault** – Red LED indicator for indicating fault conditions (*see details at Section 6, Table 6.1*).
- **SD Card slot** – This slot supports SD memory card (*up to 32GB, FAT16/32*). The SD Card is used for data logging of EVO™ Inverter/Charger's operational statistics and events and saving and uploading of programmed parameters. See Section 5: SD Card.

SECTION 3 | Operation

3.2 POWER ON / POWER OFF



INFO

- a) Minimum battery voltage required for initiating ***MANUAL powering ON*** of EVO™ Series Inverter/Chargers is given below:
- 12V Models: → *Higher than 9V*
 - 24V Models: → *Higher than 18V*
 - 48V Models: → *Higher than 36V*
- b) EVO™ Series Inverter/Chargers ***will power ON automatically*** when the battery voltage and AC input voltage are within the limits shown in the Table given below:

Model No.	Battery Voltage Limit to Power ON Automatically	AC Input Voltage Limit to Power ON Automatically	
EVO-1212F/EVO-1212F-HW/ EVO-2212/ /EVO-3012	>12 VDC	> 70 ± 5 VAC	
EVO-1224F/ EVO-1224F-HW/ EVO-2224/EVO-4024	>24 VDC		
EVO-2212E/EVO-3012E	>12 VDC	> 140 ± 10 VAC	
EVO-2224E/EVO-4024E	>24 VDC		
EVO-4248SP	>36 VDC	<u>Line Voltage</u> > 170 VAC ± 5%	<u>Phase Voltage</u> > 85 VAC ± 5%

If the AC input voltage and frequency are within the programmed limits, the units will power ON automatically and will start operating in “Charging Mode”. If the AC input voltage and frequency are not within the programmed limits, the units will power ON automatically and will start operating in “Inverting Mode”

- c) To power OFF the EVO™ Inverter/Chargers manually using the ON/OFF Button on the front panel of the unit or the ON/OFF Key on the Remote-Control EVO-RC-PLUS, there should be no AC input voltage or, has to be less than the limits shown in the Table below. ***First, Switch OFF the AC input power to the unit and then, POWER OFF manually.*** However, if a unit is in “Fault Mode” (***Fault messages in Table 7.1, Section 7***), it will be possible to power OFF the unit manually with the help of ON/OFF Button on the front panel of the unit or the ON/OFF Key on the Remote-Control EVO-RC-PLUS

Model No.	AC Input Voltage Limit to Power ON Automatically	
EVO-1212F/EVO-1212F-HW/ EVO-2212/ /EVO-3012	< 70 ± 5 VAC	
EVO-1224F/ EVO-1224F-HW/ EVO-2224/EVO-4024		
EVO-2212E/EVO-3012E	< 140 ± 10 VAC	
EVO-2224E/EVO-4024E		
EVO-4248SP	<u>Line Voltage</u> < 140 VAC ± 3%	<u>Phase Voltage</u> < 70 VAC ± 3%

SECTION 3 | Operation

3.3 DATE AND TIME SETUP

Set date and time as per procedure given at Section 4.10: "Group 7 Parameter Setup: Time Setting".

3.4 STANDBY MODE

When the EVO™ is in Standby Mode, inverting or charging / AC pass through will be suspended.



Standby Mode may be used to temporarily halt normal operation of the Inverter/Charger without switching OFF the unit completely.

For the Standby Mode to be switched ON, the EVO™ should be in ON condition, and displaying one of the active Operating Mode screens from the associated Menu Maps detailed in Table 3.1 under Section 3.6.1. When Standby Mode is switched ON, the EVO™ will suspend its Operating Mode.

Standby Mode is toggled between ON and OFF conditions as detailed at Section 3.4.1.

3.4.1 Procedure to Enter and Exit Standby Mode / Status Display in Standby Mode



- EVO-RC-PLUS Remote Control will be required to be connected to the EVO™ Inverter/Charger Unit to enter Standby Mode as explained at Section 3.4.1.1 below. Once Standby Mode has been entered using EVO-RC-PLUS Remote Control, it can **ALSO** be switched off using the On/Off Push Button on the front panel of the EVO™ Inverter/Charger Unit (*See Section 3.4.1.2*)
- If EVO-RC-PLUS Remote Control has **NOT** been connected to the EVO™ Inverter/Charger Unit, Standby Mode cannot be entered using the On/Off Push Button on the front panel of the EVO™ Inverter/Charger Unit

3.4.1.1 Entering Standby Mode Using Remote Control EVO-RC-PLUS: Changing over from any Operating Mode (*"Inverting", "Charging", "Power Save" etc.*) to Standby Mode can be carried out with the help of Remote-Control EVO-RC-PLUS as follows:

- a) From any Operating Mode Screen (*"Inverting", "Charging", "Power Save" etc.*), press the On/Off Key (*2, Fig 1.1*) momentarily (*0.1 sec*)
- b) Screen shown below will be displayed for 5 sec **and then, the screen will go back to the Operating Mode Screen.**

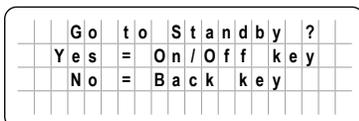

- If Standby Mode is required to be activated, press the On/Off Key (*2, Fig 1.1*) momentarily (*0.1 sec*)
 - If Standby Mode is not required to be activated, press the Back Key (*5, Fig 1.1*) momentarily (*0.1 sec*)
- c) On entering Standby Mode, the following will be displayed:

SECTION 3 | Operation

i. On the EVO-RC-PLUS:

a. For EVO-1212F/1212F-HW/1224F/1224F-HW:

- The LCD will show the 1st Screen (Screen 1) of the 7 Standby Mode Screens [See Fig 3.1(a)]

EVO-1212F	Standby
AC output:	0.0V
	<0.1A
	0.00Hz

- Blue LED marked "Status" (3, Fig 1.1) will blink once every 5 sec

b. For (i) EVO-2212/3012/2224/4024 and (ii) : EVO-2212E/3012E/2224E/4024E

- The LCD will show the 1st screen (Screen 1) of the 9 Standby Mode Screens for (i) EVO-2212/3012/2224/4024 and (ii) EVO-2212E/3012E/2224E/4024E [see at Fig 3.1(b)]

EVO-3012	Standby
AC output:	0.0V
	<0.1A
	0.00Hz

c. For EVO-4248SP:

- The LCD will show the 1st screen (Screen 1) of the 7 Standby Mode Screens for EVO-4248SP [See Fig 3.1(c)]

EVO-4248SP	Standby
AC output:	0.0V
	0.0Hz
	<0.15A
	<0.15A

- Blue LED marked "Status" (3, Fig 1.1) will blink once every 5 sec

ii. On the Front Panel of EVO™ Inverter/Charger: The Blue LED marked "ON" (12, Fig 2.1 of the EVO™ Inverter/Charger Manual) will blink once every 5 sec. Red LED marked "FAULT" (13, Fig 2.1 of EVO™ Inverter/Charger Manual) and Buzzer will be off

3.4.1.2 Exiting Standby Mode:

- Using EVO-RC-PLUS: To exit Standby Mode using EVO-RC-PLUS, press the On/Off Key (2, Fig 1.1) momentarily (0.1 sec).
- From Front Panel of EVO™ Inverter/Charger Unit: To exit Standby Mode from the EVO™ unit, momentarily (0.1 sec) press the On/Off Push Button on the front panel of the EVO™ (11, Fig 2.1 of the EVO™ Inverter/Charger Manual)



INFO

Please note that when Standby Mode is exited, EVO™ Inverter/Charger Unit will execute the programmed Operating Mode from the beginning. It will **NOT** start from the last condition of the operating stage it was in when Standby Mode was activated

3.5. FAULT MESSAGES & CLEARING FAULTS

If any fault occurs, the LCD screen will display the Fault Message and the Red LED "Fault" (4, Fig 1.1) will be lighted. Refer to Table 7.1 at Section 7 for details of various fault messages and procedure to clear the fault.

SECTION 3 | Operation



CAUTION!

The cause of the fault should be removed before the unit is restarted.



ATTENTION!

La cause du défaut doit être éliminée avant le redémarrage de l'unité.

3.6 OPERATING MODES AND ASSOCIATED LCD DISPLAY SCREENS

3.6.1 General Information

When the unit is operating normally, the LCD Screen will display the name of the Operating Mode (*See Column 1 of Table 3.1*) and values of various associated operating parameters. As all the operating parameters associated with a particular Operating Mode cannot be displayed in one screen, multiple screens are available that can be accessed by scrolling the Up and Down Keys. For ease of navigating through the various screens, all the screens covering a particular Operating Mode have been arranged in a Menu Map – for example, see Menu Map for Inverting Mode at Figs 3.2(a), 3.2(b) and 3.2(c). Table 3.1 shows the names of the Operating Modes and the Fig Nos. of the associated Menu Maps.

Typical Operating Mode Display Screen is shown in Fig 3.0 [*Example of Screen 1 of Inverting Mode Menu Map at Fig 3.2(a)*]. There are 4 lines of display (*up to 20 characters per line*). The 1st line shows the Model No on the left side and the Operating Mode on the right side. The 2nd, 3rd and the 4th lines display various operating parameters and their values.

E	V	O	-	1	2	1	2	F		I	n	v	e	r	t	i	n	g	
A	C																		

Fig 3.0 Typical Operating Mode Display Screen
(*Screen No. 1 of Inverting Mode Menu Map at Fig 3.2(a) for EVO-1212F / EVO-1212F-HW / EVO-1224F / EVO-1224F-HW*)

SECTION 3 | Operation

Table 3.1 Operating Modes and Associated Menu Maps/ LCD Display Screens				
Operating Mode Display	Description	Operating Mode Screen Menu Map		
		Models EVO-1212F / 1212F HW / 1224F / 1224F-HW	Models (i) EVO-2212 / 3012 / 2224 / 4024 and (ii) EVO-2212E / 3012E / 2224E / 4024E	Model EVO-4248SP
(Column 1)	(Column 2)	(Column 3)	(Column 4)	(Column 5)
Standby	Standby Mode: No output, No AC bypass, No Charging	Fig 3.1(a), Section 3.6.2.1	Fig 3.1(b), Section 3.6.2.2	Fig 3.1(c), Section 3.6.2.3
Inverting	Unit is operating as an inverter	Fig 3.2(a), Section 3.6.3.1	Fig 3.2(b), Section 3.6.3.2	Fig 3.2(c), Section 3.6.3.3
Charging	Unit is operating as a battery charger and passing through the AC input to the loads	Fig 3.3(a), Section 3.6.4.1	Fig 3.3(b), Section 3.6.4.2	Fig 3.3(c), Section 3.6.4.3
PowerSave	Unit is in Power Saving Mode	Fig 3.4(a), Section 3.6.5.1	Fig 3.4(a), Section 3.6.5.2	Fig 3.4(c), Section 3.6.5.3
Online	Unit is in On Line Mode	Figs 3.5(a) to 3.5(d), Section 3.6.6		
Chrg Only	Under "ONLINE MODE" only (Option 2=Charger Only). Provides charging and pass through when the AC input is available. No inverting when the AC input is not available.	Fig 3.6(a), Section 3.6.7.1	Fig 3.6(b), Section 3.6.7.2	Fig 3.6(c), Section 3.6.7.3
Charger Stop by BMS	Applicable when BATTERY TYPE Option 1=Lithium is selected. This mode is activated when the Lithium Battery Management System (BMS) sends command to EVO™ (contact closure signal) to stop charging to prevent battery over voltage or over temperature.	Fig 3.7(a), Section 3.6.8.1	Fig 3.7(b), Section 3.6.8.2	Fig 3.7(c), Section 3.6.8.3
Inverter stop by BMS	Applicable when BATTERY TYPE Option 1=Lithium is selected. This mode is activated when the Lithium Battery Management System (BMS) sends command to EVO™ (contact closure signal) to stop inverting to prevent deep discharge of the battery.	Fig 3.8(a), Section 3.6.9.1	Fig 3.8(b), Section 3.6.9.2	Fig 3.8(c), Section 3.6.9.3

3.6.2 Menu Map for Standby Mode Screens

Menu Maps for the Operating Mode Screens for the Standby Mode are shown as follows:

- Section 3.6.2.1: Fig 3.1(a) for Models EVO-1212F / 1212F-HW / 1224F / 1224F-HW
(Model No. shown in the screens is EVO-1212F)
- Section 3.6.2.2: Fig 3.1(b) for (i) Models EVO-2212 / 3012 / 2224 / 4024 and (ii) Models EVO-2212E / 3012E / 2224E / 4024E
(Model No. shown in the screens is EVO-3012)
- Section 3.6.2.3: Fig 3.1(c) for Model EVO-4248SP

SECTION 3 | Operation

3.6.2.1 Menu Map for Standby Mode Screens for Models EVO-1212F / 1212F-HW / 1224F / 1224F-HW

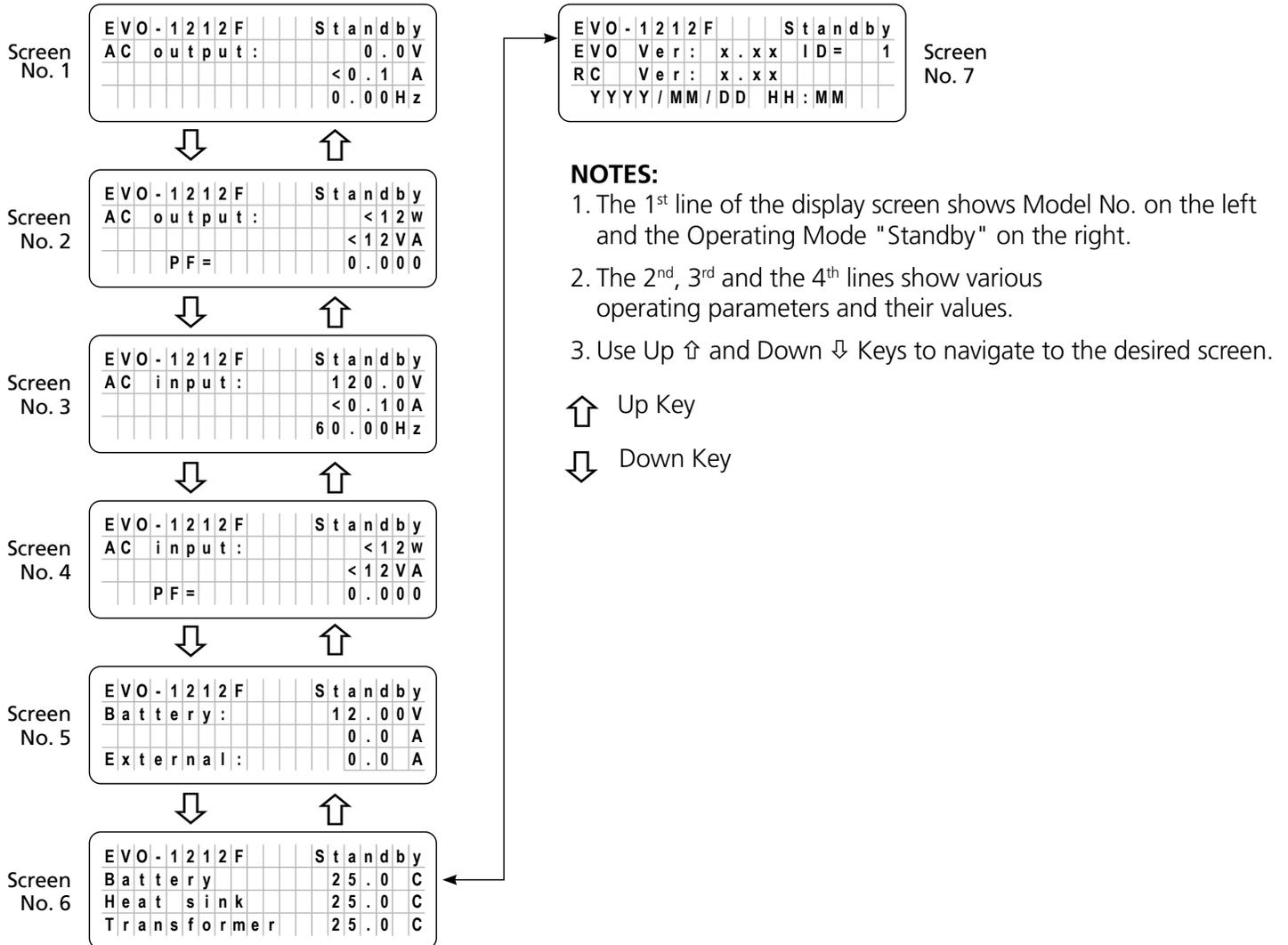

Fig 3.1(a) Menu Map for Standby Mode Screens for Models EVO-1212F / EVO-1212F-HW / 1224F / 1224F-HW (Model No. shown is EVO-1212F)

SECTION 3 | Operation

3.6.2.2 Menu Map for Standby Mode Screens for Models (i) EVO-2212 / 3012 / 2224 / 4024 and (ii) EVO-2212E / 3012E / 2224E / 4024E

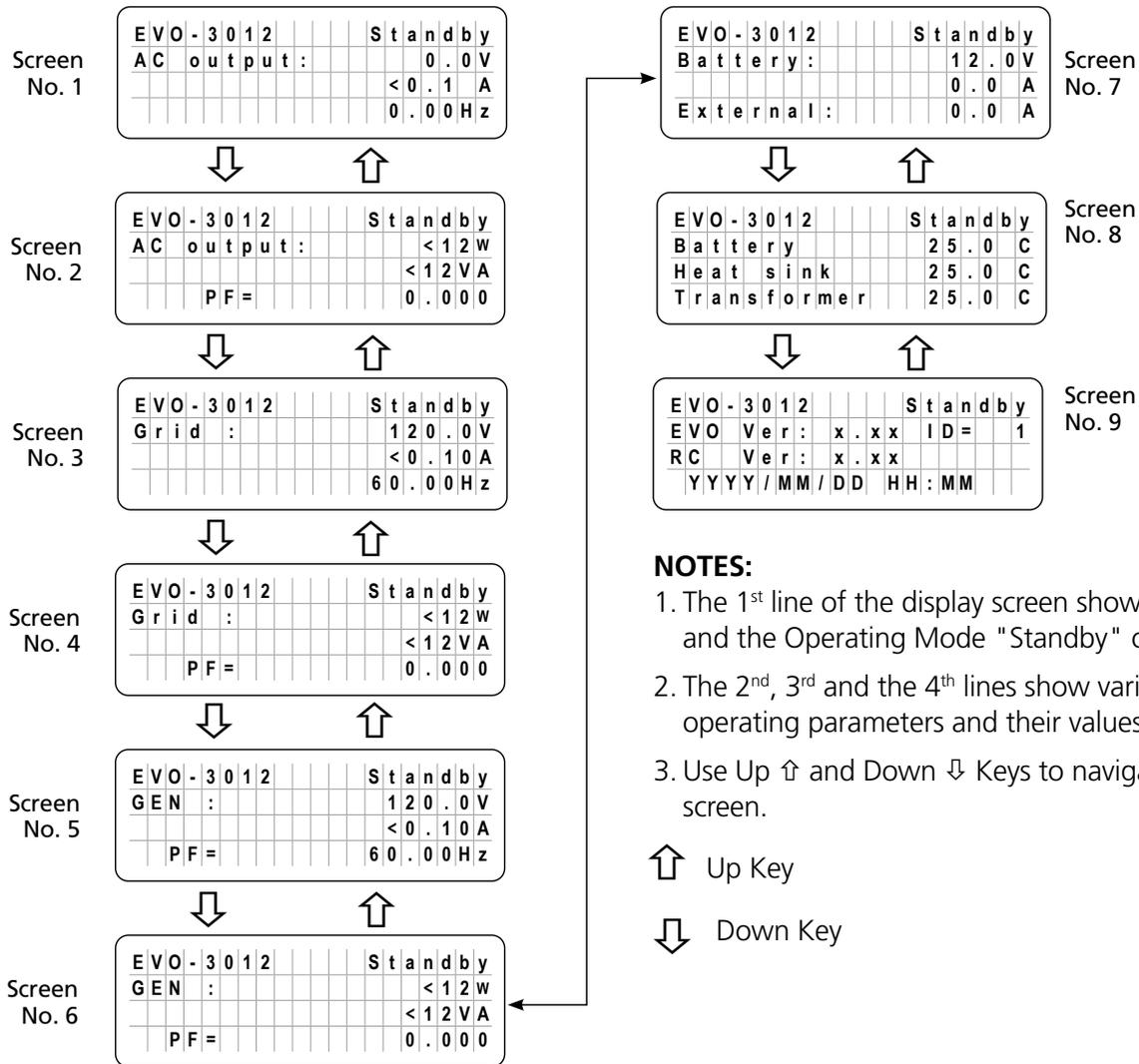

Fig 3.1(b) Menu Map for Standby Mode Screens for Models (i) EVO-2212 / 3012 / 2224 / 4024 and (ii) EVO-2212E / 3012E / 2224E / 4024E
(Model No. shown is EVO-3012)

SECTION 3 | Operation

3.6.2.3 Menu Map for Standby Mode Screens for Model EVO-4248SP

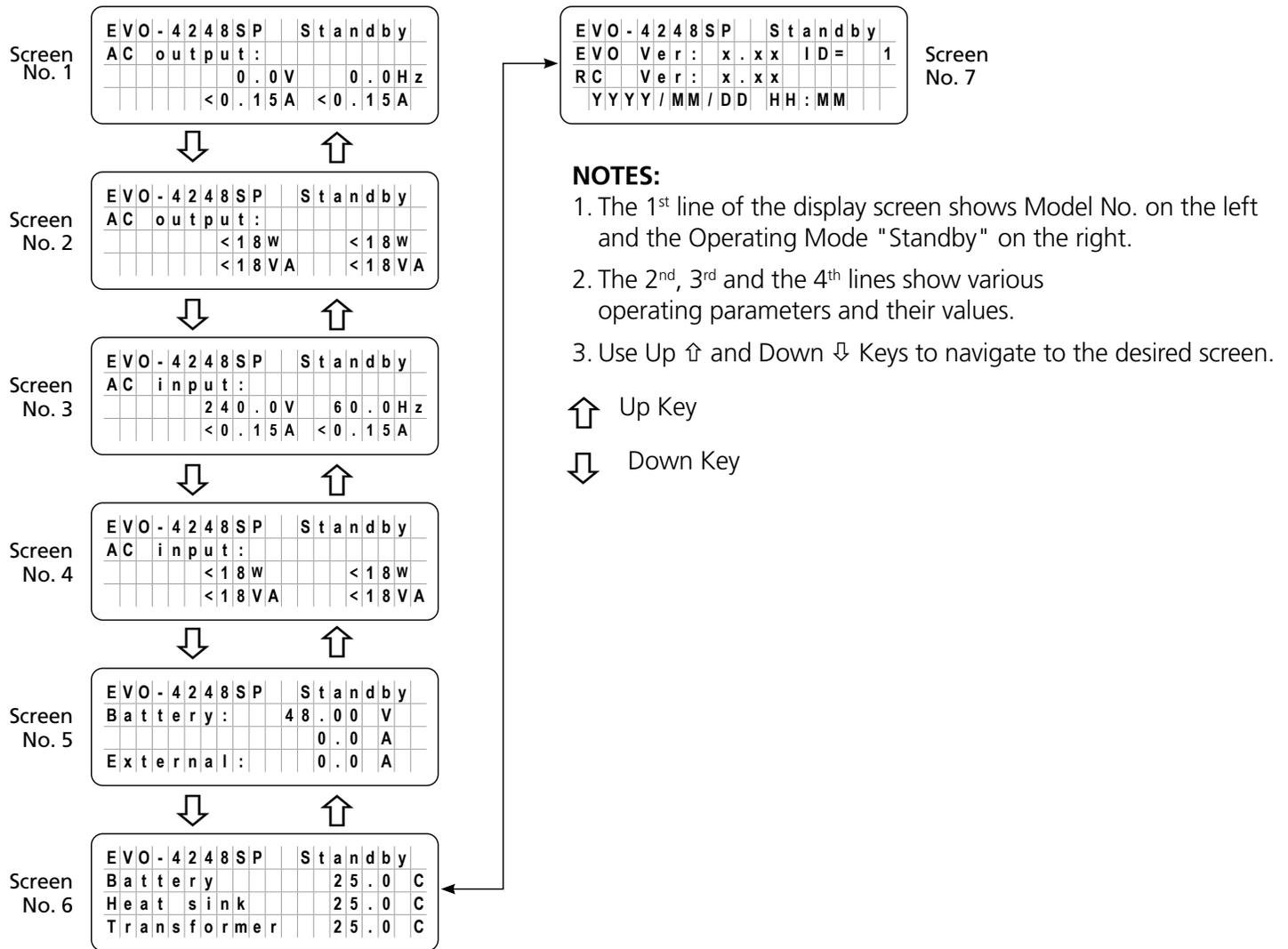

Fig 3.1(c) Menu Map for Standby Mode Screens for Model EVO-4248SP

SECTION 3 | Operation

3.6.3 Menu Map for Inverting Mode Screens

Menu Maps for the Operating Mode Screens for the "Inverting" Mode are shown as follows:

- Section 3.6.3.1: Fig 3.2(a) for Models EVO-1212F / 1212F-HW / 1224F / 1224F-HW
(Model No. shown in the screens is EVO-1212F)
- Section 3.6.3.2: Fig 3.2(b) for Models (i) EVO-2212 / 3012 / 2224 / 4024 and (ii) EVO-2212E / 3012E / 2224E / 4024E
(Model No. shown in the screens is EVO-3012)
- Section 3.6.3.3: Fig 3.2(c) for Model EVO-4248SP

3.6.3.1 Menu Map for Inverting Mode Screens for Models EVO-1212F / 1212F-HW / 1224F / 1224F-HW

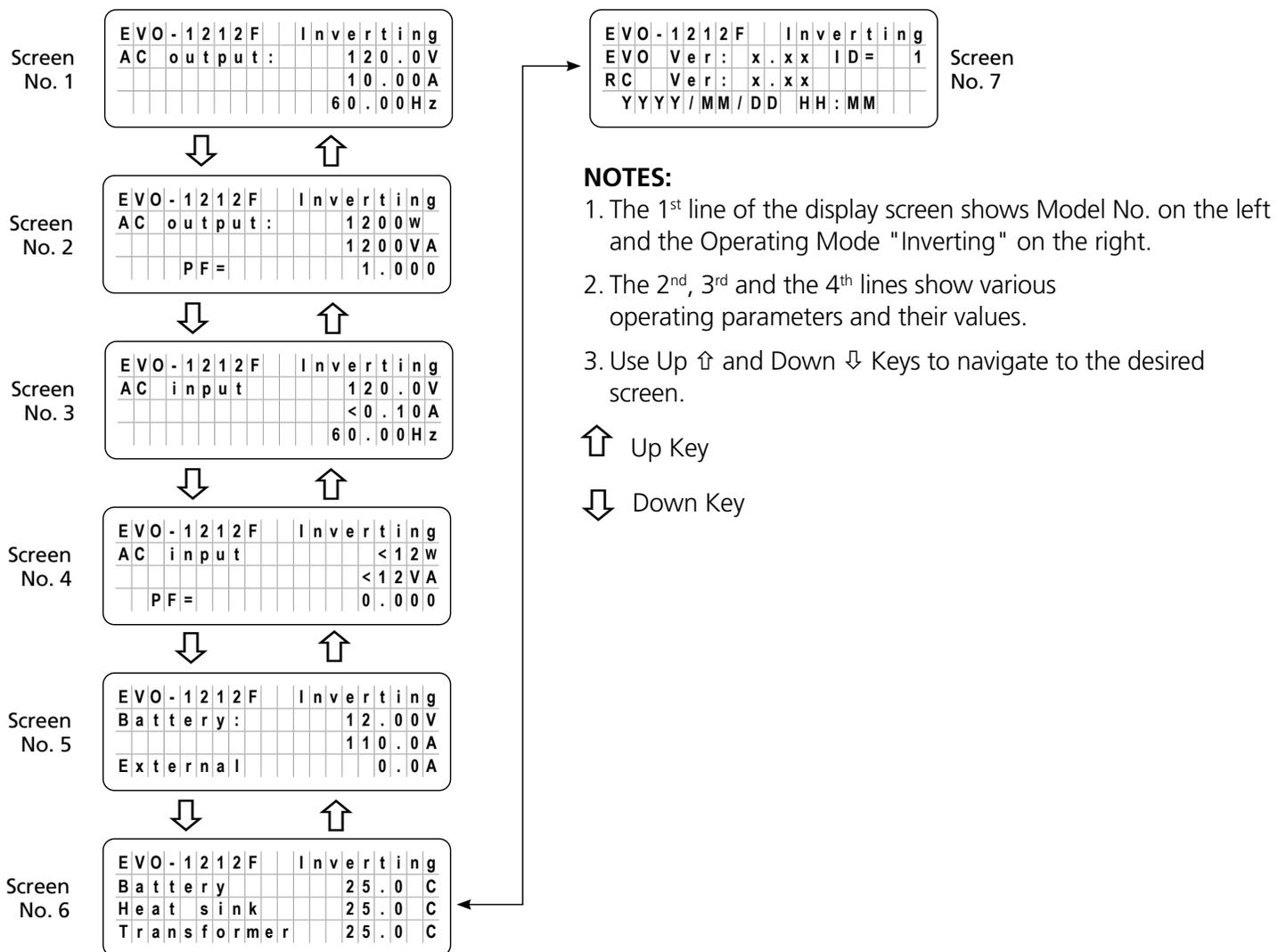
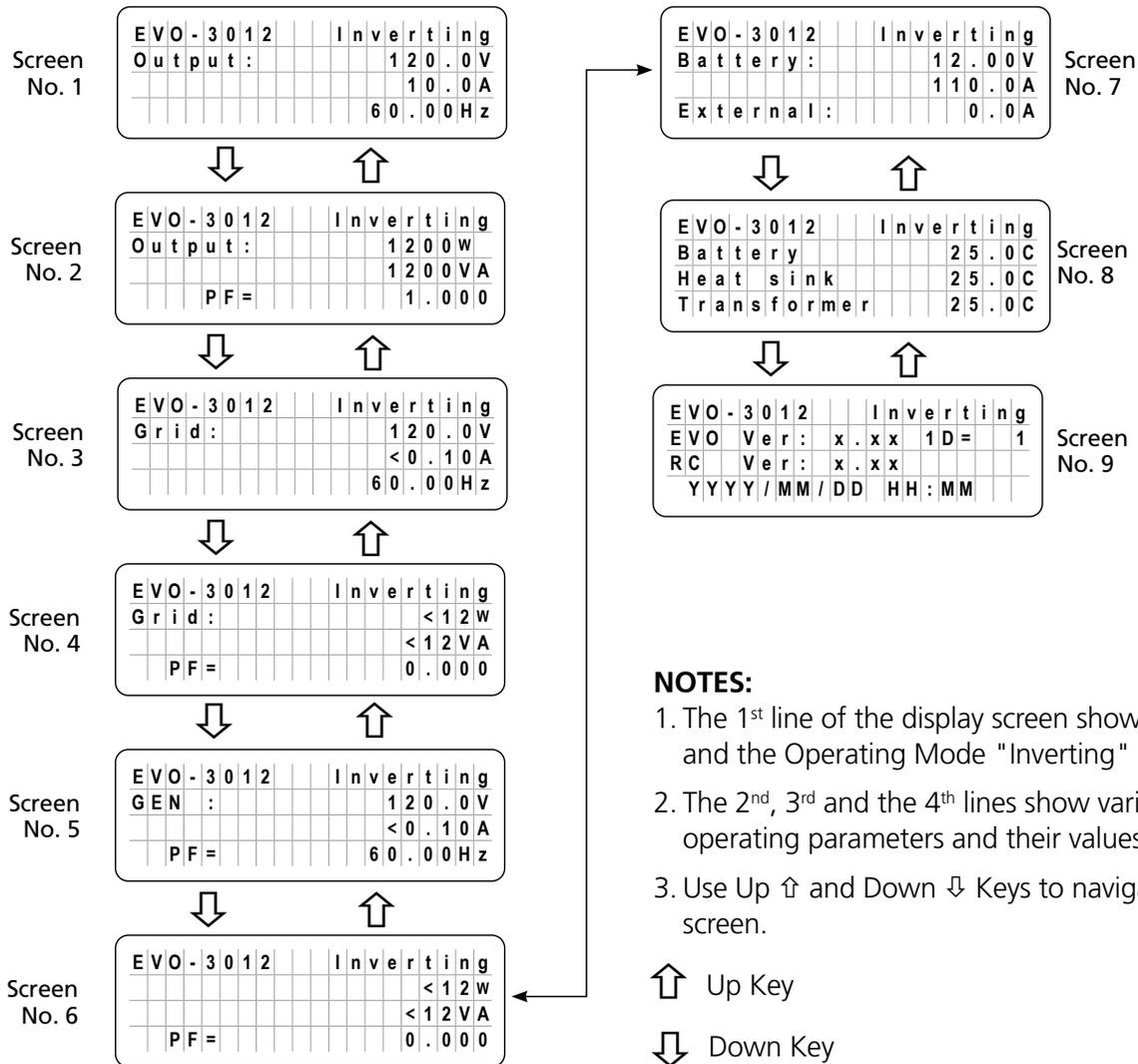

Fig 3.2(a) Menu Map for Inverting Mode Screens for Models EVO-1212F / 1212F-HW / 1224F / 1224F-HW (Model No. Shown is EVO-1212F)

SECTION 3 | Operation

3.6.3.2 Menu Map for Inverting Mode Screens for Models (i) EVO-2212 / 3012 / 2224 / 4024 and (ii) EVO-2212E / 3012E / 2224E / 4024E



NOTES:

1. The 1st line of the display screen shows Model No. on the left and the Operating Mode "Inverting" on the right.
2. The 2nd, 3rd and the 4th lines show various operating parameters and their values.
3. Use Up ↑ and Down ↓ Keys to navigate to the desired screen.

↑ Up Key

↓ Down Key

Fig 3.2(b) Menu Map for Inverting Mode Screens for Models (i) EVO-2212 / 3012 / 2224 / 4024 and (ii) EVO-2212E / 3012E / 2224E / 4024E
(Model No. shown is EVO-3012)

SECTION 3 | Operation

3.6.3.3 Menu Map for Inverting Mode Screens for Model EVO-4248SP

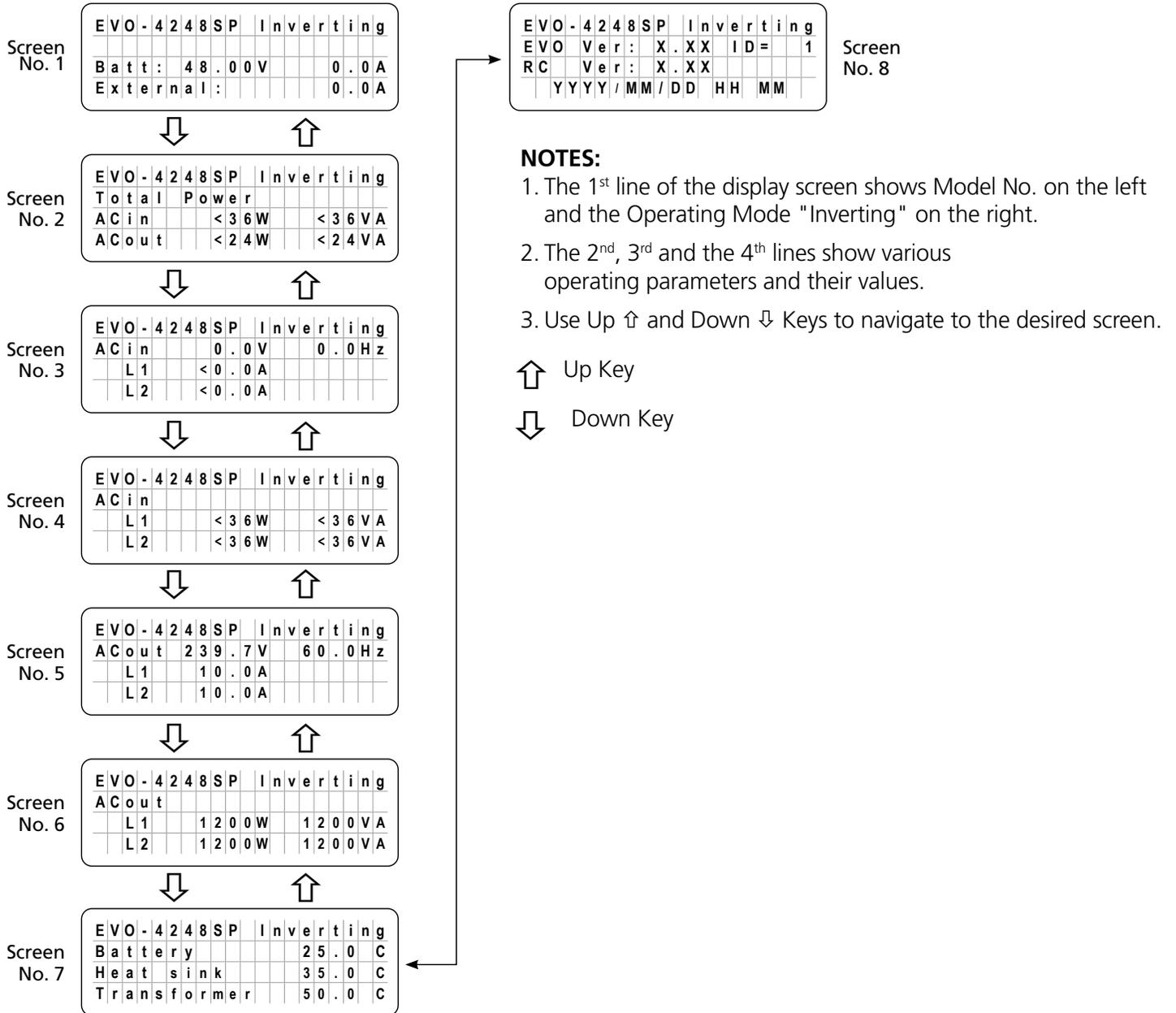

Fig 3.2(c) Menu Map for Inverting Mode Screens for Model EVO-4248SP

SECTION 3 | Operation

3.6.4 Menu Map for Charging Mode Screens

Menu Maps for the Operating Mode Screens for the "Charging" Mode are shown as follows:

- Section 3.6.4.1: Fig 3.3(a) for Models EVO-1212F / 1212F-HW / 1224F / 1224F-HW (*Model No. shown in the screens is EVO-1212F*)
- Section 3.6.4.2: Fig 3.3(b) for Models (i) EVO-2212 / 3012 / 2224 / 4024 and (ii) EVO-2212E / 3012E / 2224E / 4024E (*Model No. shown in the screens is EVO-3012*)
- Section 3.6.3.3: Fig 3.3(C) for Model EVO-4248SP

3.6.4.1 Menu Map for Charging Mode Screens for EVO-1212F / 1212F-HW / 1224F / 1224F-HW

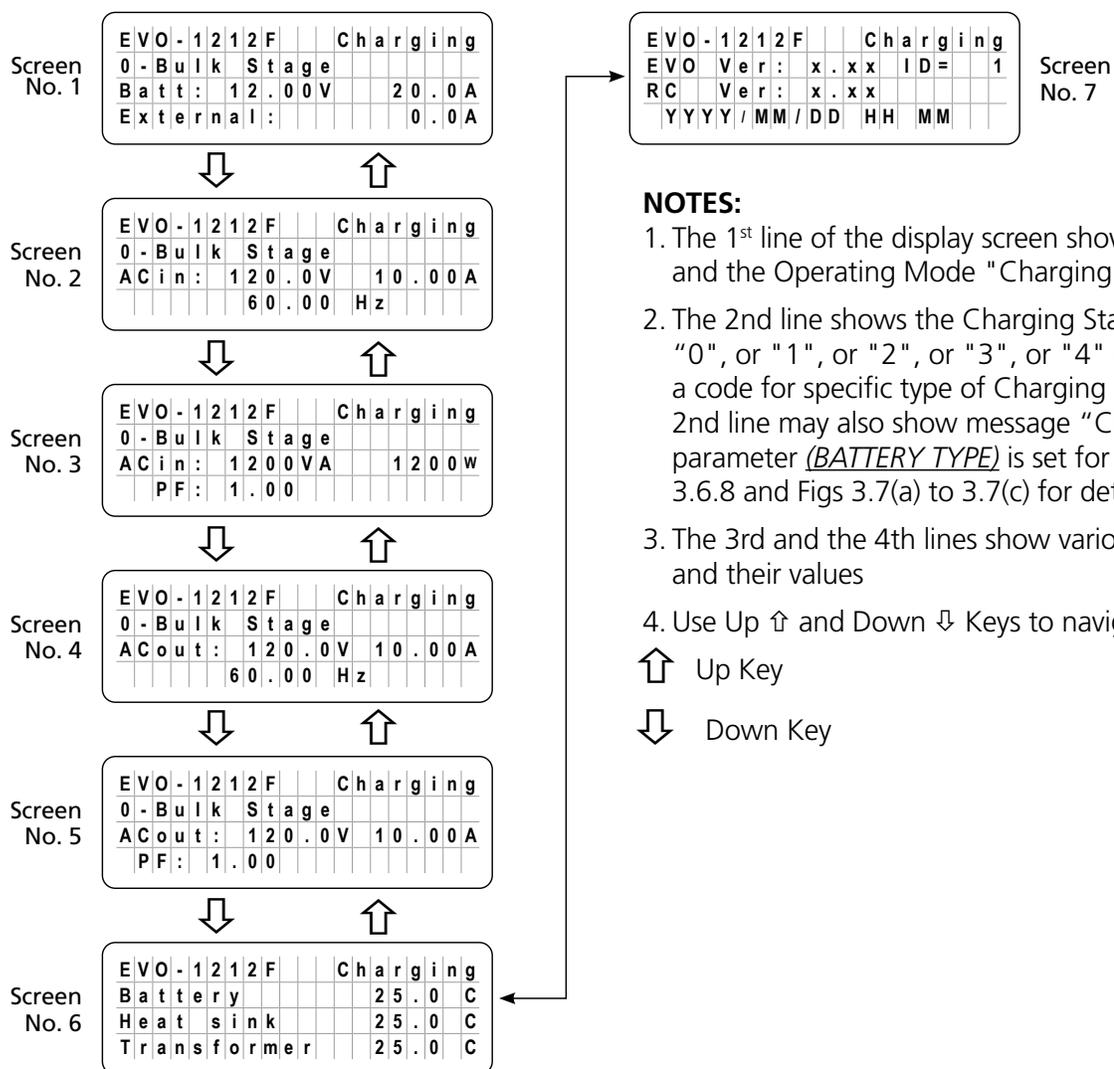

Fig 3.3(a) Menu Map for Charging Mode Screens for Models EVO-1212F / EVO-1212F-HW / 1224F / 1224F-HW (*Model No. shown is EVO-1212F*)

SECTION 3 | Operation

3.6.4.2 Menu Map for Charging Mode Screens for Models (i) EVO-2212 / 3012 / 2224 / 4024 and (ii) EVO-2212E / 3012E / 2224E / 4024E

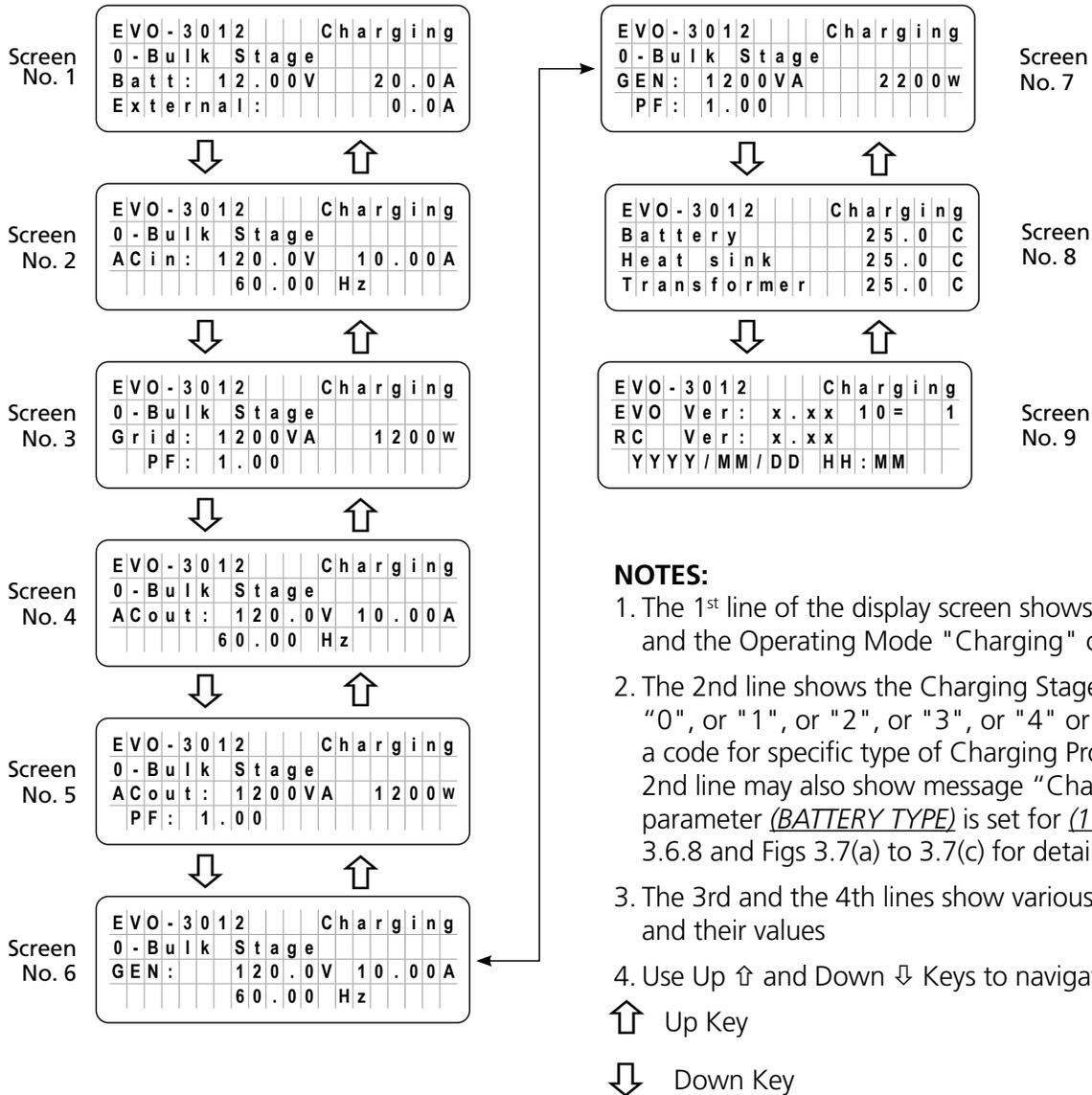

Fig 3.3(b) Menu Map for Charging Mode Screens for Models (i) EVO-2212 / 3012 / 2224 / 4024 and (ii) EVO-2212E / 3012E / 2224E / 4024E
(Model No. shown is EVO-3012)

SECTION 3 | Operation

3.6.4.3 Menu Map for Charging Mode Screens for Model EVO-4248SP

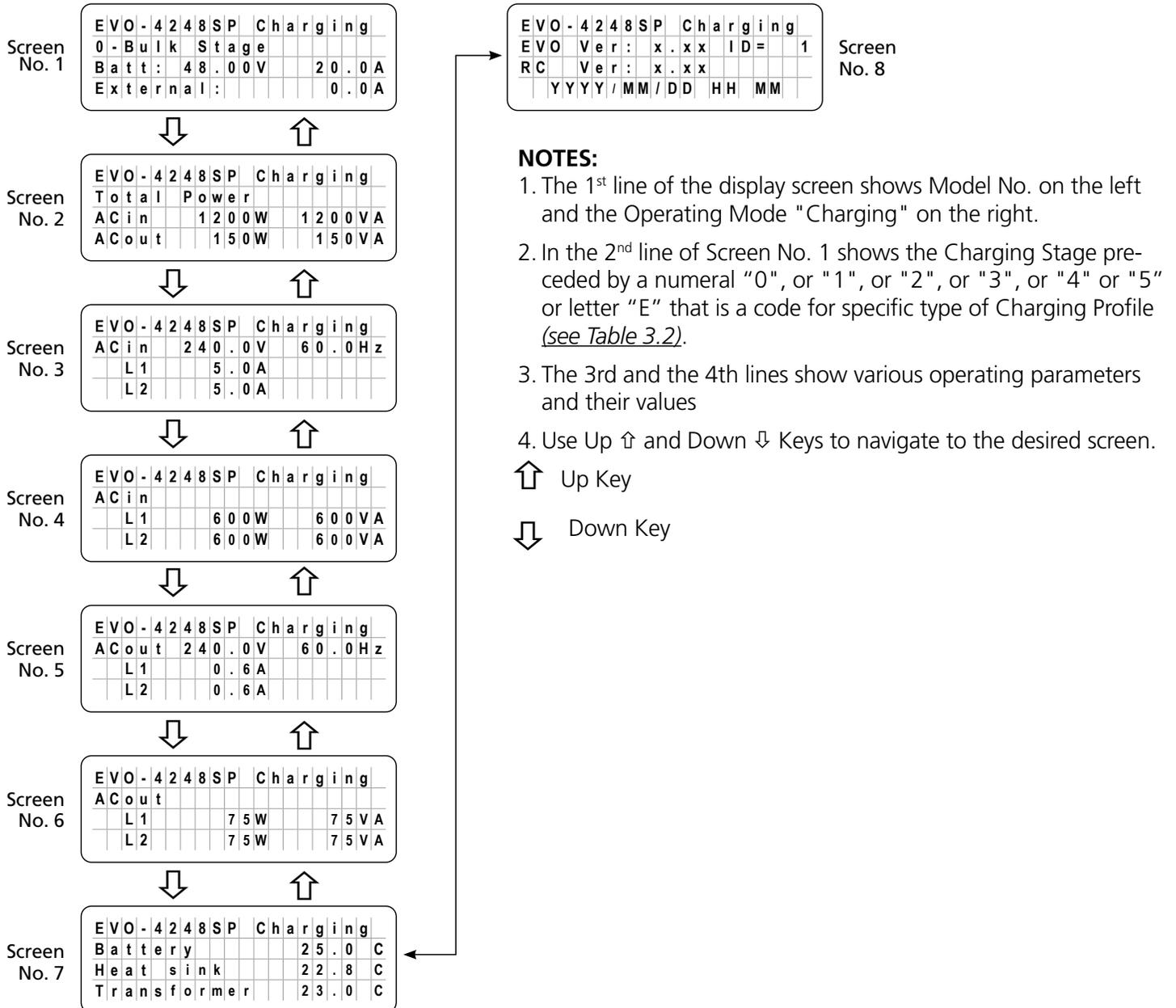

Fig 3.3(c) Menu Map for Charging Mode Screens for Model EVO-4248SP

SECTION 3 | Operation

3.6.4.4 Details of Charging Profiles in Charging Mode Screens

Refer to the 2nd Line of the following Charging Mode Screens:

- Fig 3.3(a) under Section 3.6.4.1 for Models EVO-1212F / 1212F-HW / 1224F / 1224F-HW
- Fig 3.3(b) under Section 3.6.4.2 for Models (i) EVO-2212 / 3012 / 2224 / 4024 and (ii) EVO-2212E / 3012E / 2224E / 4024E
- Fig 3.3(c) under Section 3.6.4.3 for Model EVO-4248SP

Details of information related to this line on the screen are shown in Table 3.2.

Table 3.2 Details of Charging Stages & Profiles Indicated in 2nd Line of Charging Mode Screens	
2nd Line of Screens in Fig 3.3(a), 3.3(b) & 3.3(c)	Description
0- Bulk Stage	Constant Current, Bulk Stage. <i>[Parameter "CHARGING PROFILE" option: "0 = 3 Stage Adaptive"]</i>
1- Bulk Stage	Constant Current, Bulk Stage. <i>[Parameter "CHARGING PROFILE" option: "1 = 3 Stage Type 1"]</i>
2- Bulk Stage	Constant Current, Bulk Stage. <i>[Parameter "CHARGING PROFILE" option: "2 = 3 Stage Type 2"]</i>
3- Bulk Stage	Constant Current, Bulk Stage. <i>[Parameter "CHARGING PROFILE" option: "3 = 2 Stage Type 1"]</i>
4- Bulk Stage	Constant Current, Bulk Stage. <i>[Parameter "CHARGING PROFILE" option: "4 = 2 Stage Type 2"]</i>
5- Bulk Stage	Constant Current, Bulk Stage. <i>[Parameter "CHARGING PROFILE" option: "5 = 2 Stage Type 3"]</i>
E- Bulk Stage	Constant Current, Bulk Stage. <i>[Parameter "EQUALIZE-4STAGES" option: "1=Yes"]</i>
0- Absorption Stage	Constant Voltage, Absorption Stage. <i>[Parameter "CHARGING PROFILE" option: "0 = 3 Stage Adaptive"]</i>
1- Absorption Stage	Constant Voltage, Absorption Stage. <i>[Parameter "CHARGING PROFILE" option: "1= 3 Stage Type 1"]</i>
2- Absorption Stage	Constant Voltage, Absorption Stage. <i>[Parameter "CHARGING PROFILE" option: "2 = 3 Stage Type 2"]</i>
3- Absorption Stage	Constant Voltage, Absorption Stage. <i>[Parameter "CHARGING PROFILE" option: "3= 2 Stage Type 1"]</i>
4- Absorption Stage	Constant Voltage, Absorption Stage. <i>[Parameter "CHARGING PROFILE" option: "4= 2 Stage Type 2"]</i>
5- Absorption Stage	Constant Voltage, Absorption Stage. <i>[Parameter "CHARGING PROFILE" option: "5= 2 Stage Type 3"]</i>
E- Absorption Stage	Constant Voltage, Absorption Stage. <i>[Parameter "EQUALIZE-4STAGES" option: "1=Yes"]</i>
E- Equalization Stage	Constant Voltage, Equalization Stage. <i>[Parameter "EQUALIZE-4STAGES" option: "1=Yes"]</i>
0-Float Stage	Float Stage. <i>[Parameter "CHARGING PROFILE" option: "0 = 3 Stage Adaptive"]</i>
1- Float Stage	Float Stage. <i>[Parameter "CHARGING PROFILE" option: "1= 3 Stage Type 1"]</i>
2- Float Stage	Float Stage. <i>[Parameter "CHARGING PROFILE" option: "2 = 3 Stage Type 2"]</i>
3- Charger Off	Charger Off, AC Bypass. <i>[Parameter "CHARGING PROFILE" option: "3= 2 Stage Type 1"]</i>
5- Charger Off	Charger Off, AC Bypass. <i>[Parameter "CHARGING PROFILE" option: "5= 2 Stage Type 3"]</i>
Charger Off by BMS	Charger Off by BMS. <i>[Parameter "BATTERY TYPE" option: "1= Lithium"]</i>
Inverter Stop by BMS	Inverter Stop by BMS. <i>[Parameter "BATTERY TYPE" option: "1= Lithium"]</i>
Inverter Off	Charger only, Inverter Off. <i>[Parameter "MODE" option: "2= Charger Only"]</i>

SECTION 3 | Operation

3.6.5 Menu Map for Power Save Mode Screens

Menu Map for the Operating Mode Screens for the "Power Save" Mode are shown as follows:

- Section 3.6.5.1: Fig 3.4(a) for Models EVO-1212F / 1212F-HW / 1224F / 1224F-HW
(Model No. shown in the screens is EVO-1212F)
- Section 3.6.5.2: Fig 3.4(b) for Models (i) EVO-2212 / 3012 / 2224 / 4024 and (ii) EVO-2212E / 3012E / 2224E / 4024E
(Model No. shown in the screens is EVO-3012)
- Section 3.6.5.3: Fig 3.4(c) for Model EVO-4248SP

3.6.5.1 Menu Map for Power Save Mode Screens for EVO-1212F / 1212F-HW / 1224F / 1224F-HW

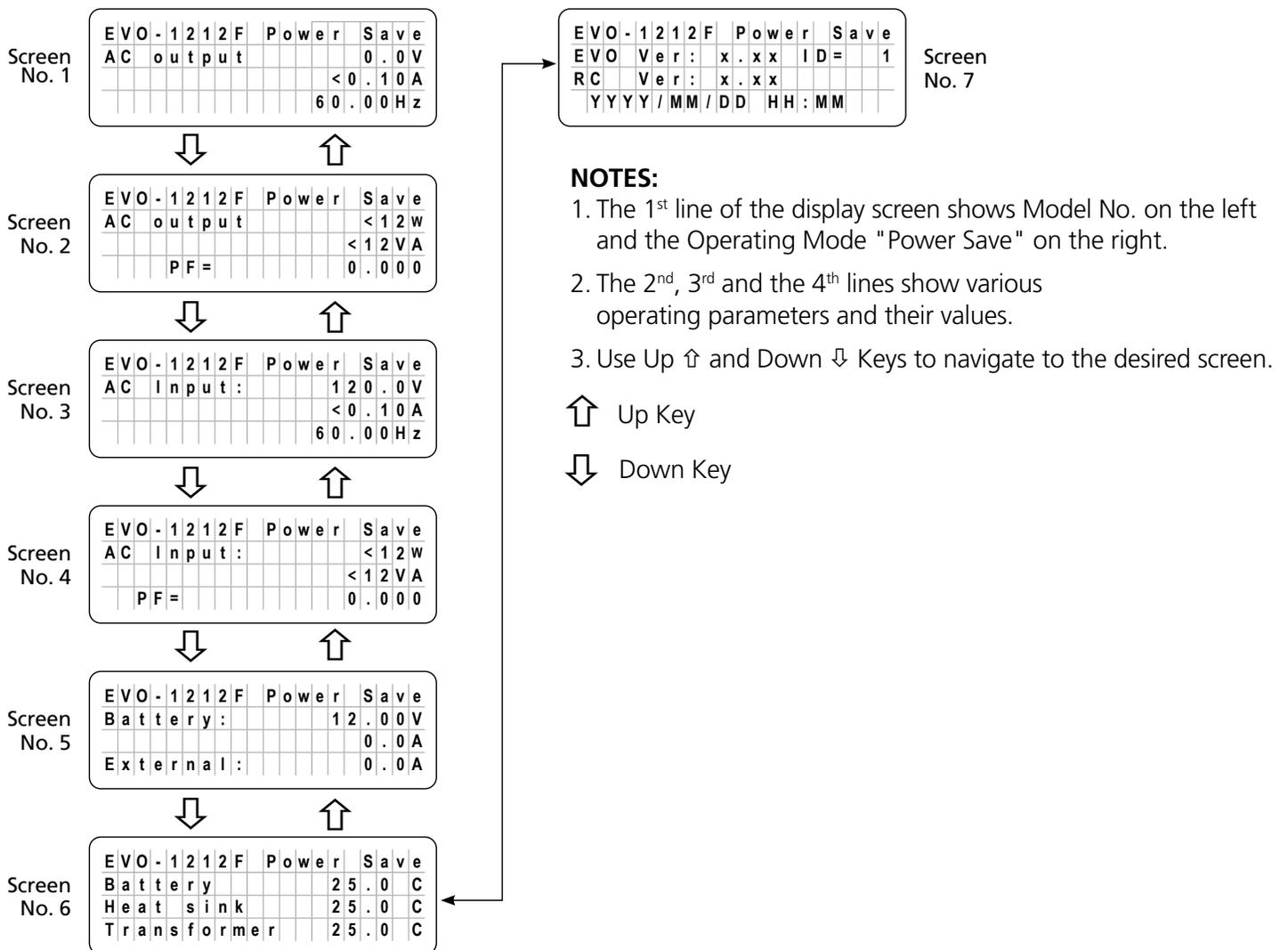

Fig 3.4(a) Menu Map for Power Save Mode Screens for Models EVO-1212F / EVO-1212F-HW / 1224F / 1224F-HW (Model No. shown is EVO-1212F)

SECTION 3 | Operation

3.6.5.2 Menu Map for Power Save Mode Screens for Models (i) EVO-2212 / 3012 / 2224 / 4024 and (ii) EVO-2212E / 3012E / 2224E / 4024E

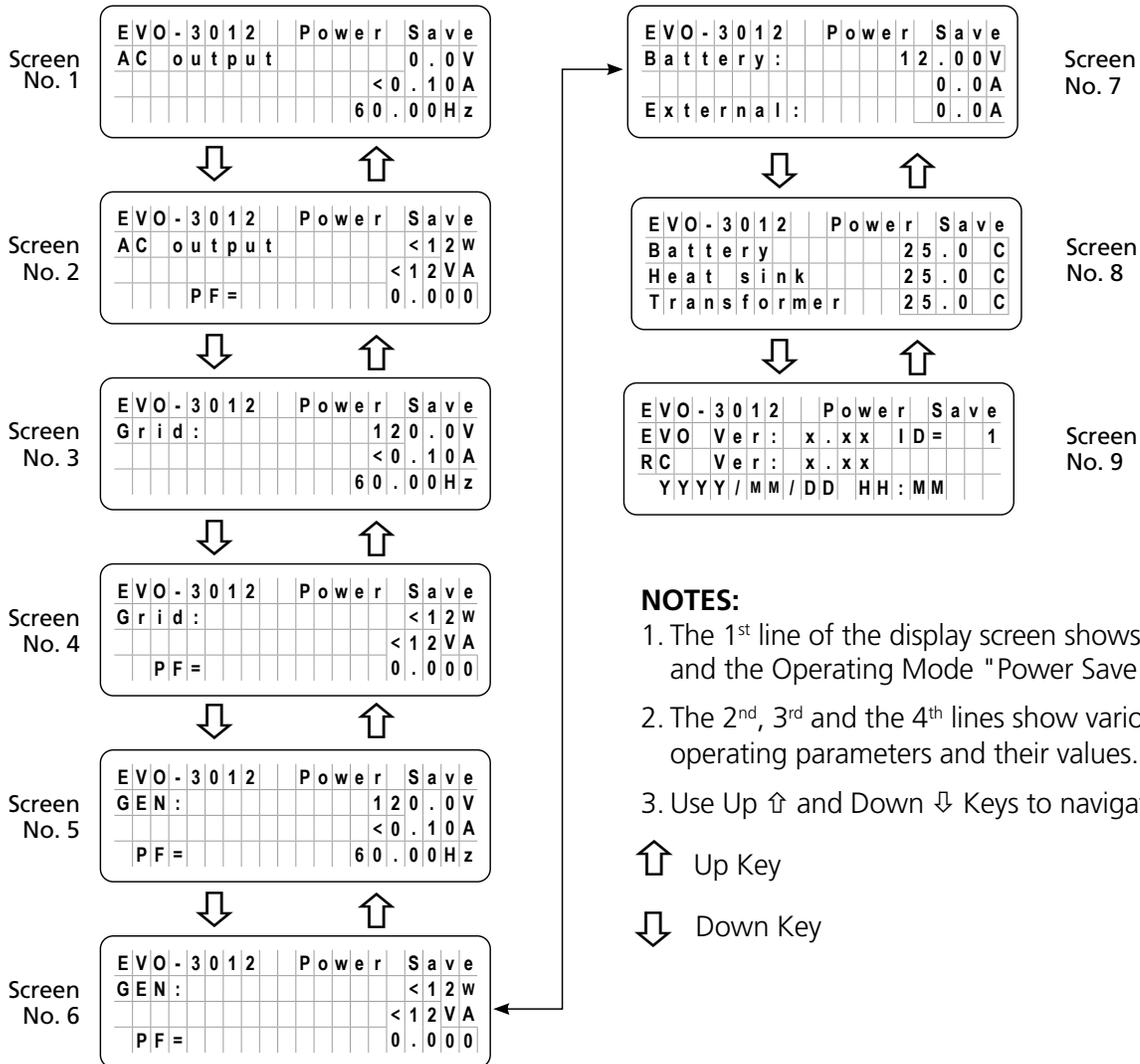

Fig 3.4(b) Menu Map for Charging Mode Screens for Models (i) EVO-2212 / 3012 / 2224 / 4024 and (ii) EVO-2212E / 3012E / 2224E / 4024E
(Model No. shown is EVO-3012)

SECTION 3 | Operation

3.6.5.3 Menu Map for Power Save Mode Screens Model EVO-4248SP

Menu Map for the Operating Mode Screens for the "Power Save" Mode are shown at Fig 3.4(c) below:

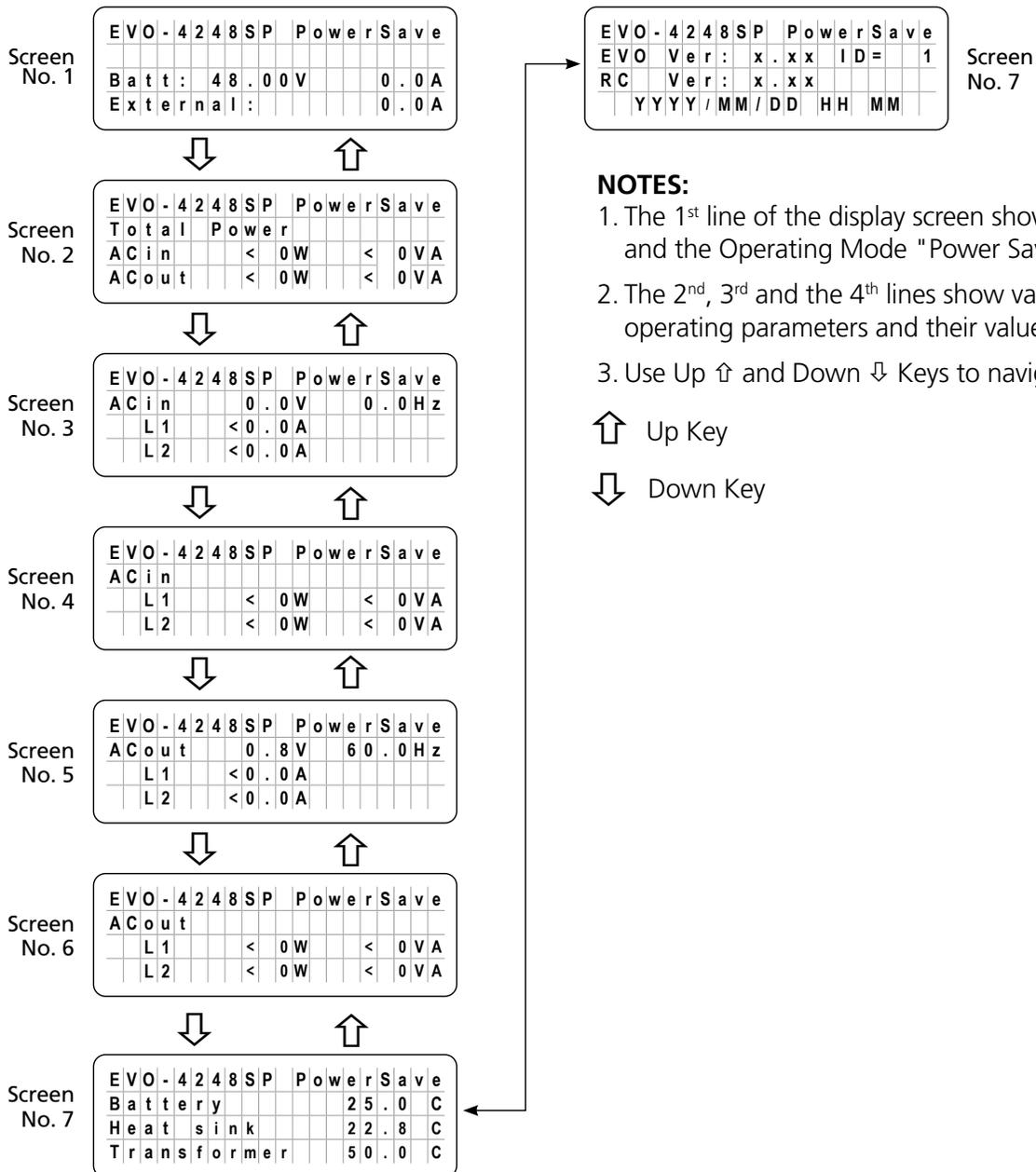

Fig 3.4(c) Menu Map for Power Save Mode Screens for Model EVO-4248SP

SECTION 3 | Operation

3.6.6 Menu Maps for On-Line Mode Screens

Menu Maps for the On-Line Mode Screens will be similar to the following Menu Map Screens for the default Off-Line Mode except for some changes explained below:

Mode	Menu Map Screens for Models EVO-1212F / 1212F-HW / 1224F / 1224F-HW	Menu Map Screens for Models EVO-2212 / 3012 / 2224 / 4024	Menu Map Screens for Model EVO-4248SP
Standby Mode	Fig 3.1(a), Section 3.6.2.1	Fig 3.1(b), Section 3.6.2.2	Fig 3.1(c), Section 3.6.2.3
Inverting Mode	Fig 3.2(a), Section 3.6.3.1	Fig 3.2(b), Section 3.6.3.2	Fig 3.2(c), Section 3.6.3.3
Charging Mode	Fig 3.3(a), Section 3.6.4.1	Fig 3.3(b), Section 3.6.4.2	Fig 3.3(c), Section 3.6.4.3
Power Save Mode	Fig 3.4(a), Section 3.6.5.1	Fig 3.4(b), Section 3.6.5.2	Fig 3.4(c), Section 3.6.5.3

In the On-Line Mode Screens, the top right of the 1st line displaying the "Operating Mode" will switch every 2 sec between "Operating Mode" and "Online Mode". Examples of screens for *EVO-1212F* and *EVO-4248SP* are shown in Figs 3.5(a) to 3.5(d) below:

EVO-1212F: Standby/Online	EVO-4248SP: Standby/Online																
<table border="1"> <tr><td>EVO-1212F</td><td>Standby</td></tr> <tr><td>AC output:</td><td>0.0V</td></tr> <tr><td></td><td><0.10A</td></tr> <tr><td></td><td>00.00Hz</td></tr> </table>	EVO-1212F	Standby	AC output:	0.0V		<0.10A		00.00Hz	<table border="1"> <tr><td>EVO-4248SP</td><td>Standby</td></tr> <tr><td>AC output:</td><td>0.0V</td></tr> <tr><td></td><td>0.0Hz</td></tr> <tr><td></td><td><0.15A <0.15A</td></tr> </table>	EVO-4248SP	Standby	AC output:	0.0V		0.0Hz		<0.15A <0.15A
EVO-1212F	Standby																
AC output:	0.0V																
	<0.10A																
	00.00Hz																
EVO-4248SP	Standby																
AC output:	0.0V																
	0.0Hz																
	<0.15A <0.15A																
↑↓ These 2 screens will switch every 2 sec	↑↓ These 2 screens will switch every 2 sec																
<table border="1"> <tr><td>EVO-1212F</td><td>Online</td></tr> <tr><td>AC output:</td><td>0.0V</td></tr> <tr><td></td><td><0.10A</td></tr> <tr><td></td><td>00.00Hz</td></tr> </table>	EVO-1212F	Online	AC output:	0.0V		<0.10A		00.00Hz	<table border="1"> <tr><td>EVO-4248SP</td><td>Online</td></tr> <tr><td>AC output:</td><td>0.0V</td></tr> <tr><td></td><td>0.0Hz</td></tr> <tr><td></td><td><0.15A <0.15A</td></tr> </table>	EVO-4248SP	Online	AC output:	0.0V		0.0Hz		<0.15A <0.15A
EVO-1212F	Online																
AC output:	0.0V																
	<0.10A																
	00.00Hz																
EVO-4248SP	Online																
AC output:	0.0V																
	0.0Hz																
	<0.15A <0.15A																

Fig 3.5(a) Example of Screen No. 1 of Online / Standby Mode Menu Map Screens

EVO-1212F: Inverting/Online	EVO-4248SP: Inverting/Online																
<table border="1"> <tr><td>EVO-1212F</td><td>Inverting</td></tr> <tr><td>AC output:</td><td>120.0V</td></tr> <tr><td></td><td><0.10A</td></tr> <tr><td></td><td>60.00Hz</td></tr> </table>	EVO-1212F	Inverting	AC output:	120.0V		<0.10A		60.00Hz	<table border="1"> <tr><td>EVO-4248SP</td><td>Inverting</td></tr> <tr><td>AC output:</td><td>240.0V</td></tr> <tr><td></td><td>60.0Hz</td></tr> <tr><td></td><td>5.00A 5.50A</td></tr> </table>	EVO-4248SP	Inverting	AC output:	240.0V		60.0Hz		5.00A 5.50A
EVO-1212F	Inverting																
AC output:	120.0V																
	<0.10A																
	60.00Hz																
EVO-4248SP	Inverting																
AC output:	240.0V																
	60.0Hz																
	5.00A 5.50A																
↑↓ These 2 screens will switch every 2 sec	↑↓ These 2 screens will switch every 2 sec																
<table border="1"> <tr><td>EVO-1212F</td><td>Online</td></tr> <tr><td>AC output:</td><td>120.0V</td></tr> <tr><td></td><td><0.10A</td></tr> <tr><td></td><td>60.00Hz</td></tr> </table>	EVO-1212F	Online	AC output:	120.0V		<0.10A		60.00Hz	<table border="1"> <tr><td>EVO-4248SP</td><td>Online</td></tr> <tr><td>AC output:</td><td>240.0V</td></tr> <tr><td></td><td>60.0Hz</td></tr> <tr><td></td><td>5.00A 5.50A</td></tr> </table>	EVO-4248SP	Online	AC output:	240.0V		60.0Hz		5.00A 5.50A
EVO-1212F	Online																
AC output:	120.0V																
	<0.10A																
	60.00Hz																
EVO-4248SP	Online																
AC output:	240.0V																
	60.0Hz																
	5.00A 5.50A																

Fig 3.5(b) Example of Screen No. 1 of Online / Inverting Mode Menu Map Screens

EVO-1212F: Charging/Online	EVO-4248SP: Charging/Online																
<table border="1"> <tr><td>EVO-1212F</td><td>Charging</td></tr> <tr><td>0-Bulk Stage</td><td></td></tr> <tr><td>Batt: 12.00V</td><td>0.0 A</td></tr> <tr><td>External:</td><td>0.0 A</td></tr> </table>	EVO-1212F	Charging	0-Bulk Stage		Batt: 12.00V	0.0 A	External:	0.0 A	<table border="1"> <tr><td>EVO-4248SP</td><td>Charging</td></tr> <tr><td>0-Bulk Stage</td><td></td></tr> <tr><td>Batt: 48.00V</td><td>32.0 A</td></tr> <tr><td>External:</td><td>0.0 A</td></tr> </table>	EVO-4248SP	Charging	0-Bulk Stage		Batt: 48.00V	32.0 A	External:	0.0 A
EVO-1212F	Charging																
0-Bulk Stage																	
Batt: 12.00V	0.0 A																
External:	0.0 A																
EVO-4248SP	Charging																
0-Bulk Stage																	
Batt: 48.00V	32.0 A																
External:	0.0 A																
↑↓ These 2 screens will switch every 2 sec	↑↓ These 2 screens will switch every 2 sec																
<table border="1"> <tr><td>EVO-1212F</td><td>Online</td></tr> <tr><td>0-Bulk Stage</td><td></td></tr> <tr><td>Batt: 12.00V</td><td>0.0 A</td></tr> <tr><td>External:</td><td>0.0 A</td></tr> </table>	EVO-1212F	Online	0-Bulk Stage		Batt: 12.00V	0.0 A	External:	0.0 A	<table border="1"> <tr><td>EVO-4248SP</td><td>Online</td></tr> <tr><td>0-Bulk Stage</td><td></td></tr> <tr><td>Batt: 48.00V</td><td>32.0 A</td></tr> <tr><td>External:</td><td>0.0 A</td></tr> </table>	EVO-4248SP	Online	0-Bulk Stage		Batt: 48.00V	32.0 A	External:	0.0 A
EVO-1212F	Online																
0-Bulk Stage																	
Batt: 12.00V	0.0 A																
External:	0.0 A																
EVO-4248SP	Online																
0-Bulk Stage																	
Batt: 48.00V	32.0 A																
External:	0.0 A																

Fig 3.5(c) Example of Screen No. 1 of Online / Charging Mode Menu Map Screens

EVO-1212F: Power Save/Online	EVO-4248SP: Power Save/Online																
<table border="1"> <tr><td>EVO-1212F</td><td>Power Save</td></tr> <tr><td>AC output:</td><td>120.0V</td></tr> <tr><td></td><td><0.10A</td></tr> <tr><td></td><td>60.00Hz</td></tr> </table>	EVO-1212F	Power Save	AC output:	120.0V		<0.10A		60.00Hz	<table border="1"> <tr><td>EVO-4248SP</td><td>Power Save</td></tr> <tr><td>Total Power</td><td></td></tr> <tr><td>AC in</td><td><36W <36VA</td></tr> <tr><td></td><td><3W <36VA</td></tr> </table>	EVO-4248SP	Power Save	Total Power		AC in	<36W <36VA		<3W <36VA
EVO-1212F	Power Save																
AC output:	120.0V																
	<0.10A																
	60.00Hz																
EVO-4248SP	Power Save																
Total Power																	
AC in	<36W <36VA																
	<3W <36VA																
↑↓ These 2 screens will switch every 2 sec	↑↓ These 2 screens will switch every 2 sec																
<table border="1"> <tr><td>EVO-1212F</td><td>Online</td></tr> <tr><td>AC output:</td><td>120.0V</td></tr> <tr><td></td><td><0.10A</td></tr> <tr><td></td><td>60.00Hz</td></tr> </table>	EVO-1212F	Online	AC output:	120.0V		<0.10A		60.00Hz	<table border="1"> <tr><td>EVO-4248SP</td><td>Online</td></tr> <tr><td>Total Power</td><td></td></tr> <tr><td>AC in</td><td><36W <36VA</td></tr> <tr><td>AC out</td><td><3W <36VA</td></tr> </table>	EVO-4248SP	Online	Total Power		AC in	<36W <36VA	AC out	<3W <36VA
EVO-1212F	Online																
AC output:	120.0V																
	<0.10A																
	60.00Hz																
EVO-4248SP	Online																
Total Power																	
AC in	<36W <36VA																
AC out	<3W <36VA																

Fig 3.5(d) Example of Screen No. 1 of Online / Power Save Menu Map Screens

SECTION 3 | Operation

3.6.7 Menu Map for "Chrg Only" (Charger Only) Mode Screens

Refer to Section 4.4.2.13.1 for details on "Charger Only" Mode

Menu Maps for Operating Mode Screens under this mode for various types of EVO™ models are shown as follows:

- Fig 3.6(a) for Models EVO-1212F / 1212F-HW / 1224F / 1224F-HW
(Model No. shown in the screens is EVO-1212F)
- Fig 3.6(b) for Models (i) EVO-2212 / 3012 / 2224 / 4024 and (ii) EVO-2212E / 3012E / 2224E / 4024E
(Model No. shown in the screens is EVO-3012)
- Fig 3.6(c) for Model EVO-4248SP

3.6.7.1 Menu Map for "Chrg Only" (Charger Only) Mode Screens for EVO-1212F / 1212F-HW / 1224F / 1224F-HW

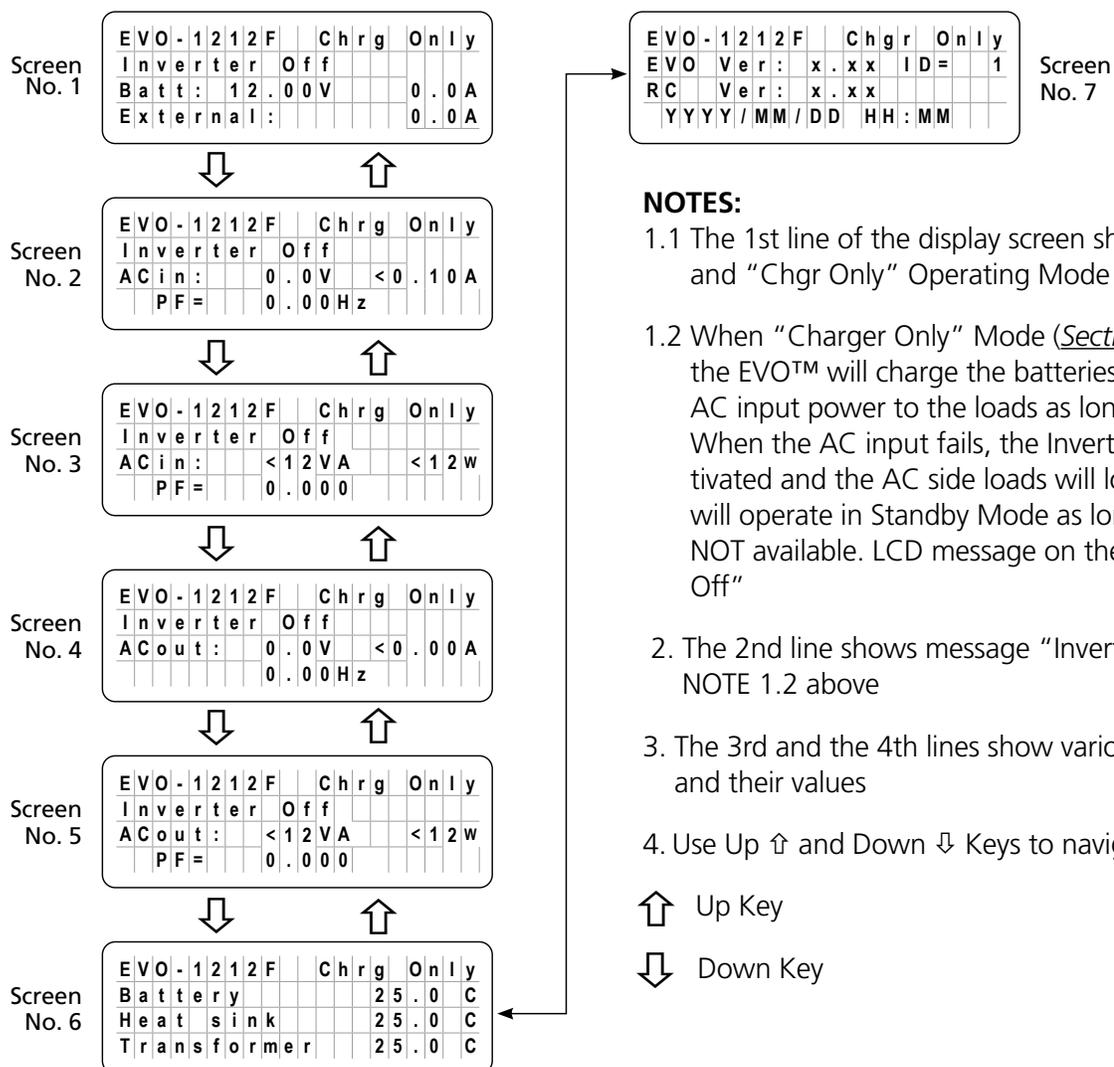
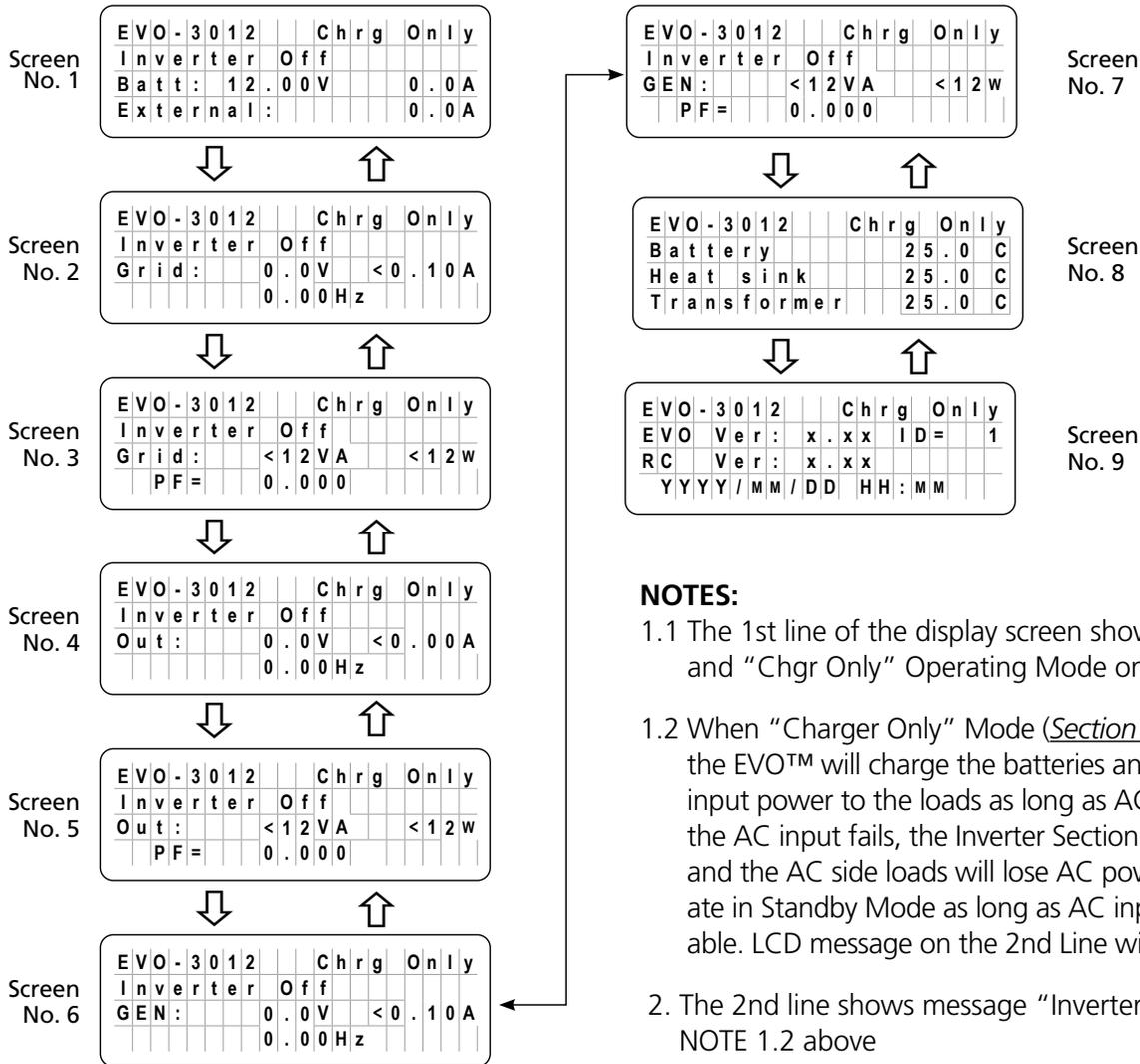

Fig 3.6(a) Menu Map for "Charger Only" Mode Screens for Models EVO-1212F / EVO-1212F-HW / 1224F / 1224F-HW (Model No. shown is EVO-1212F) When AC Input OFF

SECTION 3 | Operation

3.6.7.2 Menu Map for "Chrg Only" (Charger Only) Mode Screens for Models (i) EVO-2212 / 3012 / 2224 / 4024 and (ii) EVO-2212E / 3012E / 2224E / 4024E



NOTES:

- 1.1 The 1st line of the display screen shows Model No. on the left and "Chrg Only" Operating Mode on the right.
- 1.2 When "Charger Only" Mode ([Section 4.4.2.13.1](#)) is selected, the EVO™ will charge the batteries and pass through the AC input power to the loads as long as AC input is available. When the AC input fails, the Inverter Section will NOT be activated and the AC side loads will lose AC power. The EVO™ will operate in Standby Mode as long as AC input power is NOT available. LCD message on the 2nd Line will be "Inverter Off"
2. The 2nd line shows message "Inverter Off" as explained at NOTE 1.2 above
3. The 3rd and the 4th lines show various operating parameters and their values
4. Use Up ↑ and Down ↓ Keys to navigate to the desired screen.

↑ Up Key

↓ Down Key

Fig 3.6(b) Menu Map for "Charger Only" Mode Screens for Models (i) EVO-2212 / 3012 / 2224 / 4024 and (ii) EVO-2212E / 3012E / 2224E / 4024E
(Model No. shown is EVO-3012)

SECTION 3 | Operation

3.6.7.3 Menu Map for "Chgr Only" (Charger Only) Mode Screens for Model EVO-4248SP

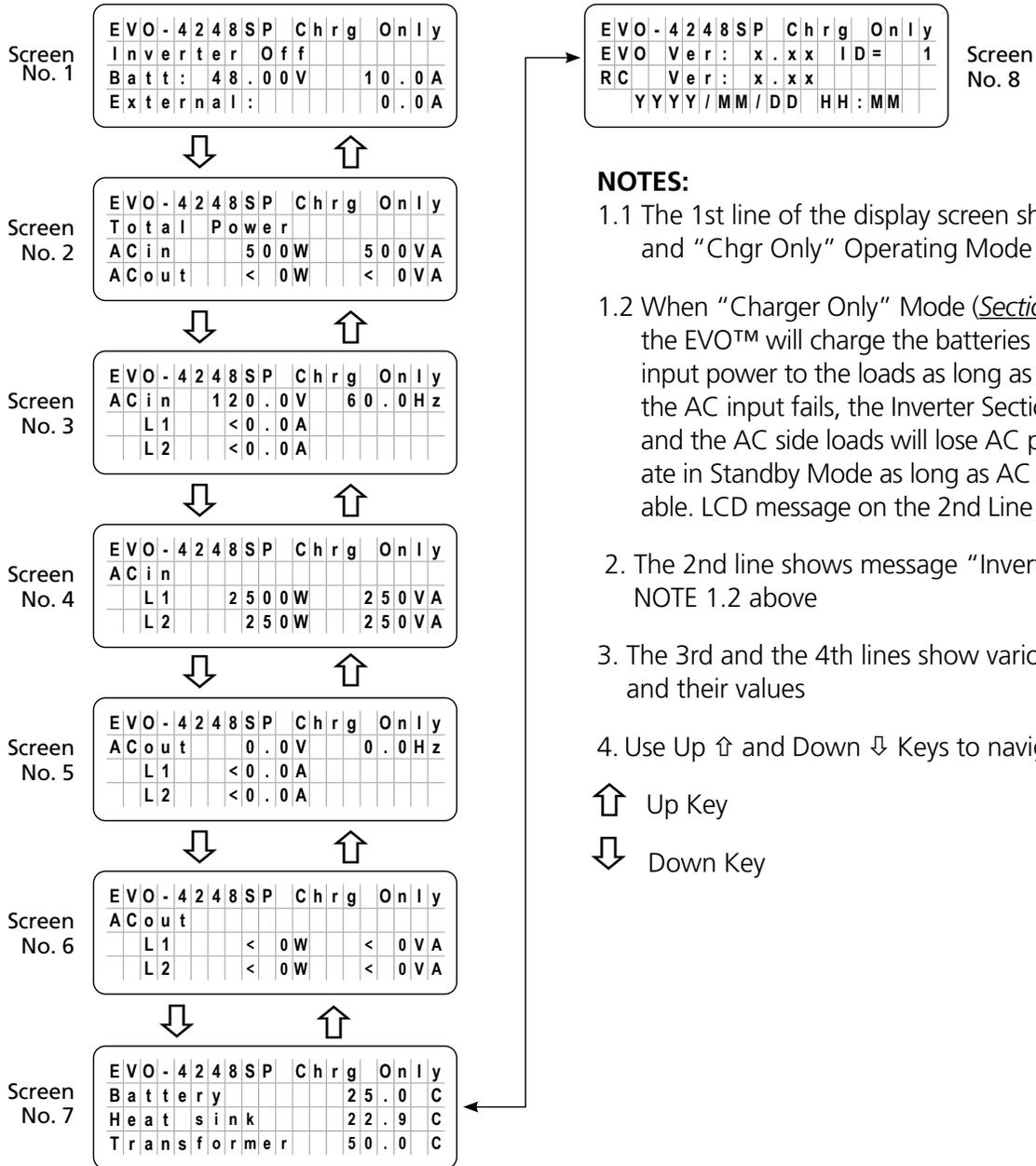

Fig 3.6(c) Menu Map for "Charger Only" Mode Screens for Model EVO-4248SP

SECTION 3 | Operation

3.6.8 Menu Maps for Charging Mode Screens When Charging is Switched Off by the Lithium Ion Battery Management System (BMS)

For background information, please refer to Sections 4.4.2.22.1 & 4.4.2.22.2

Menu Maps shown in Figs 3.7(a) to 3.7(c) for various EVO™ models are applicable when parameter "BATTERY TYPE" is set for option "1=Lithium" (See Section 4.4.2.22). Screens shown below will be seen when the Battery Management System (BMS) of the Lithium Battery sends a command (*potential free contact closure signal*) to pins 4 and 5 of the RJ-45 Temperature Sensor Jack on the EVO™ Inverter/Charger (*Temperature Sensor is not required for Lithium Battery*) to stop charging to protect the Lithium Battery from over-charge/ over temperature. Please see details at Section 4.4.2.22.

During condition of "Charger Off by BMS", AC input will continue to be passed through to the AC load(s).

When BMS resets "Stop Charging" command, normal charging will be resumed.

Menu Maps for this operating condition are shown in Figs 3.7(a) to 3.7(c).

3.6.8.1 Menu Map for Charging Mode Screens for Models EVO-1212F/EVO-1212F-HW/EVO-1224F/EVO-1224F-HW When Charging is Switched Off by Lithium Ion Battery Management System (BMS) [Refer to Fig 3.7(a)]

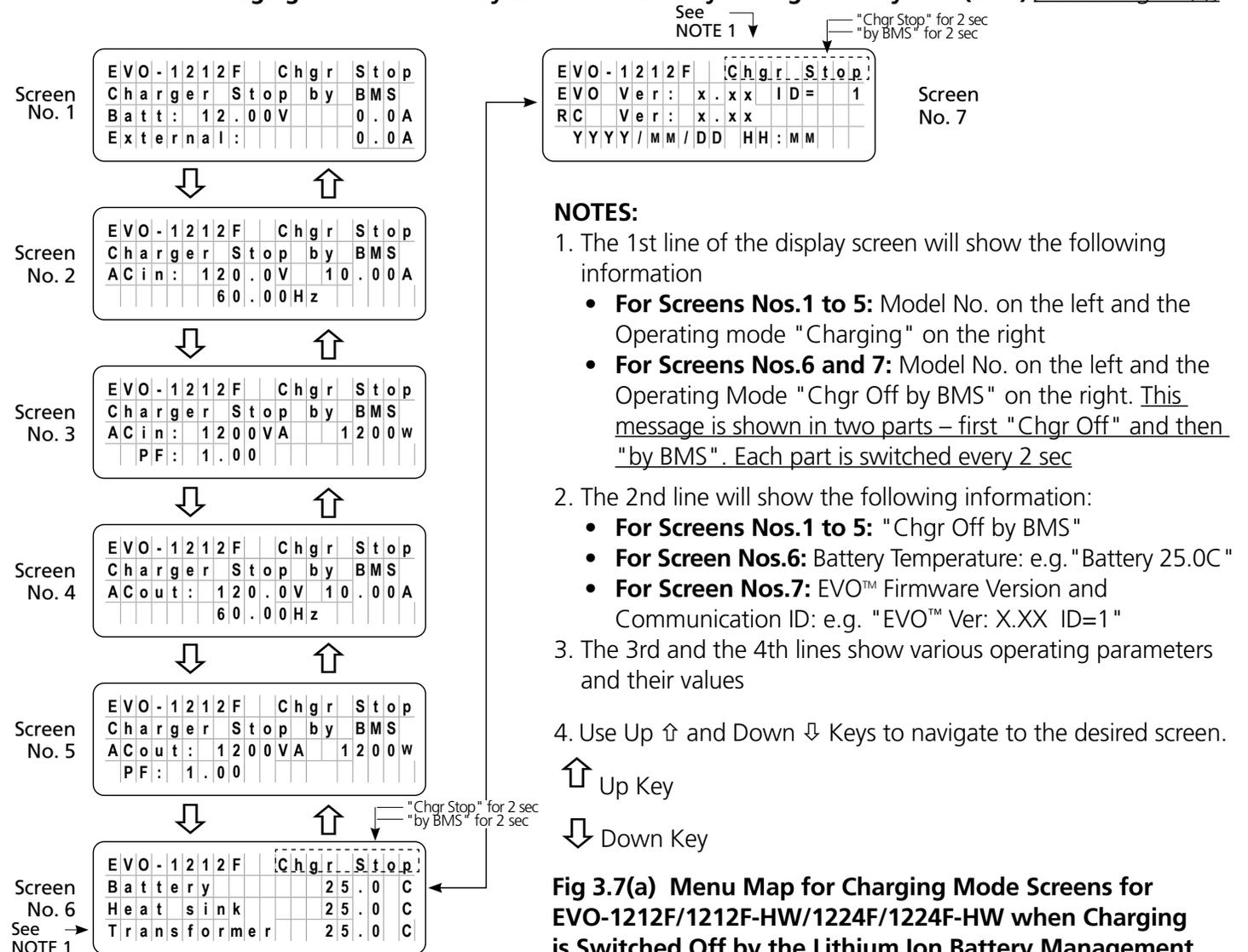

NOTES:

- The 1st line of the display screen will show the following information
 - For Screens Nos.1 to 5:** Model No. on the left and the Operating mode "Charging" on the right
 - For Screens Nos.6 and 7:** Model No. on the left and the Operating Mode "Chgr Off by BMS" on the right. This message is shown in two parts – first "Chgr Off" and then "by BMS". Each part is switched every 2 sec
- The 2nd line will show the following information:
 - For Screens Nos.1 to 5:** "Chgr Off by BMS"
 - For Screen Nos.6:** Battery Temperature: e.g. "Battery 25.0C"
 - For Screen Nos.7:** EVO™ Firmware Version and Communication ID: e.g. "EVO™ Ver: X.XX ID=1"
- The 3rd and the 4th lines show various operating parameters and their values
- Use Up ↑ and Down ↓ Keys to navigate to the desired screen.

↑ Up Key

↓ Down Key

Fig 3.7(a) Menu Map for Charging Mode Screens for EVO-1212F/1212F-HW/1224F/1224F-HW when Charging is Switched Off by the Lithium Ion Battery Management System (BMS) (Model No. shown is EVO-1212F)

SECTION 3 | Operation

3.6.8.2 Menu Map for Charging Mode Screens for Models (i) EVO-2212 / 3012 / 2224 / 4024 and (ii) EVO-2212E / 3012E / 2224E / 4024E when Charging is Switched Off by Lithium Ion Battery Management System (BMS)

Refer to Fig 3.7(b)

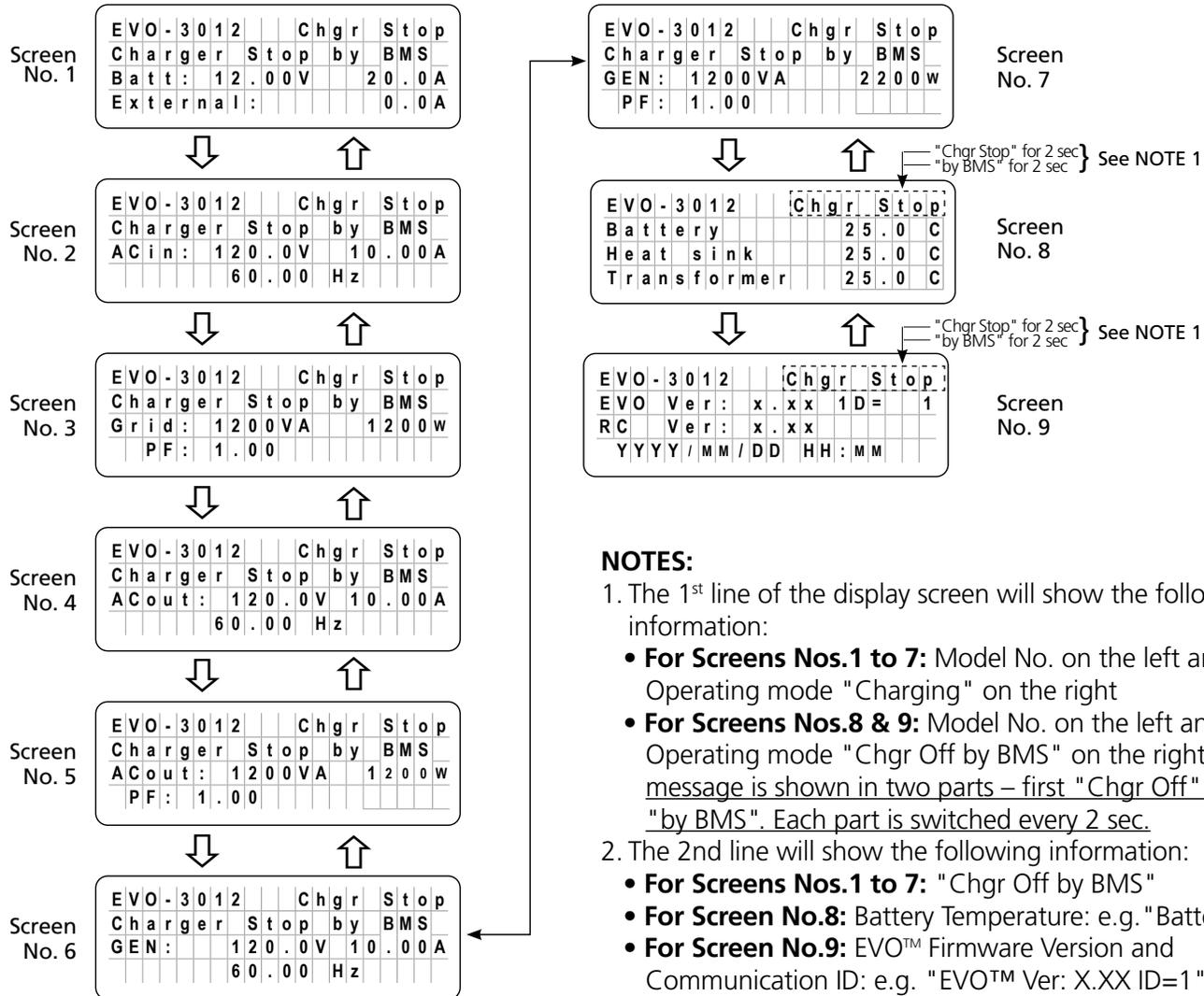

Fig 3.7(b) Menu Map for Charging Mode Screens for Models (i) EVO-2212 / 3012 / 2224 / 4024 and (ii) EVO-2212E / 3012E / 2224E / 4024E when Charging is Switched Off by Lithium Ion Battery Management System (BMS) (Model No. shown is EVO-3012)

SECTION 3 | Operation

3.6.8.3 Menu Map for Charging Mode Screens for Model EVO-4248SP when Charging is Switched Off by the Lithium Ion Battery Management System (BMS)

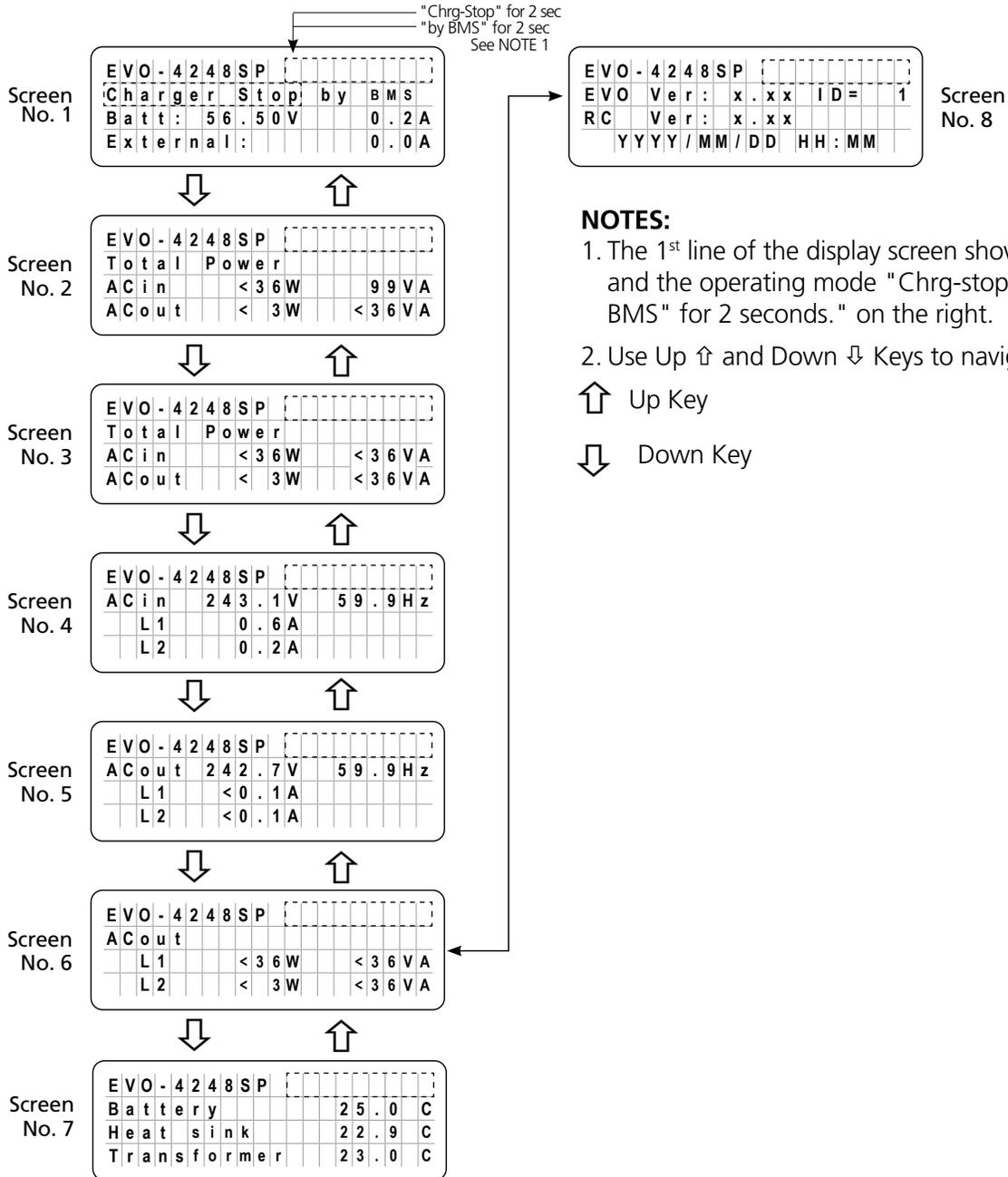

Fig 3.7(c) Menu Map for Charging Mode Screens for Model EVO-4248SP when Charging is Switched Off by the Lithium Ion Battery Management System (BMS)

SECTION 3 | Operation

3.6.9 Menu Maps for Inverting Mode Screens When Inverting is Stopped by the Lithium Ion Battery Management System (BMS)

For background information, please refer to Sections 4.4.2.22.1 & 4.4.2.22.2

Menu Maps shown in Figs 3.8(a) to 3.8(c) for various EVO™ models are applicable when parameter "BATTERY TYPE" is set for option "1 = Lithium" (See Section 4.4.2.22.1). Screens shown below will be seen when the Battery Management System (BMS) of Lithium Battery sends a command (*potential free contact closure signal*) to pins 4 and 5 of the RJ-45 Temperature Sensor Jack on the EVO™ Inverter/Charger (*Temperature Sensor is not required for Lithium Battery*) to stop inverting to protect the Lithium Battery from deep discharging condition. Please see details at Section 4.4.2.22.

Menu Maps for this operating condition are shown in Figs 3.8(a) to 3.8(c).

3.6.9.1 Menu Map for Inverting Mode Screens for Models EVO-1212F/EVO-1212F-HW/EVO-1224F/EVO-1224F-HW When Inverting is Stopped by Lithium Ion Battery Management System (BMS) [Refer to Fig 3.8(a)]

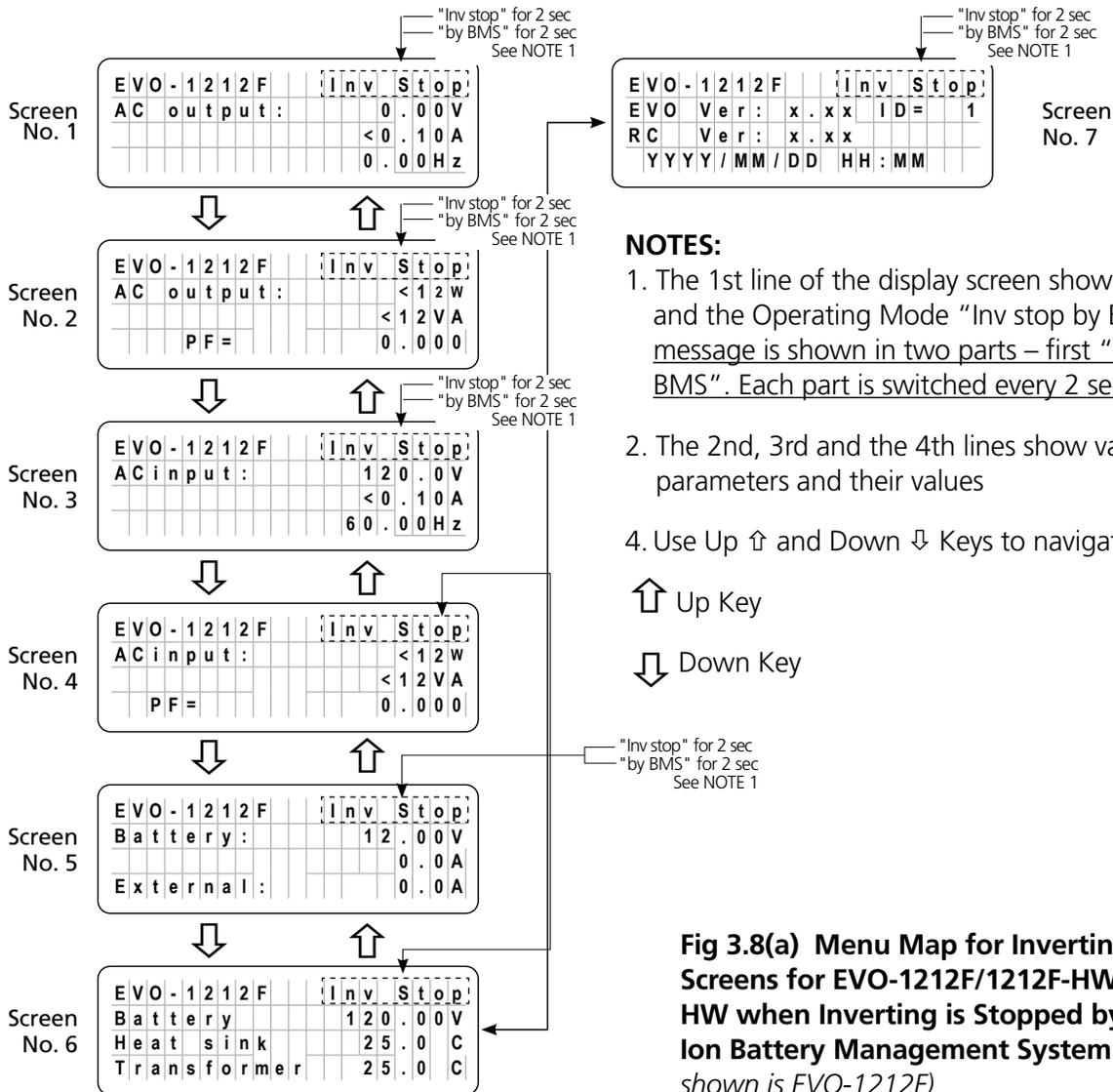

- NOTES:**
1. The 1st line of the display screen shows Model No. on the left and the Operating Mode "Inv stop by BMS" on the right. This message is shown in two parts – first "Inv stop" and then "by BMS". Each part is switched every 2 sec.
 2. The 2nd, 3rd and the 4th lines show various operating parameters and their values
 4. Use Up ↑ and Down ↓ Keys to navigate to the desired screen.
- ↑ Up Key
↓ Down Key

Fig 3.8(a) Menu Map for Inverting Mode Screens for EVO-1212F/1212F-HW/1224F/1224F-HW when Inverting is Stopped by the Lithium Ion Battery Management System (BMS) (Model shown is EVO-1212F)

SECTION 3 | Operation

3.6.9.2 Menu Map for Inverting Mode Screens for Models (i) EVO-2212 / 3012 / 2224 / 4024 and (ii) EVO-2212E / 3012E / 2224E / 4024E when Inverting is Stopped by Lithium Ion Battery Management System (BMS)

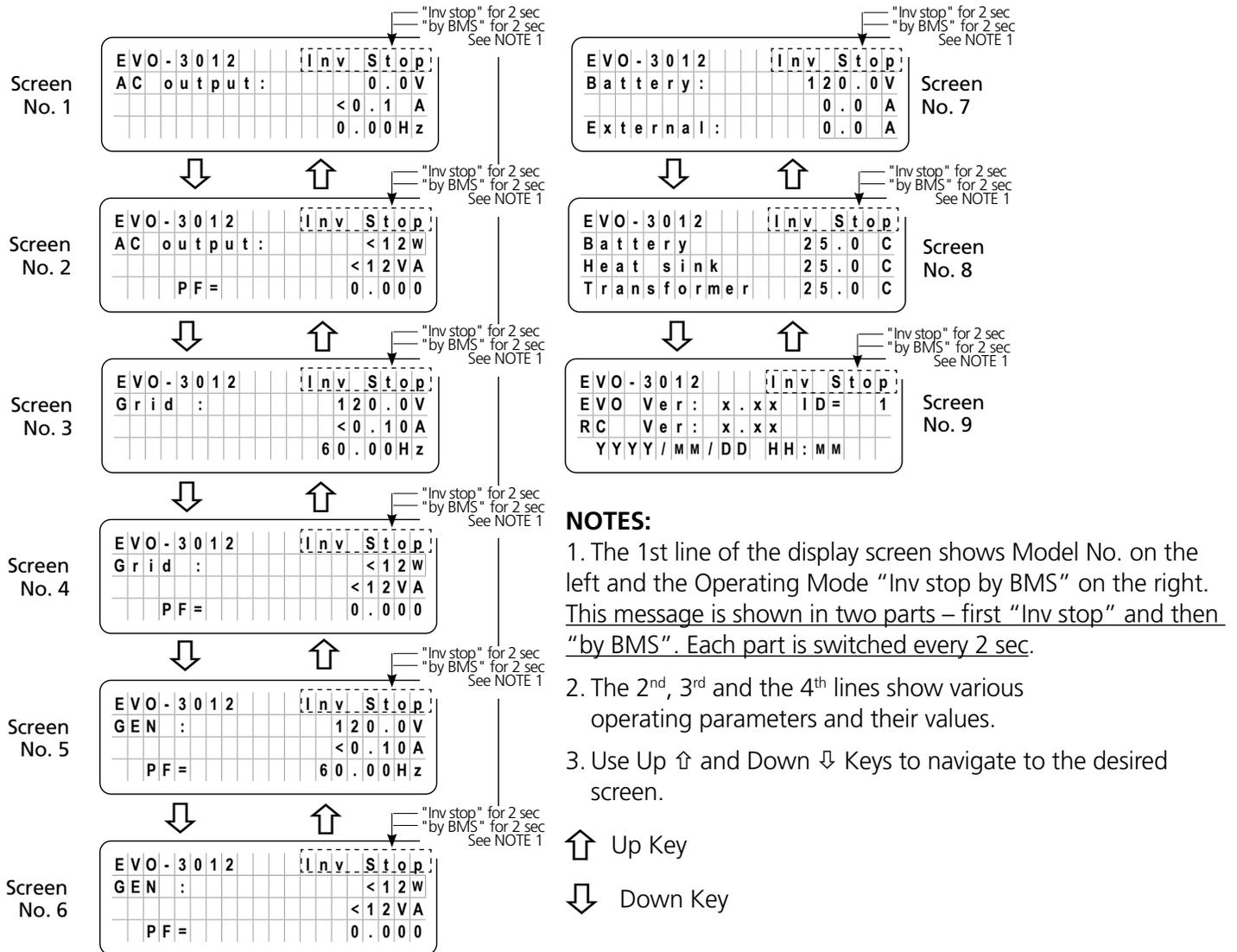

NOTES:

1. The 1st line of the display screen shows Model No. on the left and the Operating Mode "Inv stop by BMS" on the right. This message is shown in two parts – first "Inv stop" and then "by BMS". Each part is switched every 2 sec.
2. The 2nd, 3rd and the 4th lines show various operating parameters and their values.
3. Use Up \uparrow and Down \downarrow Keys to navigate to the desired screen.

\uparrow Up Key
 \downarrow Down Key

Fig 3.8(b) Menu Map for Inverting Mode Screens for Models (i) EVO-2212 / 3012 / 2224 / 4024 and (ii) EVO-2212E / 3012E / 2224E / 4024E when Inverting is Stopped by the Lithium Ion Battery Management System (BMS) (Model No. shown is EVO-3012)

SECTION 3 | Operation

3.6.9.3 Menu Map for Inverting Mode Screens for Model EVO-4248SP When Inverting is Stopped by the Lithium Ion Battery Management System (BMS)

Refer to Fig 3.8(c)

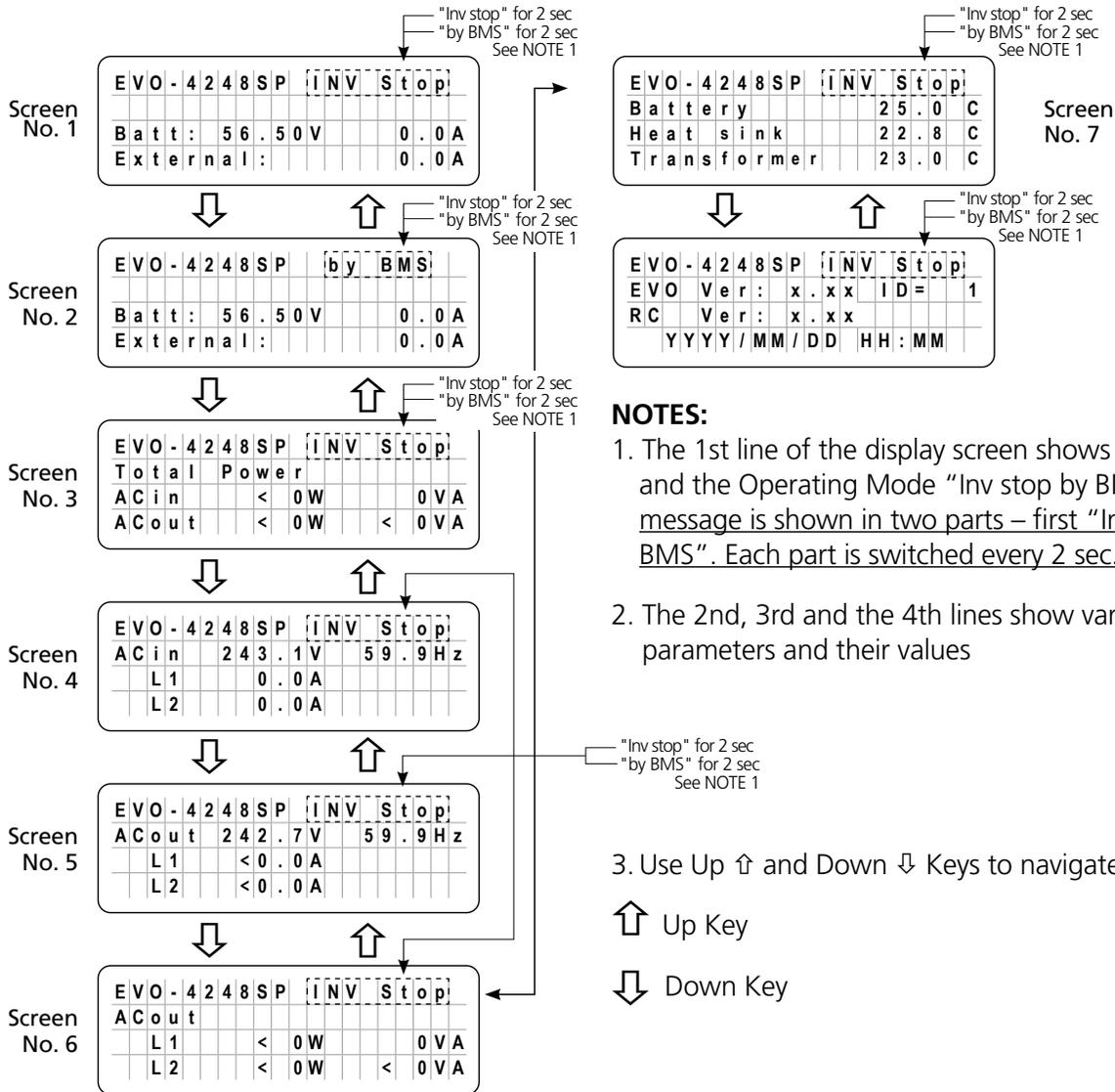

Fig 3.8(c) Menu Map for Inverting Mode Screens for Model EVO-4248SP when Inverting is Stopped by the Lithium Ion Battery Management System (BMS)

SECTION 4 | Parameter Setup

4.0 "SELECT GROUP" AND "SELECT PARAMETER" MENU MAPS

4.1.1 General Information

A number of operating parameters can be programmed to suit the desired operating conditions. The programming parameters have been arranged under 7 groups displayed as "SELECT GROUP" as per details at Table 4.1 below. "Select Group" Menu Map for accessing the 7 Parameter Groups is shown at Fig 4.1.

"Select Group" Screen No.	"Select Group" Name	Description	"Select Group" Menu Map
1	CHARGE CURVE	Group of parameters for battery charging/battery protection	Fig 4.1
2	INPUT SETTING	Group of parameters for Grid/Generator input current level, frequency range	
3	INPUT LOW LIMIT	Group of parameters for Grid/Generator input low voltage level	
4	INPUT HIGH LIMIT	Group of parameters for Grid/Generator input high voltage level	
5	OTHER FUNCTION	Group of parameters Power Saving/Buzzer/Remote Switch/Multi-function Relay/etc.	
6	RC PLUS SETTINGS	RC Plus Settings	
7	TIME SETTING	1 parameter for Real Time Clock setting	
8	STOP SD CARD	NOTE: Shown only when SD Card is inserted. 1 parameter to stop SD Card access and to remove the SD Card.	

The 1st screen for "Select Group" - CHARGE CURVE will be accessed when Enter Key is pressed momentarily from any of the Operating Mode Display Screens detailed at Table 3.1.

Fig 4.1 shows "Select Group" Menu Map for the 8 Parameter Groups. Use the Up and Down keys to navigate to the desired Parameter Group or the Back key to go back to the Operating Mode Screen. Press Enter to access Parameters in the selected Parameter Group.

For explanation of the format of the "Select Group Screens" shown in Fig 4.1, consider Group 1 Screen - CHARGE CURVE. The 1st line shows the action i.e. "Select Group". The 2nd line shows the name of the "Select Group" - CHARGE CURVE with an asterisk sign * against it. The asterisk sign * indicates that this Group will be selected when Enter Key is pressed. When Enter Key is pressed, access will be available for parameters under this group.

SECTION 4 | Parameter Setup

4.1.3 "Select Parameter" Menu Map

When any of the 8 Parameter Groups from the "Select Group" Menu Map (*Fig 4.1*) is selected, access is available to the "Select Parameter" Menu Map pertaining to that Group. Location of "Select Parameter" Menu Maps are given in Table 4.2.

"Select Group" Menu Map (<i>Fig 4.1</i>) Column (1)	Location of "Select Parameter" Menu Map Column (2)	Location of TABLES for Parameter details Column (3)
Group 1 - CHARGE CURVE	Fig 4.2, Section 4.1.3.1	Table 4.3 (<i>Section 4.4</i>)
Group 2 - INPUT SETTING	Fig 4.3, Section 4.1.3.2	Table 4.6 (<i>Section 4.5</i>)
Group 3 - INPUT LOW LIMIT	Fig 4.3, Section 4.1.3.2	Table 4.7 (<i>Section 4.6</i>)
Group 4 - INPUT HIGH LIMIT	Fig 4.3, Section 4.1.3.2	Table 4.8 (<i>Section 4.7</i>)
Group 5 - OTHER FUNCTION	Fig 4.4, Section 4.1.3.3	Table 4.9 (<i>Section 4.8</i>)
Group 6 - RC PLUS SETTING	Fig 4.5, Section 4.1.3.4	Table 4.10 (<i>Section 4.9</i>)
Group 7 - TIME SETTING	Fig 4.6, Section 4.1.3.5	Section 4.10
Group 8 - STOP SD CARD	Fig 4.6, Section 4.1.3.5	Section 4.11

NOTE: Figs 4.2 to 4.4 show the default/factory preset parameters for EVO-1212F / 1212F-HW. For parameters for other Models, refer to Tables shown under Column (3) of Table 4.2.

For explanation of the format of the "Select Parameter" screen, refer to Fig 4.2, Screen No. 1 - "Select Parameter" - BULK CURRENT (*extract given below*):

Screen No. 1

	S	e	l	e	c	t	P	a	r	a	m	e	t	e	r	
			C	H	A	R	G	E	C	U	R	V	E			
*			B	U	L	K	C	U	R	R	E	N	T			
							2	0	A							

NOTE: The information in this screen pertains to Model No. EVO-1212F

- The 2nd line shows the Parameter Group - CHARGE CURVE in this case
- The 3rd line - "BULK CURRENT" in this case shows that this parameter is earmarked for programming. The asterisk * against this line shows that this parameter will be accessed for programming when Enter Key is pressed.
- The 4th line shows the default/factory preset value for BULK CURRENT (*20A for EVO-1212F / 1212F-HW*).
- Refer to Tables shown in Column 3 of TABLE 4.2 above for parameter details for various models.

SECTION 4 | Parameter Setup

4.1.3.1 "Select Parameter" Menu Map for Parameter Group 1: CHARGE CURVE

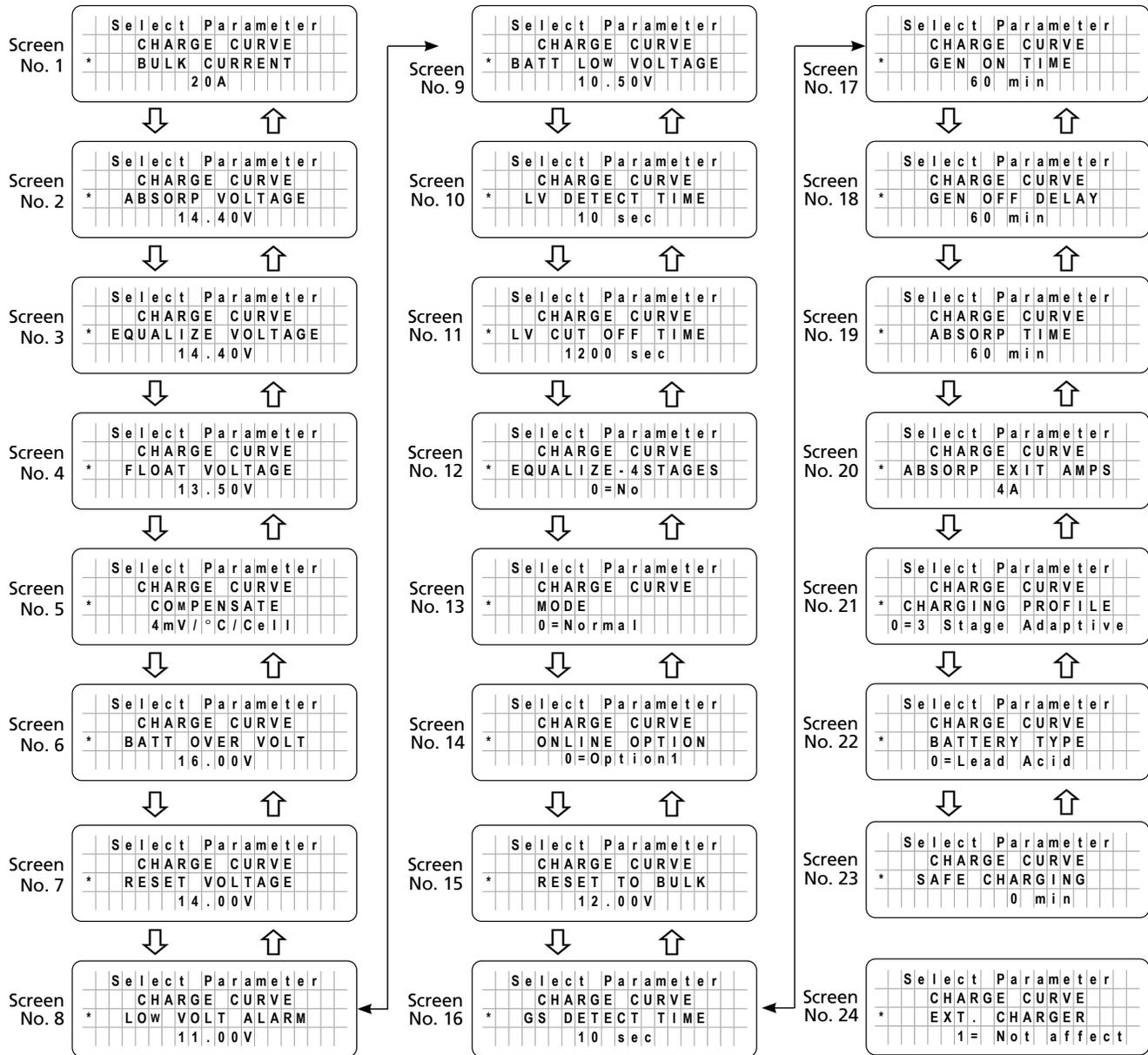

NOTES:

1. Value shown in the 4th line of the display screen is the default / factory pre-set values (*EVO-1212F / 1212F-HW in this case*). Refer to Table 4.3 (*Section 4.4.1*) for the default / factory pre-set values and additional programming details for the other Models
2. Asterisk sign * in the beginning of the 3rd line of the display screen points that the parameter shown in this line will be selected for further programming when the Enter Key is pressed
3. Use Up ↑ and Down ↓ Keys to navigate to the desired screen.

↑ Up Key
 ↓ Down Key

Fig 4.2 "Select Parameter" Menu Map for Parameter Group 1 - CHARGE CURVE

SECTION 4 | Parameter Setup

4.1.3.2 "Select Parameter" Menu Maps for (i) Parameter Group 2: INPUT SETTING, (ii) Parameter Group 3: INPUT LOW LIMIT and (iii) Parameter Group 4: INPUT HIGH LIMIT.

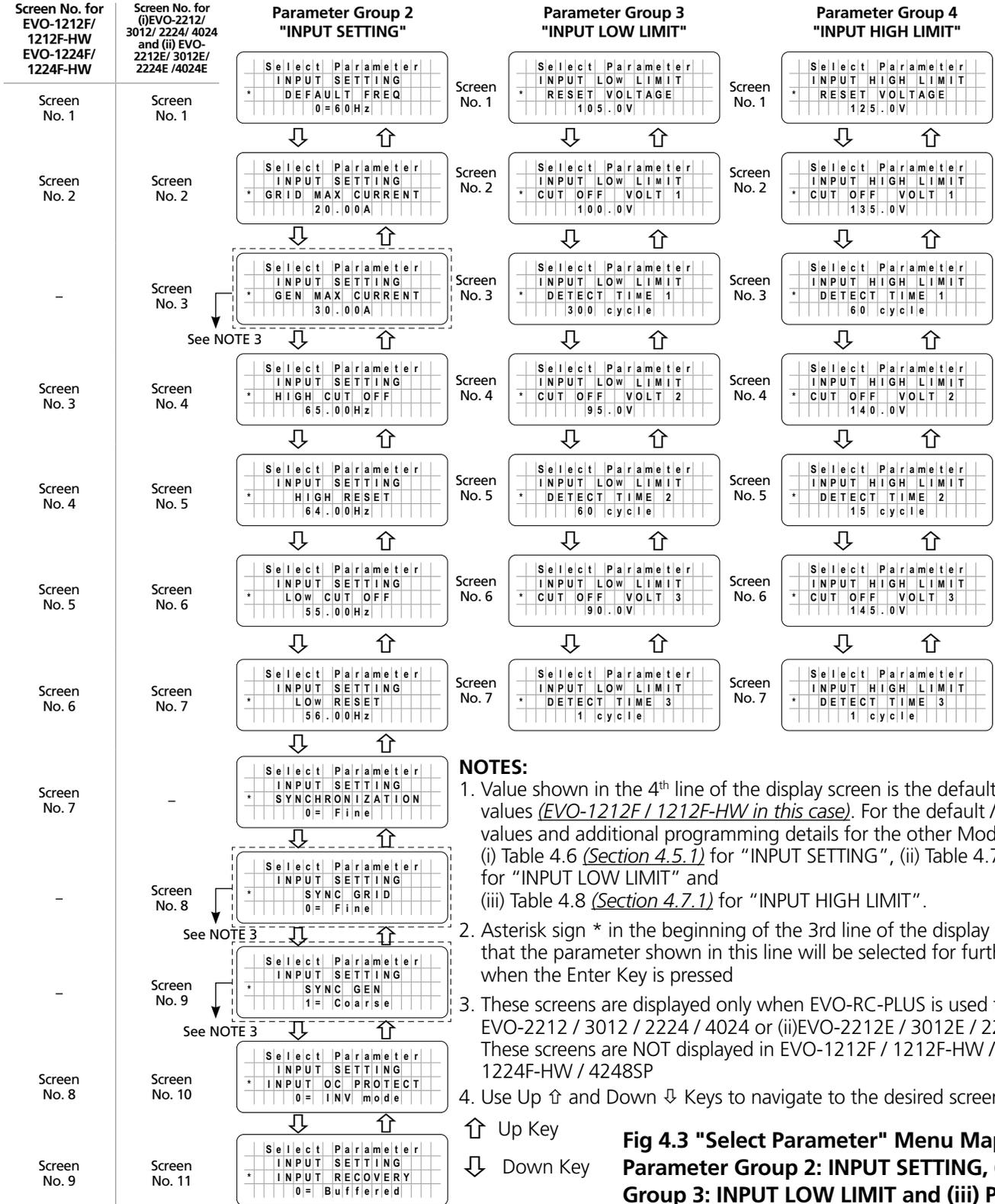

↑ Up Key
↓ Down Key

Fig 4.3 "Select Parameter" Menu Maps for (i) Parameter Group 2: INPUT SETTING, (ii) Parameter Group 3: INPUT LOW LIMIT and (iii) Parameter Group 4: INPUT HIGH LIMIT.

SECTION 4 | Parameter Setup

4.1.3.3 "Select Parameter" Menu Map for Parameter Group 5: OTHER FUNCTION

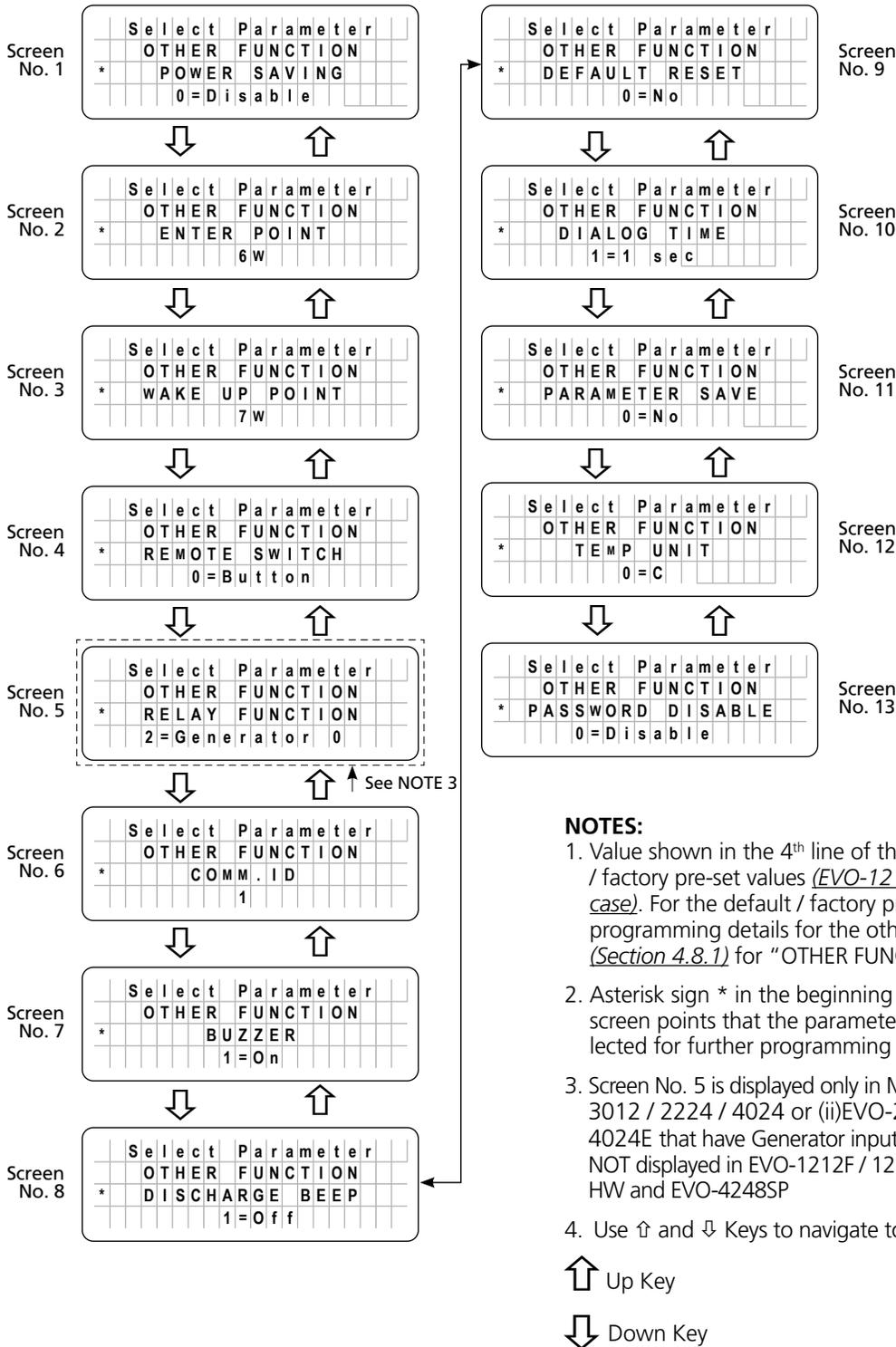

Fig 4.4 "Select Parameter" Menu Map for Parameter Group 5: OTHER FUNCTION

SECTION 4 | Parameter Setup

i INFO

There is a 30 second timeout for setting parameters; after 30 seconds the Setting Mode will be cancelled and the display will revert to the Operating Mode Screen associated with current operation.

It is highly recommended to set the EVO™ Date and Time (*Parameter Group 7, Screen No. 7 in Fig 4.1*) as this value is used to record data logging files. (*Refer to Section 4.10 for Date and Time set up*).

➡ Press Enter Key

⏴ Press Down Key

⏪ Press Back Key

⏵ Press Up Key

Any Operating Mode Screen from Fig 3.1 to 3.8

EVO-1212F	Inverting
AC output:	120.0V
	< 0.10 A
	60.00 Hz

⏪ Screen No. 1 for Group 1

"Select Group" Menu Map (Fig 4.1)

Select Group
* CHARGE CURVE

"Select Parameter" Screen (Figs 4.2 to 4.5)
(eg. BULK CURRENT: Screen No. 1, Fig 4.2)

Select Parameter
CHARGE CURVE
* BULK CURRENT
20 A

⏴ Screen No. 2 for Group 2

Select Group
* INPUT SETTING

⏴ Screen No. 3 for Group 3

Select Group
* INPUT LOW LIMIT

⏴ Screen No. 4 for Group 4

Select Group
* INPUT HIGH LIMIT

⏴ Screen No. 5 for Group 5

Select Group
* OTHER FUNCTION

⏴ Screen No. 6 for Group 6

Select Group
* RC-PLUS SETTING

⏴ Screen No. 7 for Group 7

Select Group
* TIME SETTING

⏴ Screen No. 8 for Group 8

Select Group
* STOP SD CARD

NOTE:
Will be displayed only when SD Card is inserted.

Fig 4.7 Example - Navigating from Operating Mode Screen to "Select Parameter" Screen for Parameter "BULK CURRENT"

SECTION 4 | Parameter Setup

4.2.2 Changing / Entering Parameter Values

Each parameter has a programmable range of values specific to the model number of the EVO™. Please refer to Tables 4.3 and 4.6 to 4.10 and Sections 4.10 and 4.11 for details. **During parameter programming**, the displayed numerical value of the parameter consists of multiple digits that are necessary to display the highest numerical value within the programmable range. For example, the programmable range for the parameter BULK CURRENT for EVO-1212F / 1212F-HW is 0-60A (*Table 4.3, Section 4.4.1*). The highest numerical value is "60" and consists of 2 digits. Hence, for EVO-1212F / 1212F-HW, the numerical value of BULK CURRENT will be displayed /entered as 2 digits. For example, 1A will be displayed / entered as "1A"; 20A will be displayed / entered as "20A" and so on. The overall numerical value of the parameter is changed digit by digit starting from the 1st digit on the left. On entering the desired "Select Parameter" Screen (*Figs 4.2 to 4.6*), a cursor will appear under the 1st digit and the cursor and the digit will be blinking. Scroll to the desired numerical value for the 1st digit using Up and Down Keys. Press the Enter Key **momentarily** to write the desired numerical value for the 1st digit. The cursor will automatically move to the 2nd digit on the right. The 2nd digit and the cursor and the digit will be blinking. Scroll to the desired numerical value for the 2nd digit with the help of Up and Down Keys. Then, press the Enter Key **momentarily** to write the desired numerical value for the 2nd digit. The overall numerical value of the parameter will be selected after scrolling to the desired numerical value for the **last digit**. Now, press the Enter Key, **HOLD for 3 to 4 sec and then release**. Process for writing the overall numerical value of the parameter into the memory will be initiated – the screen will display message "Writing..." followed by message "Write Success!".

Please read Section 4.3.1 for example of programming a typical parameter – BULK CURRENT



1. When the numerical value for any individual digit is changed that makes the overall numerical value of the parameter outside the programmable range, an Exclamation Sign "!" will appear on the left of the display screen warning you to correct the overall numerical value of the parameter to within the programmable range before writing the new overall numerical value of the parameter to memory. See Tables 4.3 and 4.6 to 4.10 and Sections 4.10 and 4.11 for programmable ranges.
2. If, after scrolling to the desired numerical value for the last digit, the overall numerical value of the parameter is out of the programmable range, the Exclamation Sign "!" will continue to appear on the left of the display screen. If an attempt is made to write this "out of range overall numerical value" into the memory (*by pressing and holding the Enter Key when the cursor is at the last digit*), message "Out of range!" will be displayed and the screen will go back to display the originally stored value of the parameter. **Parameter set up procedure will have to be re-started.**
3. If there is some problem in writing to the memory, message "Write failure!" will be displayed. **Parameter set up procedure will have to be re-started.**

4.3 PASSWORD PROTECTION FOR PARAMETER CHANGE

In the factory preset (*Default*) condition, all parameters except Time and Date are protected with a Password. This is considered to prevent accidental / unintentional changes of parameter values. When the required "Select Parameter" Screen is reached and is displayed and **Enter** Key is pressed to modify the parameter value, the system will request a 4-digit Password. **The Password is 8052**. Once you **Enter** the Password correctly, you don't need to enter the Password again until any Key is not pressed for over 60 seconds. An example of Parameter setting is shown at Section 4.3.1. **NOTE: Password protection may be disabled, if required – See Section 4.3.2.**

SECTION 4 | Parameter Setup

4.3.1 Example of Password Activation and Changing Bulk Current Setting for EVO-1212F / 1212F-HW from Default Value of 20A to 50A

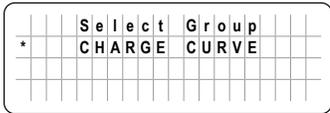

Starting from any of the 5 Operating Mode Screens (*shown at Figs 3.1 to 3.8*), press **Enter** Key. Screen "Select Group, CHARGE CURVE" as shown on the left will be displayed (*Parameter Group 1 of "Select Group" Menu Map, Fig 4.1*)

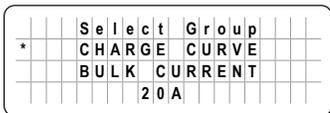

Press **Enter** key to access 24 Parameter Screens under "Select Parameter" Menu Map for Parameter Group 1 "Charge Curve" (*Fig 4.2*) [Parameters are detailed at Table 4.3 under Section 4.4.1].

Screen "BULK CURRENT, 20A" as shown on the left will be displayed (*Screen No.1 of "Select Parameter" Menu Map for Parameter Group 1: CHARGE CURVE at Fig 4.2*). Default current setting of 20A or previously set value will be displayed.

Press **Enter** Key to change Bulk Current parameter setting. A Password will be requested. Password will NOT be requested if disabled - see Section 4.3.2.

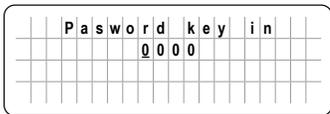

Password consisting of 4 digits "0000" will be requested as shown on the left (**NOTE:** Password to be entered is 8052). The first digit will have a blinking cursor "_". Use **Up /Down** Keys to scroll to number 8 for the first digit "8" of the password. **Momentarily** press **Enter Key** (*Short* press). Digit 8 will be entered as the first digit of the Password and the blinking cursor will automatically move to the 2nd digit (0) to the right. As the next digit in the Password "8052" is already "0", **momentarily** press **Enter Key** (*Short* press) to enter "0" in the second digit. The blinking cursor will automatically move to the 3rd digit (0). Use **Up /Down Keys** to scroll to number 5 for the 3rd digit "5" of the password "8052" and **momentarily** press **Enter Key** (*Short* press). The blinking cursor will automatically move to the 4th digit (0). Use **Up /Down** Keys to scroll to number 2 for the 4th digit "2" of the password "8052". Now keep the **Enter Key pressed continuously for longer time** (3 to 4 sec) to write the full password of 4 digits i.e. "8052".

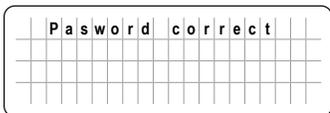

Flashes twice when Password is correct. (8052)

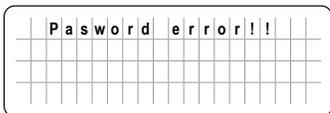

Flashes twice when Password is NOT correct.

SECTION 4 | Parameter Setup

	S	e	t	u	p	P	a	r	a	m	e	t	e	r		
	C	H	A	R	G	E	C	U	R	V	E					
*	B	U	L	K	C	U	R	R	E	N	T					
							2	0	A							

Screen No.1 of the "Select Parameter - CHARGE CURVE" for BULK CURRENT setting appears as shown on the left.. The Default Value of 20A will be displayed as "20" using 2 digits. There will be a blinking cursor under the 1st digit ("2"). The 1st digit ("2") will also blink. To change the setting to the new value of 50A, the 2 digits will have to be changed from "20" to "50" one by one as follows:

- Press the Up Key to scroll the 1st digit to "5". Press the Enter Key **MOMENTARILY** to select "5" for the 1st digit. The blinking cursor will automatically move to the 2nd digit "0". The 2nd digit "0" will be blinking.
- As the 2nd digit of the new setting "50" is already "0", there is no need to change this value. Now, the overall numerical value will be "50". The cursor and "0" at the 2nd digit will be blinking.
- Press the Enter Key, **HOLD for 3 to 4 sec and then release** to write the new value of 50A into the memory.

	W	r	i	t	e	s	u	c	c	e	s	s	!			

Flashes twice when writing is successful.

End of setting.

	S	e	t	u	p	P	a	r	a	m	e	t	e	r		
	C	H	A	R	G	E	C	U	R	V	E					
*	B	U	L	K	C	U	R	R	E	N	T					
							2	0	A							

Press **Back** Key to go back to the previous level "Select Group - CHARGE CURVE" or **Up/Down** Key to the other parameter(s) within the Select "Parameter - CHARGE CURVE".

	S	e	t	u	p	P	a	r	a	m	e	t	e	r		
	C	H	A	R	G	E	C	U	R	V	E					
*	B	U	L	K	C	U	R	R	E	N	T					
!							9	0	A							

An exclamation sign '!' is shown when the parameter is out of the specified programming range. For example, if 90A was entered for EVO-1212F / 1212F-HW (EVO-1212F / 1212F-HW (programmable range is 0-60A)), it will be out of range and an exclamation sign '!' will be displayed.

	W	r	i	t	e	f	a	i	l	u	r	e	!			

Flashes twice when there is a write failure.

	O	u	t	o	f	r	a	n	g	e	!					

Flashes twice when the set value is out of range. (90 A is out of range for EVO-1212F).

Details of all the programmable parameters, their programmable ranges and default values are detailed in Section 4.4 to 4.10.

SECTION 4 | Parameter Setup

4.3.2 Disabling Password Protection

In the default / factory preset condition, Password Protection is enabled.

Password Protection may be disabled, if required.

Procedure is given below:

1. Press ENTER Key momentarily from any Operating Mode Screen (*see details at Table 3.1*)

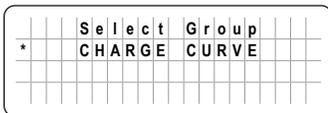

- Screen No. 1 of "Select Group * CHARGE CURVE" (*Fig 4.1*) will appear as shown on the left.

2. Press "Down Key" 4 times to scroll to "*OTHER FUNCTION" screen.

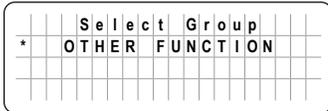

- Screen No. 5 of "Select Group * OTHER FUNCTION" (*Fig 4.1*) will appear as shown on the left.

3. Press ENTER Key momentarily

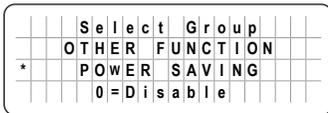

- Screen No. 1 of "Select Parameter, OTHER FUNCTION, *POWER SAVING, 0=Disable" (*Fig 4.4*) will appear as in the left.

4. Press DOWN Key momentarily, (i) 11 times for EVO-1212F / 1212F-HW / 1224F / 1224F-HW / 4248SP or (ii) 12 times for (a) EVO-2212 / 3012 / 2224 / 4024 and (b) EVO-2212E / 3012E / 2224E / 4024E

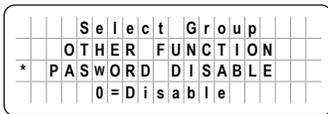

- Screen "Select Parameter, OTHER FUNCTION, * PASSWORD DISABLE, 0=Disable" (*Fig 4.4*) will appear as on the left.

NOTE: Default value is 0=Disable i.e. Disable the command "DISABLE PASSWORD" which means enable password protection.

5. Press ENTER Key momentarily

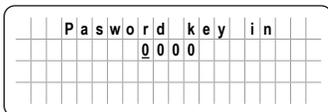

- Password consisting of 4 digits "0000" will be requested as shown on the left (**NOTE:** Password to be entered is 8052). The first digit will have a blinking cursor "_". Use **Up /Down** Keys to scroll to number 8 for the first digit "8" of the password. **Momentarily** press **Enter Key** (*Short* press). Digit 8 will be entered as the first digit of the Password and the blinking cursor will automatically move to the 2nd digit (0) to the right. As the next digit in the Password "8052" is already "0", **momentarily** press **Enter Key** (*Short* press) to enter "0" in the second digit. The blinking cursor will automatically move to the 3rd digit (0). Use **Up / Down** Keys to scroll to number 5 for the 3rd digit "5" of the password "8052" and **momentarily** press **Enter Key** (*Short* press). The blinking cursor will automatically move to the 4th digit (0). Use Up /Down Keys to scroll to number 2 for the 4th digit "2" of the password "8052". Now keep the **Enter Key pressed continuously for longer time** (3 to 4 sec) to write the full password of 4 digits i.e. "8052".

SECTION 4 | Parameter Setup

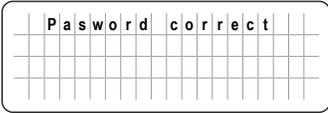

- Flashes twice when Password is correct. (8052)

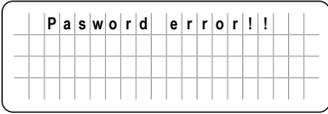

- Flashes twice when Password is NOT correct.

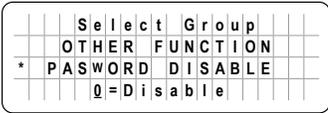

- Screen as on the left will appear with a blinking cursor "_" under "0".

6. Use Up ↑ Key to change 0 to 1.

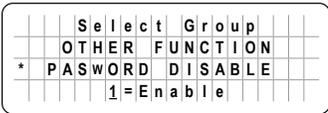

- Screen as on the left will appear. Command will change to 1=Enable with a blinking cursor "_" under "1".

7. Press Enter Key for **longer time** (3 to 4 sec) to write the new selection "1=Enable"

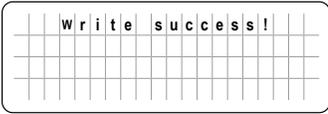

- New selection will be written with the message "Write success!" as shown on the left.

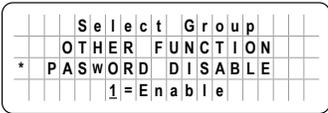

- Screen as on left will appear confirming that the password has been disabled.

8. Press "Back Key" two times to go back to the Operating Mode Screen.

4.4 GROUP 1 PARAMETER SETUP: CHARGE CURVE

4.4.1 Programming Ranges and Default / Factory Preset Values or Parameters Under Group 1 - CHARGE CURVE

Table 4.3 gives details of programming ranges and default values of parameters under Group 1 - "CHARGE CURVE". Refer to Fig 4.2 under Section 4.1.3.1 for the Menu Map for navigating through various parameters under this Group.

SECTION 4 | Parameter Setup

Parameter Setup Screen No. (Column 1)	Parameter (Column 2)	EVO-1212F EVO-1212F-HW (Column 3)	EVO-2212 EVO-2212E (Column 4)	EVO-3012 EVO-3012E (Column 5)	EVO-1224F EVO-1224F-HW (Column 6)	EVO-2224 EVO-2224E (Column 7)	EVO-4024 EVO-4024E (Column 8)	EVO-4248SP (Column 9)
1	"BULK CURRENT" *See Note 1 (Bulk Charge Current "I _o ")	0 – 60A (Default:20A)	0 – 100A (Default:40A)	0 – 130A (Default:40A)	0 – 40A (Default: 20A)	0 – 70A (Default:40A)	0 – 110A (Default:40A)	0 – 60A (Default:20A)
2	"ABSORP VOLTAGE" (Absorption Voltage)	12.00 – 16.00V (Default: 14.40V)			24.00 – 32.00V (Default: 28.80V)			48.00 – 64.00V (Default: 57.60V)
3	"EQUALIZE VOLTAGE" (Equalization Voltage)	14.00 – 16.50V (Default: 14.40V)			28.00 – 33.00V (Default: 28.80V)			56.00 – 66.00V (Default: 57.60V)
4	"FLOAT VOLTAGE" (Float Voltage)	12.00 – 15.00V (Default: 13.50V)			24.00 – 30.00V (Default: 27.00V)			48.00 – 60.00V (Default: 54.00V)
5	"COMPENSATE" (Temperature Compensation)	3mV to 5mV/C/Cell (Default: 4mV/C/Cell)						
6	"BATT OVER VOLT" (Battery Over Voltage Shut Down)	14.00 – 17.50V (Default: 16.00V)			28.00 – 35.00V (Default: 32.00V)			56.00 – 70.00V (Default: 64.00V)
7	"RESET VOLTAGE" (Battery Low Voltage Reset)	12.00 – 17.50V (Default: 14.00V)			24.00 – 35.00V (Default: 28.00V)			48.00 – 70.00V (Default: 56.00V)
8	"LOW VOLT ALARM" (Battery Low Voltage Alarm)	9.50 – 13.50V (Default: 11.00V)			19.00 – 27.00V (Default: 22.00V)			38.00 – 54.00V (Default: 44.00V)
9	"BATT LOW VOLTAGE" (Battery voltage at which inverter shut down/ complete shut down is triggered in conjunction with "LV DETECT TIME" and "LV CUT OFF TIME")	>9.00 – 13.00V (Default: 10.50V)			>18.00 – 24.00V (Default: 21.00V)			>36.00 – 52.00V (Default: 42.00V)
10	"LV DETECT TIME" (Detect time to qualify low battery voltage as "BATT LOW VOLTAGE" condition)	0 – 600 sec (Default: 10 sec)						
11	"LV CUT OFF TIME" (Time in "BATT LOW VOLTAGE" condition to trigger complete shut down)	0 – 7200 sec (Default: 1200 sec)						
12	"EQUALIZE-4STAGES" (4 Stage Charging On/Off)	0=No ; 1=Yes (Default: 0=No)						
13	"MODE"	0 = Normal (Default).....Grid / Generator priority Also called Off-Line Mode 1 = On-Line.....Inverter priority Also called On-Line Mode 2 = Charger Only.....Charging and AC bypass only No inverting						
14	"ONLINE OPTION" (Available only when parameter "MODE" is set to "1=On-Line")	0 = Option 1 (Default); 1 = Option 2						
15	"RESET TO BULK" (Voltage to exit Float Stage to re-charge from Bulk Stage)	10.00 – 13.00V (Default: 12.00V)			20.00 – 26.00V (Default: 24.00V)			40.00 – 52.00V (Default: 48.00V)
16	"GS DETECT TIME"	0 – 600 sec (Default: 10 sec)						
17	"GEN ON TIME"	0 – 240 minute (Default: 60 minute)						
18	"GEN OFF DELAY"	0 – 240 minute (Default: 60 minute)						
19	"ABSORP TIME"	0 – 600 min (Default: 60 min)						
20	"ABSORP EXIT AMPS"	0 – 20 A (Default: 4 A)						
21	"CHARGING PROFILE"	0 = 3 Stage Adaptive (Default) 1 = 3 Stage Type 1 2 = 3 Stage Type 2 3 = 2 Stage Type 1 4 = 2 Stage Type 2 5 = 2 Stage Type 3						
22	"BATTERY TYPE"	0 = Lead Acid (Default) 1 = Lithium						
23	"SAFE CHARGING"	0-300 Min (Default: 0 min)						
24	"EXT. CHARGER"	0 = Affect (Default) 1 = Not affect						

***NOTES**

1. "BULK CURRENT" value may automatically reduce in higher ambient temperatures of around 50°-60° if Power Transformer temperature or Heat Sink temperature exceeds specified limits. See the following for more details:

- (i) Section 4.9.3 in the Owner's Manual for EVO-1212F / 1212F-HW / 1224F / 1224F-HW / EVO-4248SP
- (ii) Section 5.3 in the Owner's Manual for EVO-2212 / 3012 / 2224 / 4024
- (iii) Section 5.3 in the Owner's Manual for EVO-2212E / 3012E / 2224E / 4024E

SECTION 4 | Parameter Setup

4.4.2 Description of Parameters under Group 1 - CHARGE CURVE

4.4.2.1 BULK CURRENT *(Table 4.3, Screen No. 1)*

Parameter "BULK CURRENT" sets the maximum charging current during the Bulk Charging Stage. The *default* value is (a) 20A for EVO-1212F / 1212F-HW, (b) 20A for EVO-1224F / 1224F-HW, (c) 40A for (i) EVO-2212 / EVO-3012 / EVO-2224 / EVO-4024 and (ii) EVO-2212E / EVO-3012E / EVO-2224E / EVO-4024E and (d) 20A for EVO-4248SP.

Normally, Lead Acid batteries should not be charged at very high Bulk Current as this may damage the batteries due to overheating and cell degradation. Normal Bulk Charging Current is in the range of 10% to 20% of the Ah capacity of the battery bank at C/20 Discharge Rate. Lithium Ion Batteries can be charged at much higher Bulk Current as compared to Lead Acid type. Check with the battery manufacturer regarding recommended Bulk Charging Current for your battery bank.



CAUTION WHEN SETTING "BULK CURRENT" FOR MODEL EVO-4248SP!

When the AC input voltage is 120 VAC Single Phase, the Bulk Current setting of Model EVO-4248SP should be reduced to <30A. This will prevent the unit from overheating due to unbalance when charging the battery bank and running pass-through loads from both L1 & L2 legs of 120/240 VAC Split Phase output (See Section 3.6.1.2 of the Owner's Manual for Model EVO-4248SP).



ATTENTION LORS DU RÉGLAGE DU «COURANT EN VRAC» POUR LE MODÈLE EVO-4248SP!

Lorsque la tension d'entrée CA est de 120 VCA monophasé, le réglage du courant de masse du modèle EVO-4248SP doit être réduit à <30A. Cela empêchera l'unité de surchauffer en raison d'un déséquilibre lors de la charge du groupe de batteries et de l'exécution des charges de passage à partir des deux jambes L1 et L2 de la sortie de phase divisée 120/240 VCA (Voir la section 3.6.1.2 du manuel d'utilisation du modèle EVO-4248SP).

SECTION 4 | Parameter Setup



1. In order to protect against over temperature shut down when operating in higher ambient temperatures, the set value of "BULK CURRENT" is automatically reduced as follows based on temperature sensed at the Power Transformer and at the Heat Sink for the Power Mosfets:
 - a) **Models: (i) EVO-2212 / EVO-3012 / EVO-2224 / EVO-4024 and (ii) EVO-2212E / EVO-3012E / EVO-2224E / EVO-4024E**
 - Power Transformer Temperature > 130°C: (i) EVO-2212 / EVO-2212E: Reduce by 4A every 10 sec, (ii) EVO-3012 / EVO-3012E: Reduce by 20A every 10 sec, (iii) EVO-2224 / EVO-2224E: Reduce by 1A every 10 sec, (iv) EVO-4024 / EVO-4024E: Reduce by 5A every 10 sec.
 - Heat Sink Temperature is > 65 °C: (i) EVO-2212 / EVO-2212E: Reduce by 4A every 10 sec, (ii) EVO-3012 / EVO-3012E: Reduce by 20A every 10 sec, (iii) EVO-2224 / EVO-2224E: Reduce by 1A every 10 sec, (iv) EVO-4024 / EVO-4024E: Reduce by 5A every 10 sec.
 - b) **Models EVO-1212F, EVO-1212F-HW, EVO-1224F, EVO-1224F-HW and EVO-4248SP**
 - Power Transformer Temperature > 130°C: Reduce by 0.2% every 20 sec
 - Heat Sink Temperature is > 90 °C: Reduce by 0.2% every 20 sec
2. In case external Solar Charge Controller is also charging the batteries through DC input terminals marked "EXT Charger", the amount of Bulk Charging current produced by the internal Battery Charging Section is adjusted in real time to satisfy the following condition:
 - Internal Bulk Charging Current = Programmed Value of "BULK CURRENT" – External Charging Current

For example, if the "BULK CURRENT" in the EVO-1212F is programmed at say the default value of 20A and the external Solar Charge Controller is generating 15A, the internal Battery Charging Section of EVO-1212F will reduce its current from 20A to 5A so that the net charging current is equal to the programmed "BULK CURRENT" value of 20A.

SECTION 4 | Parameter Setup

4.4.2.1.1 Programming Steps for Parameter "BULK CURRENT"

Any Operating Mode Screen from Fig 3.1 to 3.8

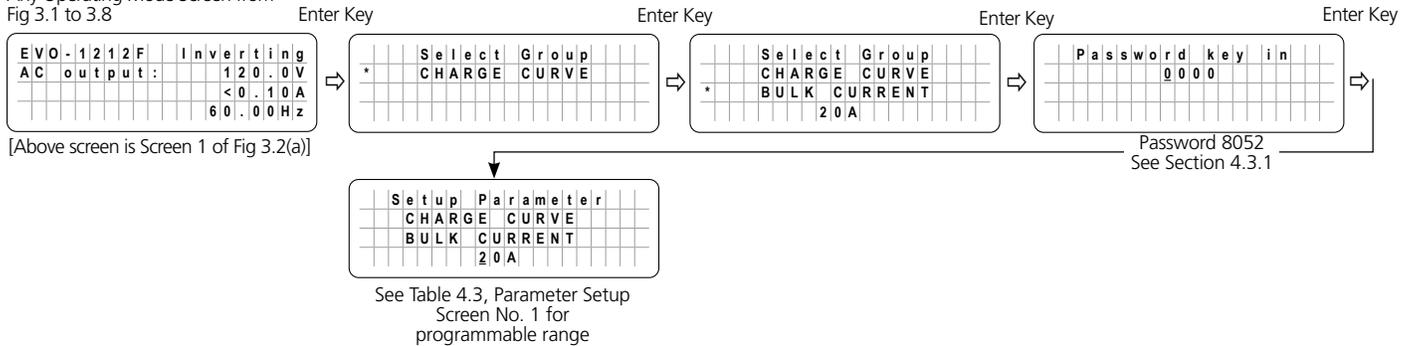

4.4.2.2 ABSORP VOLTAGE (Table 4.3, Screen No. 2)

This sets the charging voltage in the Constant Voltage Absorption Stage.

4.4.2.2.1 Programming Steps for Parameter "ABSORP VOLTAGE"

Any Operating Mode Screen from Fig 3.1 to 3.8

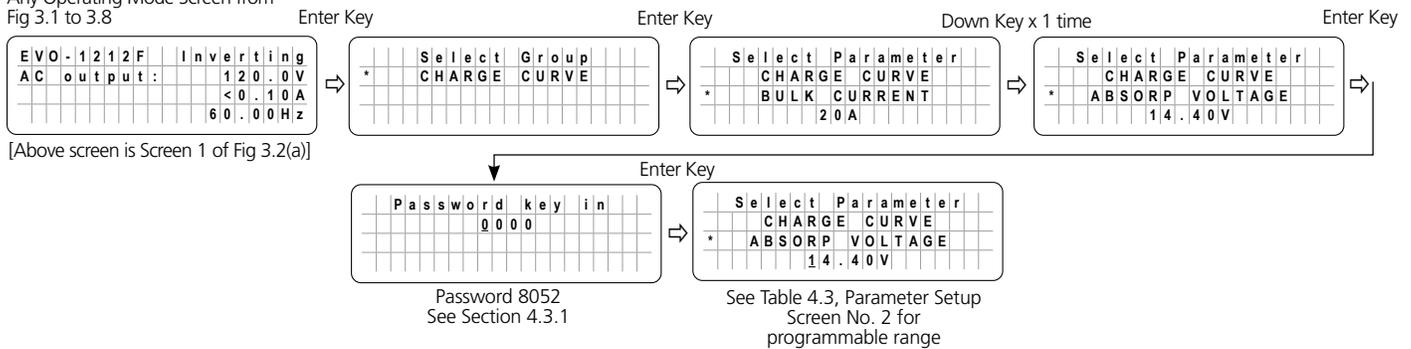

4.4.2.3 EQUALIZE VOLTAGE (Table 4.3, Screen No. 3)

This sets the charging voltage in the Constant Voltage Equalization Stage in the 4-stage Adaptive Charging Profile for Equalization Charging Stage.

4.4.2.3.1 Programming Steps for Parameter "EQUALIZE VOLTAGE"

Any Operating Mode Screen from Fig 3.1 to 3.8

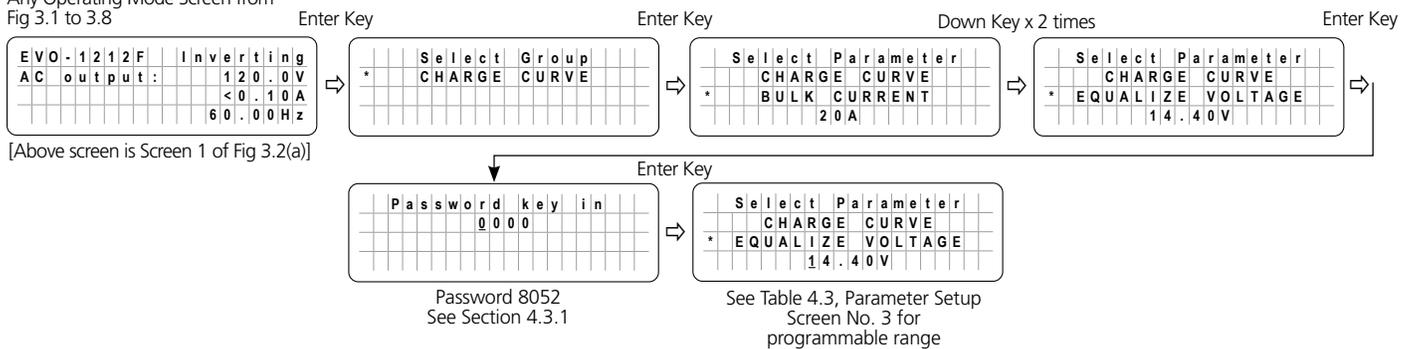

SECTION 4 | Parameter Setup

4.4.2.4 FLOAT VOLTAGE (Table 4.3, Screen No. 4)

This sets the charging voltage in the Constant Voltage Float Stage.

4.4.2.4.1 Programming Steps for Parameter "FLOAT VOLTAGE"

Any Operating Mode Screen from Fig 3.1 to 3.8

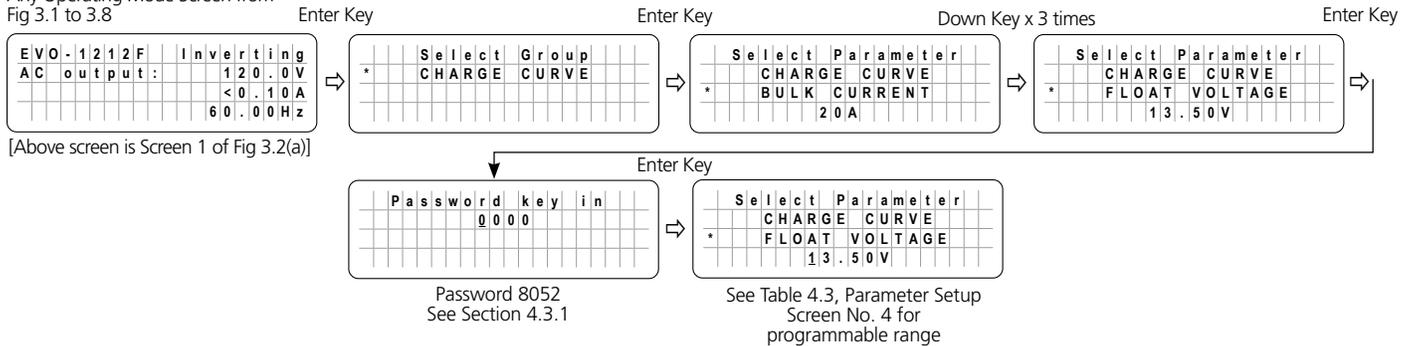

4.4.2.5 COMPENSATE (Table 4.3, Screen No. 5)

This parameter sets the temperature compensation for the battery. The operational range of the EVO™ Inverter/Charger is -20°C to 60°C.

This compensation voltage will affect the Absorption Voltage/Equalize Voltage/Floating Voltage/Batt Over Volt/Restart Voltage/Low Volt Alarm/Batt Low Voltage when the Temperature Sensor is installed on the battery (*see Section 2.5 in the Owner's Manual for Evolution™ Series Inverter/Charger*).



CAUTIONS!

1. Lithium Ion charging does not require temperature compensation. Hence, do not use EVO-BCTS Temperature Sensor when charging Lithium Ion Batteries.
2. Automatic temperature compensation using EVO-BCTS Temperature Sensor is designed for Lead Acid Batteries based on programming parameter "COMPENSATE". When charging Nickel-Zinc (Ni-Zn) batteries, ensure that the value of programming parameter "COMPENSATE" is set based on approximate linear compensation for the particular Ni-Zn battery.



ATTENTIONS!

1. Le chargement au lithium-ion ne nécessite pas de compensation de température. Par conséquent, n'utilisez pas le capteur de température EVO-BCTS lors du chargement de batteries au lithium-ion.
2. Compensation automatique de la température à l'aide d'EVO-BCTS Capteur de température est conçu pour les batteries au plomb basée sur la programmation paramètre "COMPENSATE". Lorsque la charge des batteries Nickel-Zinc (Ni - Zn), s'assurer que la valeur du paramètre de programmation "COMPENSATE" est déterminé en fonction du linéaire approximatif pour l'indemnisation de la batterie Ni - Zn particulier.

SECTION 4 | Parameter Setup

4.4.2.5.1 Programming Steps for Parameter "COMPENSATE"

Any Operating Mode Screen from Fig 3.1 to 3.8

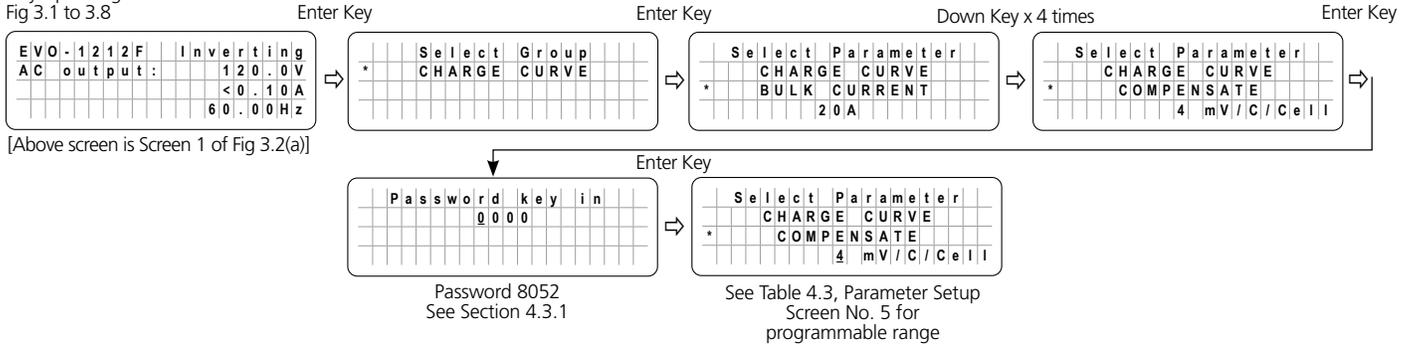

4.4.2.6 BATT OVER VOLT (Table 4.3, Screen No. 6)

This parameter sets the upper battery voltage threshold at which inverting / charging operations are switched OFF to protect the unit against damage due to battery overvoltage:

- AC input is not available and EVO™ Inverter/Charger is operating in Inverting Mode:** When the battery voltage rises to the set upper threshold of "BATT OVER VOLT", the Inverter Section will be shut down and fault message "Battery over voltage!" will be displayed on the LCD screen. The Blue LED marked "Status" will switch OFF and the Red LED marked "Fault" will remain ON steady. The buzzer on EVO™ Inverter/Charger will beep steady. The fault will be cleared automatically when the battery voltage drops to 0.5V below the set upper threshold of "BATT OVER VOLT"
- AC input is available and EVO™ Inverter/Charger is operating in Charging Mode:** When the battery voltage rises to the set upper threshold of "BATT OVER VOLT", the Transfer Relay will be de-energized, charging and pass through will be stopped and PWM drive to the Inverter Section will be switched OFF. Fault message "Battery over voltage!" will be displayed on the LCD screen. The Blue LED marked "Status" will switch OFF and the Red LED marked "Fault" will remain ON steady. The Buzzer on EVO™ Inverter/Charger will beep steady. The fault will be cleared automatically when the battery voltage drops to 0.5V below to the set upper threshold of "BATT OVER VOLT". The unit will start in Inverting Mode, synchronize with the AC input and then, the Transfer Relay will be energized to transfer to AC input at zero crossing. The unit will, thus, resume operation in "Charging Mode".

4.4.2.6.1 Programming Steps for Parameter "BATT OVER VOLT"

Any Operating Mode Screen from Fig 3.1 to 3.8

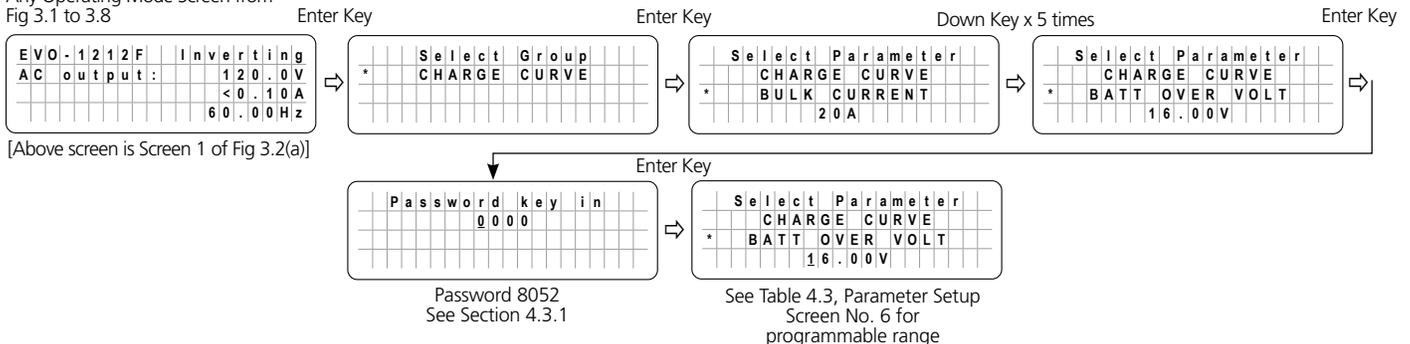

SECTION 4 | Parameter Setup

4.4.2.7 RESET VOLTAGE (Table 4.3, Screen No. 7)

- The inverter will restart when the battery voltage rises to this set value or above after "Battery low voltage!" shutdown occurs (Section 7, Srl. No. 1 of Table 7.1)
- If automatic starting / stopping of Generator is used with RELAY FUNCTION set at "3= Generator 1" (Section 4.8.2.5.2.2), the Relay will turn off when the battery voltage remains at this value or higher for time period equal to "GEN OFF DELAY" (Section 4.4.2.18). Turning Off the Relay will automatically stop the Generator [Refer to Section 4.8.2.5.2.2 for details].

4.4.2.7.1 Programming Steps for Parameter "RESET VOLTAGE"

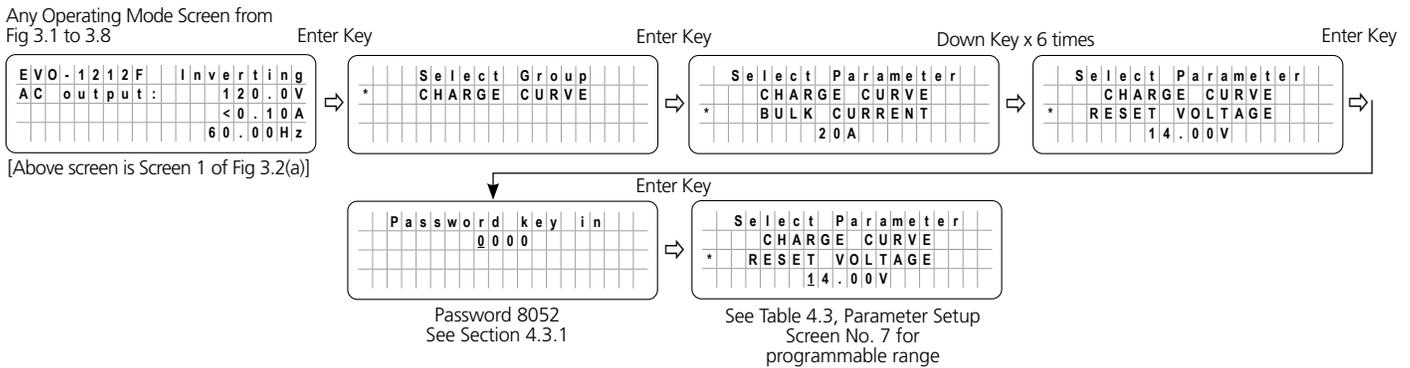

4.4.2.8 LOW VOLT ALARM (Table 4.3, Screen No. 8)

- When inverting, if battery voltage is under the set value of "LOW VOLTAGE ALARM", the Red LED marked "Fault" flashes once per second. The buzzer in EVO™ Inverter/Charger will beep once per second.
- If automatic starting / stopping of Generator is used with "RELAY FUNCTION" programmed at "2=Generator 0" (Section 4.8.2.5.2.1) or "3= Generator 1" (Section 4.8.2.5.2.2) or "4= Generator 2" (Section 4.8.2.5.2.3), the Relay will turn ON if the battery voltage dips to the value of "LOW VOLTAGE ALARM" and remains at this level or lower for time period equal to the value of "GS DETECT TIME" (Section 4.4.2.16). Turning ON of the relay will automatically start the Generator (Refer to Sections 4.8.2.5.2.1 to 3 for details).
- If parameter "MODE" is programmed at "1= Online" (see Section 4.4.2.13) and parameter "ONLINE OPTION" is programmed at 0= Option 1" or "1 = Option 2" (see Section 4.4.2.14), the Transfer Relay will be switched ON if the battery voltage drops to the programmed value of "LOW VOLTAGE ALARM" or lower for a period equal to the parameter "GS DETECT TIME" (Section 4.4.2.16). Switching ON of the Transfer Relay will initiate battery charging and AC pass-through (See Section 4.4.2.14 for details).

4.4.2.8.1 Programming Steps for Parameter "LOW VOLT ALARM"

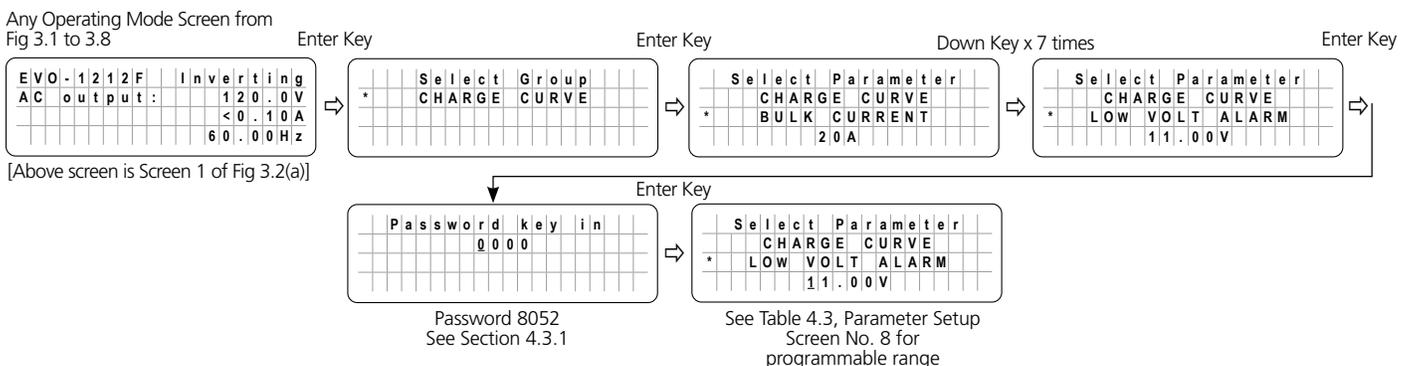

SECTION 4 | Parameter Setup

4.4.2.9 BATT LOW VOLTAGE *(Table 4.3, Screen No. 9)*

This parameter sets the battery low voltage threshold at which the Inverter Section / the complete EVO™ Inverter/Charger will be shut down to protect the battery from deep discharge:

4.4.2.9.1 BATTERY LOW VOLTAGE (Value of parameter LV CUT OFF TIME set from 1 to 7200 sec)

- When the battery voltage drops to the set threshold of “BATT LOW VOLTAGE”, the Red LED marked “Fault” will flash once per second. The buzzer in EVO™ Inverter/Charger will beep once per second. The Inverter Section will continue to operate normally and the Blue LED marked “Status” will continue to be ON steady.
- If the battery voltage stays at or below the above threshold for duration equal to the “LV DETECT TIME” *(Section 4.4.2.10)*, only the Inverter Section will be switched OFF and fault message “Battery low voltage!” *(Table 7.1, Srl. No.1)* will be displayed. The Blue LED marked “Status” will be switched OFF and the Red LED marked “Fault” will remain ON steady. The buzzer in EVO™ Inverter/Charger will beep steady.
- If the batteries are charged by external Solar Charge Controller connected directly to the batteries or through the External Charger Input *(3, 4 in Fig 2.1 in the Owner's Manual for Evolution™ Series Inverter/Chargers)* and the battery voltage recovers to the set “RESET VOLTAGE” *(Section 4.4.2.7)* before the expiry of “LV CUT OFF TIME” *(Section 4.4.2.11)*, while in “Battery low voltage!” fault condition *(Table 7.1, Srl. No.1)*, the Inverter Section will restart and the “Battery low voltage!” fault condition will be cleared.
- While in “Battery low voltage!” fault condition *(Section 7, Table 7.1, Srl. No.1)*, if AC input is made available before the expiry of “LV CUT OFF TIME” *(Section 4.4.2.11)*, the “Battery low voltage!” fault condition will be cleared. The EVO™ Inverter/Charger will restart in Inverter Mode, synchronize with the AC input and then, transfer to the AC input at zero crossing. It will now operate in Charging Mode.
- If the “Battery low voltage!” fault condition is **NOT** reset within the “LV CUT OFF TIME” *(Section 4.4.2.11)*, the EVO™ will be shut down completely after the programmed value of LV CUT OFF TIME has elapsed. *The LCD display / Status LED / Buzzer will be off in this condition.*

4.4.2.9.2 BATT LOW VOLTAGE (Value of parameter “LV CUT OFF TIME” set at 0 sec)

4.4.2.9.2.1 When programming value of parameter “LV CUT OFF TIME” *(Section 4.4.2.11)* is set at 0 sec, “Battery low voltage!” fault condition *(Section 7, Table 7.1, Srl.No.1)* will operate as follows:

- The unit will NOT shut down completely due to “Battery low voltage!” fault condition *(as in Section 4.4.2.9.1)* but will continue to display fault message “Battery low voltage!” after expiry of “LV DETECT TIME” *(Section 4.4.2.10)*.
 - Blue LED marked “Status” *(3 in Fig 1.1)* will be switched off
 - Red LED marked “Fault /Alarm” *(4 in Fig 1.1)* will be ON steady
 - Buzzer in the EVO™ Inverter Charger will beep once at intervals of 1 sec

4.4.2.9.2.2 The unit will automatically switch to “Charging Mode” only under the following conditions:

- a) If qualified AC input is available that is within the limits of voltage *(Sections 4.6 and 4.7)* and frequency *(Section 4.5.2.4 and 4.5.2.6)*
- b) If the battery voltage at the time of qualified AC input availability is higher than “Battery ultra low voltage!” threshold.

SECTION 4 | Parameter Setup

4.4.2.11 LV CUT OFF TIME (Table 4.3, Screen No. 11)

4.4.2.11.1 Value of LV CUT OFF TIME: 1 to 7200 sec

Even when the Inverter Section is shut down due to "Battery low voltage!" fault condition as described at Section 4.4.2.9, there will still be some power drawn from the battery to keep the other circuitry in the EVO™ Inverter/Charger alive so that the inverter can be switched on when the fault gets cleared automatically after the battery has been recharged to the "RESET VOLTAGE" (Section 4.4.2.7) or when AC input voltage is available. However, if the fault is not cleared over a long period of time, the battery may get completely discharged. Hence, a timer is used to record the duration of "Battery low voltage!" condition (Section 4.4.2.9). The EVO™ Inverter/Charger will be completely shut down (LCD Display / LED / Buzzer will be OFF) when the duration of the "Battery low voltage!" fault condition (Section 4.4.2.9) is equal to the "LV CUT OFF TIME".

4.4.2.11.2 Value of LV CUT OFF TIME: 0 sec

4.4.2.11.2.1 When the value of parameter "LV CUT OFF TIME" is set at 0 sec, activation and resetting of "Battery low voltage!" fault condition (Srl. 1, Table 7.1) will be as described in Section 4.4.2.9.2.

4.4.2.11.3 Programming Steps for Parameter "LV CUT OFF TIME"

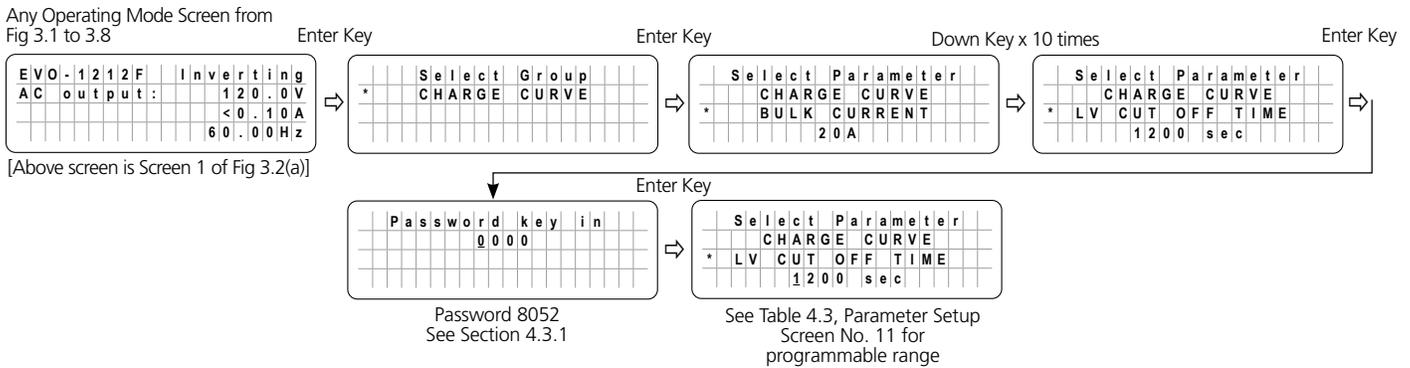

4.4.2.12 EQUALIZE – 4 STAGES (Table 4.3, Screen No. 12)

For background information on 4-Stage Adaptive Charging Profile for Equalization, please refer to Section 5.8 and 5.9 of the separate Owner's Manuals for EVO™ Inverter / Chargers Series. When AC input within the programmed window of voltage and frequency is available, EVO™ will operate as a battery charger and charging will be carried out based on the selected option of parameter "CHARGING PROFILE". Parameter "CHARGING PROFILE" (Section 4.4.2.21) allows option to select from 6 Charging Profiles - 3 profiles of 3-Stage and 2 profiles of 2-Stage charging. Default profile option is "0=3-Stage Adaptive"

4-Stage Adaptive Charging Profile for Equalization can be activated AT ANY TIME through programmable parameter "EQUALIZE-4STAGES" set to "1=Yes". The Default Setting is "0=No" i.e. charging will be carried out as per 3 or 2-Stage profile that has been selected by parameter "CHARGING PROFILE" (Section 4.4.2.21). After the 4-Stage Adaptive Charging Profile for Equalization is completed, parameter "EQUALIZE-4STAGES" resets automatically to the default setting i.e. Option "0=No" and the charging profile reverts to the last stage of the "CHARGING PROFILE" that was active when 4-Stage Adaptive Charging Profile for Equalization was activated. Details are given at Table 4.4:

SECTION 4 | Parameter Setup

TABLE 4.4 CHARGING PROFILE FOR 4-STAGE ADAPTIVE CHARGING FOR EQUALIZATION

Srl No.	Options under Programming Parameter "EQUALIZE-4 STAGES"	Charging Stages	Battery Type / CAUTIONS!
1	EQUALIZE – 4 STAGES 0 = No (Default Setting) 1 = Yes	<ol style="list-style-type: none"> 1. Stage 1 – Bulk Stage <ul style="list-style-type: none"> • Charge at constant current (CC) = the programmed value of parameter "BULK CURRENT" <i>For details of programming range & procedure, refer to Section 4.4.2.1.</i> • Transition to Absorption Stage when voltage rises to the set value for programming parameter "ABSORP VOLTAGE" <i>For details of programming range & procedure, refer to Section 4.4.2.2.</i> 2. Stage 2 - Absorption Stage <ul style="list-style-type: none"> • Charge at constant voltage (CV) = the programmed value for parameter "ABSORP VOLTAGE". <i>For details of programming range & procedure, refer to Section 4.4.2.2.</i> • Adaptive Time Algorithm: Time in Absorption Stage is computed automatically based on time in Bulk Stage • Transition to Equalization Stage thereafter. 3. Stage 3 - Equalization Stage <ul style="list-style-type: none"> • Charge at constant voltage (CV) = the programmed value of parameter "EQUALIZE VOLTAGE". <i>For details of programming range & procedure, refer to Section 4.4.2.3.</i> • Adaptive Time Algorithm: Time in Equalization Stage is computed automatically based on time in Bulk Stage. • Transition to Float Stage thereafter. 4. Stage 4 - This stage will be the same as the last Stage of Charging Profile from where Equalization was started. 	– Lead Acid: Flooded only  CAUTIONS! <ol style="list-style-type: none"> 1. Equalize Flooded Lead Acid Batteries only. Sealed AGM / Gel Cell types of batteries are NOT equalized 2. <i>Refer to Section 5.8.2 and Fig 5.2 of the Owner's Manuals for EVO™ Inverter / Chargers Series</i> 3. The Adaptive Charging Algorithm measures the Bulk Stage Time (T0) to automatically compute Absorption Stage Time (T1') and Equalization Stage Time (T2). This algorithm is fully effective only when there are no other external DC loads being supplied by the battery that may divert full or part of the BULK CURRENT resulting in undesired increase in Bulk Stage Time "(T0)" and consequently, undesired increase of Absorption Stage Time (T1') and Equalization Stage Time (T2). <i>Hence, disconnect all other external DC loads on the battery during the equalization cycle.</i>
 INFO For complete understanding of the above 4 Stages of Charging and the associated Charging Curves, please refer to Sections 5.8 and 5.9 of the following Owner's Manuals: (i) Owner's Manual for EVO-1212F / 1212F-HW / 1224F / 1224F-HW (ii) Owner's Manual for EVO-2212 / 3012 / 2224 / 4024 (iv) Owner's Manual for EVO-2212E / 3012E / 2224E / 4024E (iv) Owner's Manual for EVO-4248SP			 ATTENTIONS! <ol style="list-style-type: none"> 1. Égaliser les batteries au plomb inondées seulement. Les batteries scellées de type AGM / cellules au gel ne sont pas égalisées. 2. <i>Se reporter à la section 5.8.2 et figure 5.2 du manuels pour onduleurs / chargeurs de la série EVO.</i> 3. L'algorithme de charge adaptative l'essentiel des mesures de phase (T0) pour calculer automatiquement l'étape d'Absorption Temps (T1') et de la péréquation, le temps (T2). Cet algorithme n'est pleinement efficace que lorsqu'il n'y a pas d'autres charges c.c. externe alimenté par la batterie qui peut détourner tout ou partie de l'ACTUEL EN VRAC résultant en une augmentation indésirable en vrac temps Étape "(T0)" et par conséquent, augmentation indésirable de l'étape d'Absorption Temps (T1') et de la péréquation le temps (T2). <i>Par conséquent, déconnectez toutes les autres charges CC externes sur la batterie pendant le cycle d'égalisation.</i>

SECTION 4 | Parameter Setup

4.4.2.12.1 Programming Steps for Parameter "EQUALIZE-4STAGES"

Any Operating Mode Screen from Fig 3.1 to 3.8

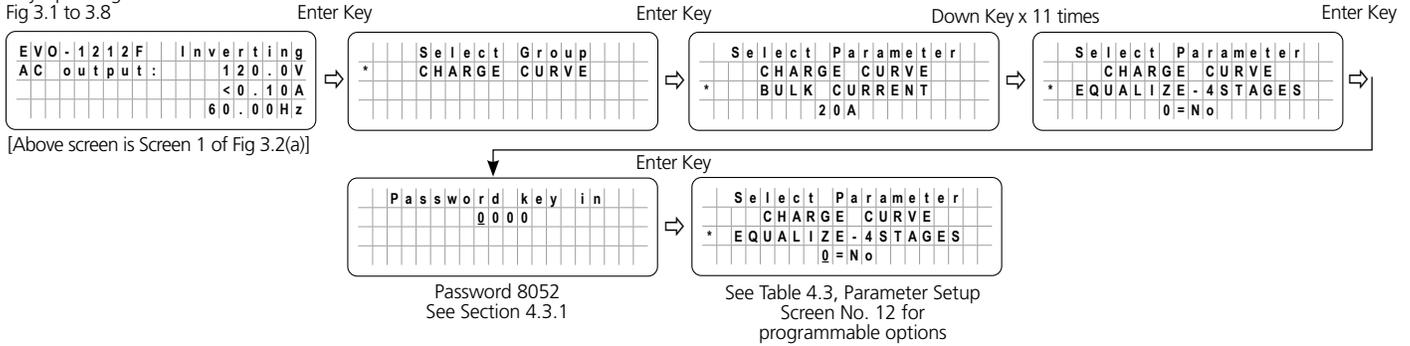

4.4.2.13 MODE (Table 4.3, Screen No. 13)

Under Parameter "MODE" Menu, the following 3 options can be programmed:

- Option "0=Normal" (*Also called "Offline Mode" with Grid/ Generator priority. This is the Default option*)
- Option "1=Online" (*Also called "Online Mode" with Inverter priority*)
- Option "2=Charger Only" (*explained further at Section 4.4.2.13.1*)

For more information on the applications of parameter "MODE" and its 3 options, please refer to the following sections:

- Section 4.6.5 of Owners Manual for Models EVO-1212F / 1212F-HW / 1224F / 1224F-HW
- Section 4.8.5 of Owners Manual for Models (i) EVO-2212 / 3012 / 2224 / 4024 and (ii) EVO-2212E / 3012E / 2224E / 4024E
- Section 4.6.5.of Owners Manual for Models EVO-4248SP

4.4.2.13.1 Charger Only Mode (Table 4.3, Screen No. 13)

Under Parameter "MODE" (*Section 4.4.2.13*), 3 options can be programmed: "0=Normal" (Off-line Mode) or, "1=Online" or, "2=Charger Only".

When "Charger Only" Mode is selected (*Option "2=Charger Only"*), EVO™ will charge the batteries and pass through the AC input power to the loads as long as AC input is available.

- Charging Mode Screens will be displayed as follows:
 - For EVO-1212F / 1212F-HW / 1224F / 1224F-HW: Menu Map at Fig 3.3(a)
 - For EVO-2212 / 2212E / 3012 / 3012E / 2224 / 2224E / 4024 / 4024E: Menu Map at Fig 3.3(b)
 - For EVO-4248SP: Menu Map at Fig 3.3(c)

Extract of Screen No.1 for EVO-1212F is shown below as an example.

EVO-1212F						Charging
0-Bulk Stage						
Batt:	12.00V		100.0A			
External:			0.0A			

When the AC input fails, the Inverter Section will NOT be activated and the AC side loads will lose AC power. The EVO™ will internally operate in *Standby Mode* as long as AC input power is NOT available.

SECTION 4 | Parameter Setup

- Standby Mode Screens will be displayed as follows:
 - For EVO-1212F / 1212F-HW / 1224F / 1224F-HW: Menu Map at Fig 3.1(a)
 - For EVO-2212 / 2212E / 3012 / 3012E / 2224 / 2224E / 4024 / 4024E: Menu Map at Fig 3.1(b)
 - For EVO-4248SP: Menu Map at Fig 3.1(c)
- During the period when AC input is not available "Chgr Only" Mode screens will be displayed as follows:
 - EVO-1212F / EVO-1212F-HW / EVO-1224F / EVO-1224F-HW: Fig 3.6(a)
 - (i) EVO-2212 / EVO-3012 / EVO-2224 / EVO-4024 and (ii) EVO-2212E / EVO-3012E / EVO-2224E / EVO-4024E: Fig 3.6(b)
 - EVO-4248SP: Fig 3.6(c)

Extract for Screen No. 1 for EVO-1212F is shown below as an example:

EVO-1212F	Chgr	Only	
Inverter	Off		
Batt:	12.00V	0.0A	
External		0.0A	

- If attempt is made to exit Standby Mode by momentarily pressing the On/Off Key, the following message will be seen for some time and the screen will revert back to "Chgr Only" Mode Screen

Charger	Only		
Inverter	Off		

4.4.2.13.2 Programming Steps for Parameter "MODE"

Any Operating Mode Screen from Fig 3.1 to 3.8

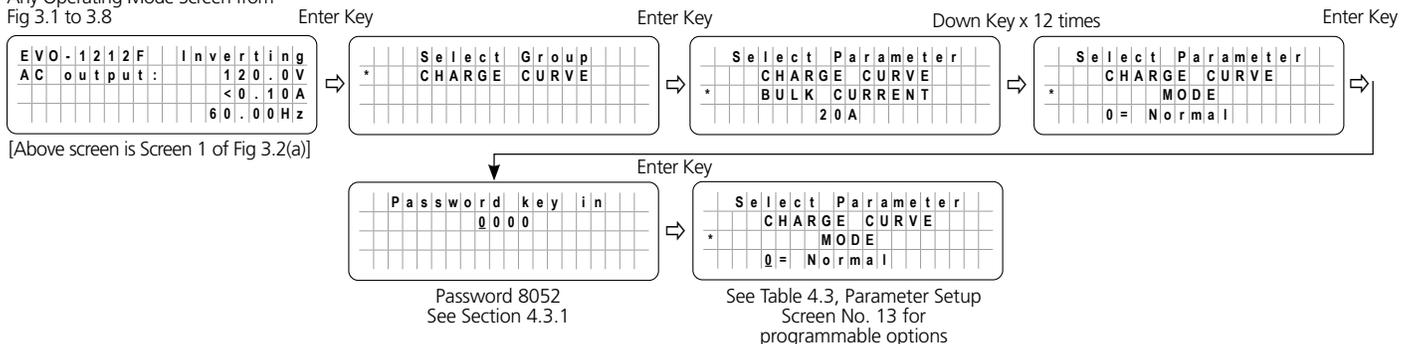

4.4.2.14 ONLINE OPTION (Table 4.3, Screen No. 14)

This setting is effective only when Online Mode is selected (Parameter "MODE" is set at option "1=On-Line". See section 4.4.2.13). The default setting is: 0=Option 1. Programming steps are given below.

SECTION 4 | Parameter Setup

1= Option 2:

- The Transfer Relay will be switched ON (energized) if the battery voltage drops to "LOW VOLT ALARM" (Section 4.4.2.8), or lower for sustained period = "GS DETECT TIME" (Section 4.4.2.16). The EVO™ will change over to "Charging Mode" and qualified AC input from the Grid will be passed through to the AC Output and at the same time, the Internal AC Charger will start charging the battery. If an external Solar Charge Controller is also connected to the External Charging Terminals (3 and 4, Fig 2.1 in Owner's Manuals for Evolution™ Series Inverter/Chargers), the internal AC Charger will limit the charging current to a value = (Programmed Value of Bulk Current – Value of Current fed from the external Solar Charge Controller).
- Charging will proceed as per the Charging Profile selected through parameter "CHARGING PROFILE" (Section 4.4.2.21)
- The Transfer Relay will be switched OFF (de-energized) after the programmed value of "GEN OFF DELAY" (Section 4.4.2.18) counted from the time the battery voltage rises to the programmed value of "RESET VOLTAGE" (Section 4.4.2.7). The unit will exit "Charging Mode" and revert to "Inverting" Mode.

4.4.2.15 RESET TO BULK (Table 4.3, Parameter Setup Screen No. 15)

Refer to Table 4.3, Screen No. 15

Further, refer to the description of 6 types of charging profiles under parameter "CHARGING PROFILE" (Section 4.2.2.21).

Parameter "RESET TO BULK" sets the value of battery voltage at which the charger will terminate the current charging stage of the selected "CHARGING PROFILE" & restart charging from the beginning i.e. from the first "BULK STAGE".

4.4.2.15.1 Programming Steps for Parameter "RESET TO BULK"

Any Operating Mode Screen from Fig 3.1 to 3.8

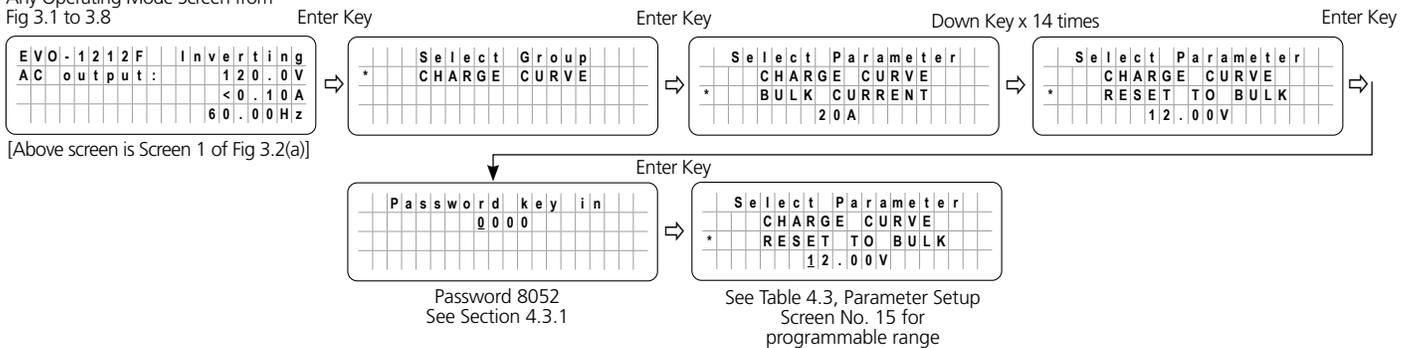

4.4.2.16 GS DETECT TIME (Table 4.3, Parameter Setup Screen No. 16)

This parameter is a Programmable Timer (0-600sec; Default: 10 sec). The Timer sets the duration the battery voltage has to remain at threshold of "LOW VOLT ALARM" condition (Section 4.4.2.8), or lower before the following actions are initiated:

- **Automatic Starting and Stopping of Generator:** Switching ON (energizing) the Status Relay to initiate Generator starting (See Sections 4.8.2.5.2.1 to 4.8.2.5.2.3).
- **On-Line Mode:** Switching ON of the Transfer Relay to transfer from "Inverting" Mode to "Charging" Mode (see Section 4.4.2.14).

SECTION 4 | Parameter Setup

4.4.2.16.1 Programming Steps for Parameter "GS DETECT TIME"

Any Operating Mode Screen from Fig 3.1 to 3.8

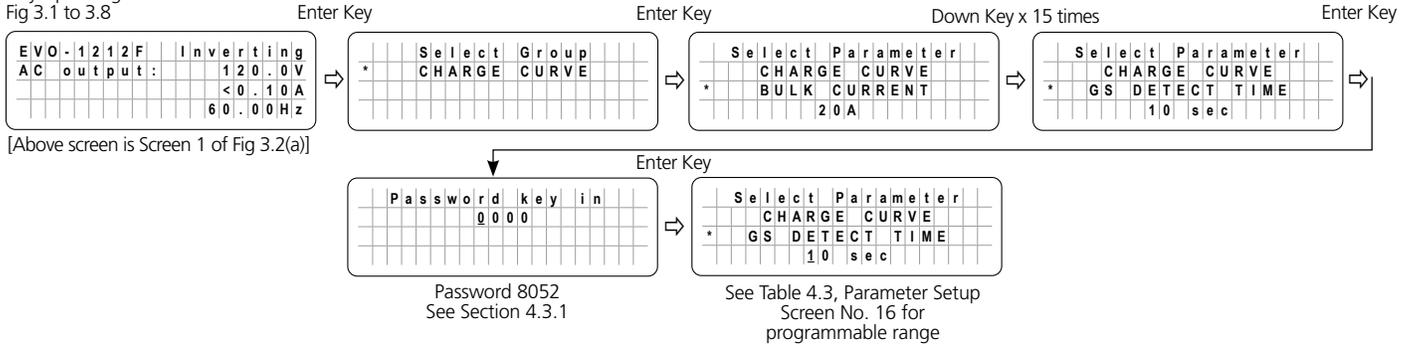

4.4.2.17 GEN ON TIME (Table 4.3, Parameter Setup Screen No. 17)

This parameter is a Programmable Timer (0-240min; Default: 60 min) that is used for programming Automatic Starting and Stopping of Generator [Section 4.8.2.5.2.3]. The Timer sets the duration the Generator will remain ON from the time the Status Relay has been switched ON (energized). The Status Relay will switch ON (energize) and start the Generator if the battery voltage remains at threshold of "LOW VOLT ALARM" (Section 4.4.2.8), or lower for continuous period = "GS DETECT TIME" (Section 4.4.2.16).

4.4.2.17.1 Programming Steps for Parameter "GEN ON TIME"

Any Operating Mode Screen from Fig 3.1 to 3.8

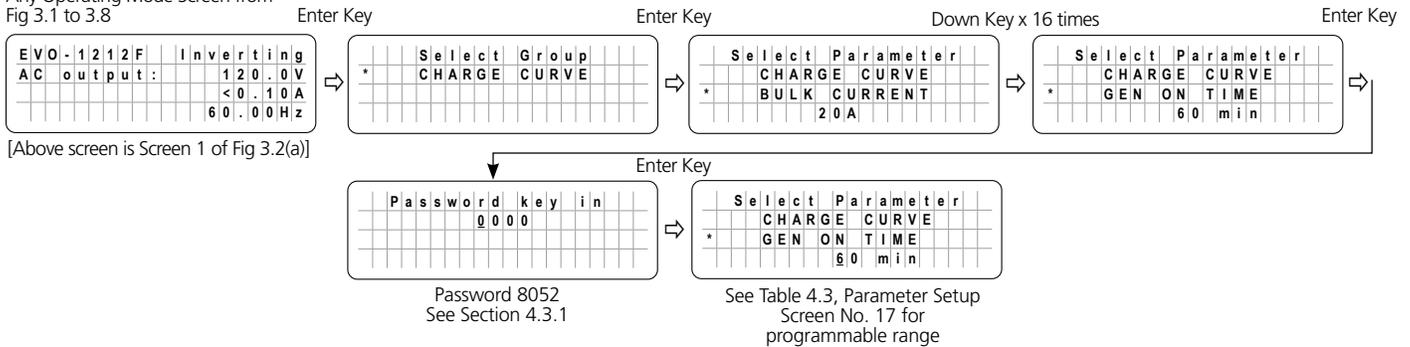

4.4.2.18 GEN OFF DELAY (Table 4.3, Parameter Setup Screen No. 18)

This parameter is a Programmable Timer (0-240min; Default: 60 min) that is used for the following:

- **Programming Automatic Starting and Stopping of Generator (Section 4.8.2.5.2.2):** The Timer sets the time period the batteries are required to remain charged at the desired programmed level of voltage = "RESET VOLTAGE" (Section 4.4.2.7), or higher before the Status Relay is switched OFF (de-energized) to stop the Generator
- **Programming Option "1=Option 2" in "ONLINE OPTION" (Section 4.4.2.14):** The Timer sets the time period the batteries are required to remain charged at the desired programmed level of voltage = "RESET VOLTAGE" (Section 4.4.2.7), or higher before the Transfer Relay is switched OFF (de-energized) to exit "Charging" Mode and revert to "Inverting" Mode.

SECTION 4 | Parameter Setup

4.4.2.20.1 Programming Steps for Parameter "ABSORP EXIT AMPS"

Any Operating Mode Screen from Fig 3.1 to 3.8

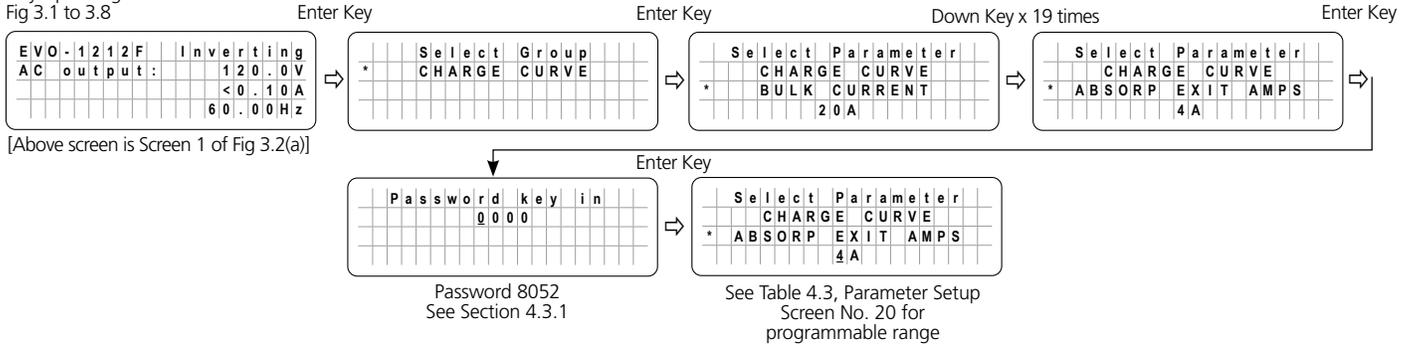

4.4.2.21 CHARGING PROFILE (Table 4.3, Parameter Setup Screen No. 21)

Parameter "CHARGING PROFILE" provides 6 options for Charging Profiles that are designed to cover various charging requirements for Lead Acid, Nickel-Zinc (Ni-Zn) and Lithium Ion Batteries.



INFO

7th Charging Profile i.e. 4-Stage Adaptive Charging Profile for Equalization is also available and can be activated at any time during charging taking place under 1 of the 6 Charging Profile options given at Table 4.5. *Procedure to activate 4-Stage Adaptive Charging Profile for Equalization is described under programming parameter "EQUALIZE- 4 STAGES" at Section 4.4.2.12*

The 6 options under parameter "CHARGING PROFILE" are as follows:

- 0 = 3 Stage Adaptive (Default)
- 1 = 3 Stage Type 1
- 2 = 3 Stage Type 2
- 3 = 2 Stage Type 1
- 4 = 2 Stage Type 2
- 5 = 2 Stage Type 3

NOTE: 3-Stage Adaptive Charging Profile option "0 = 3 Stage Adaptive (*Shown as "0=3 Stg Adaptive" in the programming screen*)" is the default charging profile applicable for Lead Acid Batteries

Details of the 6 programmable charging profiles under programming parameter "CHARGING PROFILE" are given in TABLE 4.5.



Some Battery Management Systems (BMS) for Lithium Ion Batteries may come with protections against over-charge / over-discharge / over-temperature that will require control over charging and discharging of the Lithium Ion battery. For this, any of Pins 1/2/3/4 and 5/6/7/8 of the RJ-45 Jack marked "Battery Temp Sensor" on the front panel of the EVO™ Inverter/Charger (6, Fig 2.1 of Owner's Manual for EVO™ Inverter/Chargers) may be used to feed potential free contact closing signal from the BMS to "Stop Charging" or "Stop Inverting" (Refer to Section 4.4.2.22.2 for details)



Certains systèmes de gestion de batterie (BMS) pour batteries au lithium-ion peuvent être dotés de protections contre la surcharge / sur-décharge / surchauffe qui nécessiteront un contrôle de la charge et de la décharge de la batterie au lithium-ion. Pour cela, l'un des broches 1/2/3/4 et 5/6/7/8 de la prise RJ-45 marquée "Battery Temp Sensor" sur le panneau avant de l'onduleur / chargeur EVO™ (6, Fig 2.1 of Owner's Manuel pour les onduleurs / chargeurs EVO) peut être utilisé pour alimenter le signal de fermeture de contact libre de potentiel du système de management jusqu'à "Stop Charging" ou "Stop Inverting" (Voir la section 4.4.2.22.2 pour plus de détails)

SECTION 4 | Parameter Setup

TABLE 4.5 PARAMETER "CHARGING PROFILE" - OPTIONS FOR 3-STAGE / 2-STAGE CHARGING			
Srl No.	Options under Programming Parameter "CHARGING PROFILE"	Charging Stages	Battery Type
1	<p>0 = 3 Stage Adaptive (Shown as "0=3 Stg Adaptive" in the programming screen)</p> <p>NOTES:</p> <ol style="list-style-type: none"> This is the default setting This is a 3-Stage, Adaptive Profile with "Adaptive Time Algorithm" for the Absorption Stage (For details, refer to Section 5.7.2 of the attached Owner's Manual for EVO-1212F/1212F-HW/1224F/1224F-HW) 	<ol style="list-style-type: none"> Stage 1 – Bulk Stage (For details, see Section 5.7.1.1 of the Owner's Manuals for EVO™ Series Inverter/Chargers): <ul style="list-style-type: none"> Charge at constant current = the programmed value of parameter "BULK CURRENT" (For details of programming range & procedure, refer to Section 4.4.2.1) Transition to Absorption Stage when voltage rises to the set value for programming parameter "ABSORP VOLTAGE" (For details of programming range & procedure, refer to Section 4.4.2.2) Stage 2 - Absorption Stage (For details, see Section 5.7.2 of the Owner's Manuals for EVO™ Series Inverter/Chargers): <ul style="list-style-type: none"> Charge at constant voltage = the programmed value for parameter "ABSORP VOLTAGE". (For details of programming range & procedure, refer to Section 4.4.2.2) Adaptive Time Algorithm: Time in Absorption Stage is computed automatically based on time in Bulk Stage (For details, refer to Section 5.7.2 of the Owner's Manual for EVO-1212F/1212F-HW/1224F/1224F-HW) Transition to Float Stage thereafter. Stage 3 - Float Stage (For details, see Section 5.7.3 of the Owner's Manuals for EVO™ Series Inverter / Chargers): <ul style="list-style-type: none"> Charge at constant voltage = the programmed value for parameter "FLOAT VOLTAGE". (For details of programming range & procedure, refer to Section 4.4.2.4) Reset to Bulk Stage under the following conditions: <ol style="list-style-type: none"> If the AC input fails or is switched off and is restored subsequently. If battery voltage falls to the programmed value of parameter "RESET TO BULK". (For details of programming range & procedure, refer to Section 4.4.2.15). If the charger remains in the Float Stage for 10 days 	<ul style="list-style-type: none"> Lead Acid: Flooded and sealed – AGM/ Gel Cell ENSURE that there are no other DC load(s) on the batteries. Load(s) on the battery may drain full or part of the charging current and will upset the "Adaptive Time Algorithm" for Absorption Stage time
2	1=3Stage Type1	<ol style="list-style-type: none"> Stage 1 – Bulk Stage (For details, see Section 5.7.1.1 of the Owner's Manuals for EVO™ Series Inverter/Chargers): <ul style="list-style-type: none"> Charge at constant current = the programmed value of parameter "BULK CURRENT" (For details of programming range & procedure, refer to Section 4.4.2.1) Transition to Absorption Stage when voltage rises to the set value for programming parameter "ABSORP VOLTAGE" (For details of programming range & procedure, refer to Section 4.4.2.2) Stage 2 - Absorption Stage (For details, see Section 5.7.2 of the Owner's Manuals for EVO™ Series Inverter / Chargers): <ul style="list-style-type: none"> Charge at constant voltage (CV) = the programmed value for parameter "ABSORP VOLTAGE". (For details of programming range & procedure, refer to Section 4.4.2.2) Remain in Absorption Stage for time duration = programmed value of parameter "ABSORP TIME" (For details of programming range & procedure, refer to Section 4.4.2.19) Transition to Float Stage thereafter. Stage 3 - Float Stage (For details, see Section 5.7.3 of the Owner's Manuals for EVO™ Series Inverter / Chargers): <ul style="list-style-type: none"> Charge at constant voltage = the programmed value of parameter "FLOAT VOLTAGE". (For details of programming range & procedure, refer to Section 4.4.2.4) Reset to Bulk Stage under the following conditions: <ol style="list-style-type: none"> If the AC input fails or is switched off and is restored subsequently. If battery voltage falls to the programmed value of parameter "RESET TO BULK". (For details of programming range & procedure, refer to Section 4.4.2.15). If the charger remains in the Float Stage for 10 days 	<ul style="list-style-type: none"> Lead Acid: Flooded and sealed – AGM/ Gel Cell Lithium (For details, see Section 5.11 of Owner's Manuals for EVO™ Series Inverter/Chargers)

SECTION 4 | Parameter Setup

TABLE 4.5 (Continued) PARAMETER "CHARGING PROFILE" - OPTIONS FOR 3-STAGE / 2-STAGE CHARGING			
Srl No.	Options under Programming Parameter "CHARGING PROFILE"	Charging Stages	Battery Type
3	2=3Stage Type2	<p>1. Stage 1 – Bulk Stage (For details, see Section 5.7.1.1 of the Owner's Manual for <i>EVO™ Inverter/Charger</i>):</p> <ul style="list-style-type: none"> Charge at constant current = the programmed value of parameter "BULK CURRENT" (For details of programming range & procedure, refer to Section 4.4.2.1) Transition to Absorption Stage when voltage rises to the set value for programming parameter "ABSORP VOLTAGE" (For details of programming range & procedure, refer to Section 4.4.2.2) <p>2. Stage 2 - Absorption Stage (For details, see Section 5.7.2 of the Owner's Manual for <i>EVO™ Inverter/Charger</i>):</p> <ul style="list-style-type: none"> Charge at constant voltage = the programmed value for parameter "ABSORP VOLTAGE". (For details of programming range & procedure, refer to Section 4.4.2.2) Remain in Absorption Stage till the current reduces to value = the programmed value of parameter "ABSORP EXIT AMPS" (For details of programming range & procedure, refer to Section 4.4.2.20) Transition to Float Stage thereafter. <p>3. Stage 3 - Float Stage (For details, see Section 5.7.3 of the Owner's Manual for <i>EVO™ Inverter/Charger</i>):</p> <ul style="list-style-type: none"> Charge at constant voltage = the programmed value of parameter "FLOAT VOLTAGE". (For details of programming range & procedure, refer to Section 4.4.2.4) Reset to Bulk Stage under the following conditions: <ul style="list-style-type: none"> i. If the AC input fails or is switched off and is restored subsequently. ii. If battery voltage falls to the programmed value of parameter "RESET TO BULK". (For details of programming range & procedure, refer to Section 4.4.2.15). iii. If the charger remains in the Float Stage for 10 days 	<ul style="list-style-type: none"> – Lead Acid: Flooded and Sealed – AGM/ Gel Cell – Lithium (For details, see Section 5.11 of <i>Owner's Manuals for EVO™ Series Inverter/Charger</i>)
4	3=2Stage Type1	<p>1. Stage 1 – Bulk Stage (For details, see Section 5.7.1.1 of the Owner's Manual for <i>EVO™ Inverter/Charger</i>):</p> <ul style="list-style-type: none"> Charge at constant current = the programmed value of parameter "BULK CURRENT" (For details of programming range & procedure, refer to Section 4.4.2.1) Transition to Absorption Stage when voltage rises to the set value for programming parameter "ABSORP VOLTAGE" (For details of programming range & procedure, refer to Section 4.4.2.2) <p>2. Stage 2 - Absorption Stage (For details, see Section 5.7.2 of the Owner's Manual for <i>EVO™ Inverter/Charger</i>):</p> <ul style="list-style-type: none"> Charge at constant voltage = the programmed value for parameter "ABSORP VOLTAGE". (For details of programming range & procedure, refer to Section 4.4.2.2) Remain in Absorption Stage till the time in Absorption Stage is = the programmed value of parameter "ABSORP TIME" (For details of programming range & procedure, refer to Section 4.4.2.19) Switch off charging after expiry of programmed value of parameter "ABSORP TIME" (For details of programming range & procedure, refer to Section 4.4.2.19) Reset to Bulk Stage under the following conditions: <ul style="list-style-type: none"> i. If the AC input from the Grid/Generator is disconnected and is reconnected. ii. If battery voltage falls to the programmed value of parameter "RESET TO BULK". (For details of programming range & procedure, refer to Section 4.4.2.15). 	<ul style="list-style-type: none"> – Lithium (For details, see Section 5.11 of <i>Owner's Manuals for EVO™ Series Inverter/Charger</i>): – Nickel Zinc (For details, see Section 5.10 of <i>Owner's Manuals for EVO™ Series Inverter/Charger</i>)

SECTION 4 | Parameter Setup

4.4.2.22 BATTERY TYPE *(Table 4.3, Parameter Setup Screen No. 22)*

4.4.2.22.1 General Information

Parameter "BATTERY TYPE" is used to change the functionality of RJ-45 Jack marked "Battery Temp. Sensor" on the front panel of EVO™ *(6, Fig 2.1 in the Owner's Manuals for EVO™ Inverter/Chargers)*. The following 2 programming options are available:

a) **Option 1 - "0=Lead Acid" (Default setting):** With this default setting, the RJ-45 Jack will be set to accept input from the Battery Temperature Sensor EVO-BCTS *(Fig 2.5(a) in the Owner's Manuals for EVO™ Series Inverter/Chargers)* when Lead Acid or Nickel-Zinc (Ni-Zn) batteries are being used. Input from the Battery Temperature Sensor will be used to compensate the charging voltages based on the temperature of the Lead Acid or Nickel-Zinc (Ni-Zn) batteries. *Please refer to Section 5.5 of the Owner's Manuals for EVO™ Inverter/Chargers for more details on temperature compensation for Lead Acid and Nickel-Zinc (Ni-Zn) batteries*

b) **Option 2 - "1=Lithium Ion":** With this setting, the RJ-45 Jack will be programmed to receive and process protection control signals "Stop Charging" or "Stop Inverting" from Lithium Battery Management System (BMS). *Application of this setting is explained at Section 4.4.2.22.2 below*

4.4.2.22.2 Stop Charging" and "Stop Inverting" Control by Lithium Ion Battery Management System (BMS)

For protection against over-voltage / over-temperature / over-discharge, Lithium Ion Battery Management Systems (BMS) will normally have capability of providing potential free relay contact closure signal that could be fed to Inverter Charger to stop charging or stop inverting. For this, the BMS will normally use miniature, Normally Open *(1-Form-A)*, Open Drain Opto-Isolated DC Solid-State Relay *(SSR)*. The Solid-State Relay output terminals in the BMS are normally marked "+" *(Drain of Mosfet Switch)* and "-" *(Source of Mosfet Switch)*. Example of this type of relay is IXYS Part No. "CPC1002N" (60V, 700mA rating).

The following 2 types of signals are normally used by the BMS for on/off control of charging and inverting operation of the Inverter-Charger:

- **"Stop Charging" Signal:** In case of (i) over voltage of individual cell / overall battery pack, or (ii) over temperature of individual cell or overall battery pack, the signal will be "enabled" and Solid-State Relay *(SSR)* contacts will close *[Drain (+) and Source (-) Terminals will be shorted]*.
- **"Stop Inverting" Signal:** In case of deep discharge of the battery to the level of Low Battery Cut Off Voltage, the signal will be "enabled" and the Solid-State Relay *(SSR)* contacts will close *(Drain (+) and Source (-) Terminals will be shorted)*.

If the above two protection functions of the BMS i.e. *"Stop Charging"* and *"Stop Inverting"* are to be used for on/ off control of charging and inverting operations of EVO™ Inverter/Charger, the following actions will be required to be undertaken:

- a) Programming parameter **"BATTERY TYPE"** must be changed from Option 1 - "0=Lead Acid" (Default setting) to Option 2 - "1=Lithium" *(see Section 4.4.2.21 above)*. With this setting, the function of front panel RJ-45 Jack marked "Battery Temp. Sensor: *(6, Fig 2.1 in the Owner's Manuals for EVO™ Series Inverter/Chargers)* will change from accepting and processing battery temperature signal from the Battery Temperature Sensor EVO-BCTS to accepting and processing potential free relay contact closure signal from the Solid-State Relay *(SSR)* from the BMS to stop charging /inverting.

SECTION 4 | Parameter Setup

b) Wiring Connection: Output from the Solid-State Relay (SSR) Terminals on the Lithium Battery BMS should be wired to the RJ-45 Jack marked "Battery Temp. Sensor" (6, Fig 2.1 in the Owner's Manuals for EVO™ Series Inverter/Chargers) as follows:

- Connect terminal marked "+" on the SSR (*Drain of Mosfet switch inside SSR*) to any of pins 1/2/3/4 of RJ-45 Jack (*Pinout shown below*)
- Connect terminal marked "-" on the SSR (*Source of Mosfet switch inside SSR*) to any of pins 5/6/7/8 of RJ-45 Jack (*Pinout shown below*)

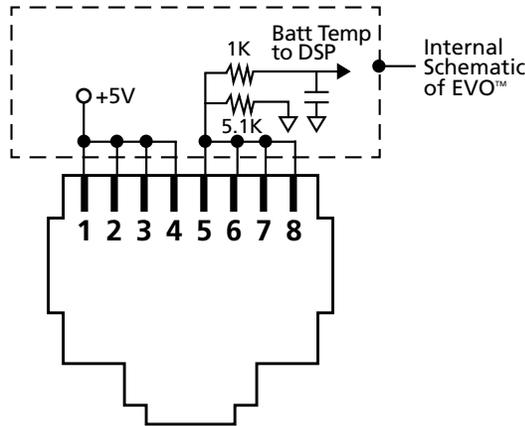

Pinout of RJ-45 Jack marked "Battery Temp Sensor" on the Front Panel of EVO™ Inverter/Charger
(6, Fig 2.1 in the Owner's Manuals for EVO™ Inverter/Chargers)

When the Drain-Source terminals of the BMS close, Pins 1/2/3/4 and 5/6/7/8 of RJ-45 Jack will be shorted. The following actions will be activated in EVO:

- **EVO™ in Charging Mode:** Charging will stop but AC input power will continue to be passed through (*Internally, the EVO™ will be in Charging Mode, but the charging current will be reduced to 0A*). During this condition, the "Charging Mode Screens" will display message "Charger Off by BMS" as follows:
 - EVO-1212F / EVO-1212F-HW / EVO-1224F / EVO-1224F-HW: Fig 3.7(a), Section 3.6.8.1
 - (i) EVO-2212 / EVO-3012 / EVO-2224 / EVO-4024 and (ii) EVO-2212E / EVO-3012E / EVO-2224E / EVO-4024E: Fig 3.7(b), Section 3.6.8.2
 - EVO-4248SP: Fig 3.7(c), Section 3.6.8.3
- **EVO™ in Inverting Mode:** Inverting will stop (*Internally, the EVO™ will enter Standby Mode*). During this condition, the "Inverting Mode Screens" will display message "Inv stop by BMS" as follows:
 - EVO-1212F / EVO-1212F-HW / EVO-1224F / EVO-1224F-HW: Fig 3.8(a), Section 3.6.9.1
 - (i) EVO-2212 / EVO-3012 / EVO-2224 / EVO-4024 and (ii) EVO-2212E / EVO-3012E / EVO-2224E / EVO-4024E: Fig 3.8(b), Section 3.6.9.2
 - EVO-4248SP: Fig 3.8(c), Section 3.6.9

NOTE: Parameter "CHARGING PROFILE" will be required to be programmed to select the desired charging profile for the Lithium Ion Battery from the following options:

- 1=3 Stage Type 1
- 2=3 Stage Type 2
- 3=2 Stage Type 1
- 4=2 Stage Type 2
- 5=2 Stage Type 3

(For details, please refer to parameter "CHARGING PROFILE" explained under Section 4.4.2.21)

SECTION 4 | Parameter Setup

4.4.2.22.3 Programming Steps for Parameter "BATTERY TYPE"

Any Operating Mode Screen from Fig 3.1 to 3.8

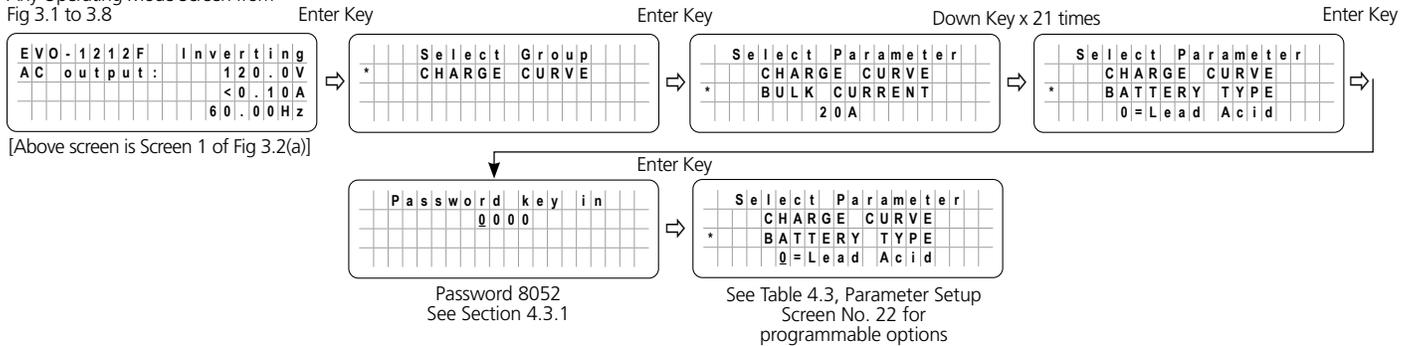

4.4.2.23 SAFE CHARGING (Table 4.1, Parameter Setup Screen No. 23)

4.4.2.23.1 General Information

Programming parameter "SAFE CHARGING" is a Timer (0 to 300 min; Default: 0 min) that may be used for the following operational conditions / requirements:

- The unit is programmed to operate in Normal (Off-line) Mode (Parameter MODE set to "0= Normal" – See Section 4.4.2.13) i.e. AC input power is the primary source of AC power and EVO's Inverter Section is the backup source.
- The AC load(s) that are fed with backup power from EVO™ have very high inrush current.
- When AC input power is restored during "Battery low voltage!" fault condition (Section 7, Srl. 1 of Table 7.1), EVO™ will exit fault condition and change to "Charging Mode" (say, "Condition 1"). The AC input power may fail again within a short period of time and EVO™ will immediately revert back to "Inverting Mode" (say, "Condition 2"). During "Condition 1", the battery voltage may not have risen appreciably higher than the "BATT LOW VOLTAGE" threshold (Section 4.4.2.9). Hence, during "Condition 2", there would be **MORE** likelihood that high inrush current from the AC load(s) would drag the battery voltage down to (i) 9V or lower for EVO-1212F/ 1212F-HW/ 2212/ 2212E/ 3012/ 3012E or, (ii) 18V or lower for EVO-1224F/ 1224F-HW/ 2224/ 2224E/ 4024/ 4024E or, (iii) 36V or lower for EVO-4248SP. This may trigger "Battery ultra low volt!" fault condition (Section 7, Srl. 2 of Table 7.1). It is, therefore, desirable that when AC input power is restored during "Battery low voltage!" fault condition (Condition 1) and fails again (Condition 2), the AC load(s) should NOT be transferred to the Inverter Section (under Condition 2) till the AC input power had been restored (under Condition 1) for a minimum safe charging time period set through Timer "SAFE CHARGING" (Section 4.4.2.23).

4.4.2.23.2 Initial Settings:

- As an example, assume that the timer associated with parameter "SAFE CHARGING" (Section 4.4.2.23) is set to > the Default setting of 0 min, say "t" min
- Parameter "LV CUT OFF TIME" (Section 4.4.2.11.2) is set to 0 sec to ensure that the unit does not shut down completely if AC input is not restored before expiry of time set through programming parameter "LV CUT OFF TIME" (Section 4.4.2.11)

SECTION 4 | Parameter Setup

4.4.2.23.3 Operating Sequence

- 1) AC input power is available – EVO™ operates in “Charging Mode”
- 2) AC input power fails: EVO™ transfers from “Charging Mode” to “Inverting Mode”
- 3) The battery continues to get discharged. When battery voltage (i) drops to value equal to / lower than the “BATT LOW VOLTAGE” threshold ([Section 4.4.2.9](#)) for period equal to LV DETECT TIME ([Section 4.4.2.10](#)) or (ii) momentarily drops for 1 ms to (i) 9V or below for EVO-1212F/1212F-HW/2212/2212E/3012/3012E or, (ii) 18V or below for EVO-1224F/1224F-HW/2224/2224E/4024/4024E or, (iii) 36V for EVO-4248SP, EVO’s Inverter Section is shut down and displays “Battery low voltage! fault / “Battery ultra low voltage!” fault conditions respectively ([See Srls. 1 and 2 of Table 7.1, Section 7](#)).
 - As parameter “LV CUT OFF TIME” ([Section 4.4.2.11.2](#)) has been set at 0 sec, the EVO™ does not shut down completely but continues to remain in “Battery low voltage!” / “Battery ultra low voltage!” fault condition
- 4) AC input power is restored and is within the programmed limits of frequency and voltage
- 5) EVO™ exits “Battery low voltage!” / “Battery ultra low voltage!” and starts operating in “Charging Mode” (say, “Operating Condition 1”)
 - As soon as “Charging Mode” is activated, the Timer associated with parameter “SAFE CHARGING” ([Section 4.4.2.23](#)) starts countdown:
 - o The “SAFE CHARGING” Timer will countdown to “0” min if AC input remains on for more than the programmed value of “t” min
 - o The “SAFE CHARGING” Timer will NOT countdown to “0” min if AC input remains on for period less than the programmed value “t” min
- 6) AC input fails again. The EVO™ will now operate as follows based on the condition of the “SAFE CHARGING” Timer that recorded the time AC input was available ([“Operating Condition 1” mentioned at Srl. 5 above](#)):
 - [“SAFE CHARGING” Timer value has counted down to 0 min](#): EVO™ will operate in “Inverting Mode”. As the batteries were re-charged for sizable time period > the programmed time “t” of the “SAFE CHARGING” timer, the battery would have charged appreciably higher than the “BATT LOW VOLTAGE” threshold ([Section 4.4.2.9](#)). Hence, there is **LESS** likelihood that high inrush current from the AC loads would drag the battery voltage down to (i) 9V or lower for EVO-1212F/1212F-HW/2212/2212E/3012/3012E or, (ii) 18V or lower for EVO-1224F/1224F-HW/2224/2224E/4024/4024E or, (iii) 36V for EVO-4248SP to trigger “Battery ultra low volt!” fault condition ([See Section 7, Srl. 2 of Table 7.1](#))
 - [“SAFE CHARGING” Timer value has NOT counted down to 0 min](#): EVO™ will **NOT** go to Inverting Mode but to “STANDBY” Mode ([See Screen No. 1 of STANDBY MODE screens in \(i\) Fig 3.1\(a\) for EVO-1212F/1212F-HW/1224F/1224F-HW or, \(ii\) Flg 3.1\(b\) for EVO-2212/2212E/3012/3012E/2224/2224E/4024/4024E or, \(iii\) Fig 3.1\(c\) for EVO-4248SP](#)). As the batteries were re-charged for a short time period < the programmed time “t” of the “SAFE CHARGING” timer ([“Operating Condition 1” mentioned at Srl. 5 above](#)), the battery would NOT have charged appreciably higher than the “BATT LOW VOLTAGE” threshold ([Section 4.4.2.9](#)). Hence, there would be **MORE** likelihood that high inrush current from the AC loads would drag the battery voltage down to (i) 9V or lower for EVO-1212F/1212F-HW/2212/2212E/3012/3012E or, (ii) 18V or lower for EVO-1224F/1224F-HW/2224/2224E/4024/4024E or, (iii) 36V for EVO-4248SP to trigger “Battery ultra low volt!” fault condition ([See Section 7, Srl. 2 of Table 7](#)) that would require manual reset.
 - If the battery is charged through external charging source ([e.g. solar charging through Charge Controller connected to the battery directly or, through terminals marked “EXT Charger” on the front panel of the unit](#)) to voltage threshold set by parameter “RESET VOLTAGE” ([Section 4.4.2.7](#)), the EVO™ will change to “INVERTING MODE”

SECTION 4 | Parameter Setup

4.5 GROUP 2 PARAMETER SET UP: INPUT SETTING

4.5.1 Programming Ranges & Default Values of Programming Parameters under Parameter Group 2 – INPUT SETTING

Table 4.6 gives details of programming ranges & default values of parameters under Parameter Group No.2 - "INPUT SETTING". Refer to Fig 4.3 under Section 4.1.3.2 for Menu Map for navigating through various parameters under this Group No.2.

Parameter Setup Screen Nos. for: EVO-1212F, 1212F-HW, 1224F, 1224F-HW, 4248SP (Column 1)	Parameter Setup Screen Nos. for: EVO-2212/ 2212E, 3012/ 3012E, 2224/ 2224E, 4024/ 4024E (Column 2)	Parameter (Column 3)	Setting range											
			EVO-1212F /1212F-HW (Column 4)	EVO-2212 (Column 5)	EVO-3012 (Column 6)	EVO-1224F /1224F-HW (Column 7)	EVO-2224 (Column 8)	EVO-4024 (Column 9)	EVO-4248SP (Column 10)	EVO-2212E (Column 11)	EVO-3012E (Column 12)	EVO-2224E (Column 13)	EVO-4024E (Column 14)	
1	1	DEFAULT FREQ	See NOTE 1 0=60Hz; (Default: 60Hz)	0=60Hz; 1=50Hz (Default: 0=60Hz)		See NOTE 1 0=60Hz; (Default: 0=60Hz)	0=60Hz; 1=50Hz (Default: 0=60Hz)			0=50Hz; 1=60Hz (Default: 0=50Hz)				
2	2	GRID MAX CURRENT	5 – 20A (Default: 20A)	5 – 40A (Default: 30A)	5 – 70A (Default: 30A)	5 – 20A (Default: 20A)	5 – 40A (Default: 30A)	5 – 70A (Default: 30A)	5 – 30A (Default: 30A)	5 – 20A (Default: 16A)	5 – 25A (Default: 16A)	5 – 20A (Default: 16A)	5 – 35A (Default: 16A)	
- (See NOTE 2)	3	GEN MAX CURRENT		5 – 40A (Default: 30A)	5 – 70A (Default: 30A)		5 – 40A (Default: 30A)	5 – 70A (Default: 30A)		5 – 20A (Default: 16A)	5 – 25A (Default: 16A)	5 – 20A (Default: 16A)	5 – 35A (Default: 16A)	
3	4	HIGH CUT OFF	50 – 70Hz (Default: 65Hz)							50 – 70Hz (Default: 55Hz)				
4	5	HIGH RESET	50 – 70Hz (Default: 64Hz)							50 – 70Hz (Default: 54Hz)				
5	6	LOW CUT OFF	40 – 60Hz (Default: 55Hz)							40 – 60Hz (Default: 45Hz)				
6	7	LOW RESET	40 – 60Hz (56Hz)							40 – 60Hz (Default: 46Hz)				
7	- (See NOTE 3)	SYNCHRONIZATION	0=Fine (Default) 1=Coarse			0=Fine (Default) 1=Coarse			0=Fine (Default) 1=Coarse					
- (See NOTE 4)	8	SYNC GRID		0=Fine (Default) 1=Coarse			0=Fine (Default) 1=Coarse					0=Fine (Default) 1=Coarse		
- (See NOTE 4)	9	SYNC GEN		1=Coarse (Default) 0=Fine			1=Coarse (Default) 0=Fine					1=Coarse (Default) 0=Fine		
8	10	INPUT OC PROTECT	0=INV mode (Default) 1=Shutdown											
9	11	INPUT RECOVERY	0=Buffered (Default) 1=Direct											

SECTION 4 | Parameter Setup

If the net AC input current is 1A more than the value of parameter GRID MAX CURRENT for 1 sec, the AC side charging current is clawed back to ensure that GRID MAX CURRENT value is not exceeded. If the value of pass through load current increases to a value of 1A more than the programmed value of GRID MAX CURRENT for 5 sec, input over current protection will be activated based on option to either transfer to Inverting Mode or to shut down the EVO™ (Refer to details of these 2 options under parameter **INPUT OC PROTECT** at Section 4.5.2.11):

4.5.2.2.1 Programming Steps for Parameter "GRID MAX CURRENT"

Any Operating Mode Screen from Fig 3.1 to 3.8

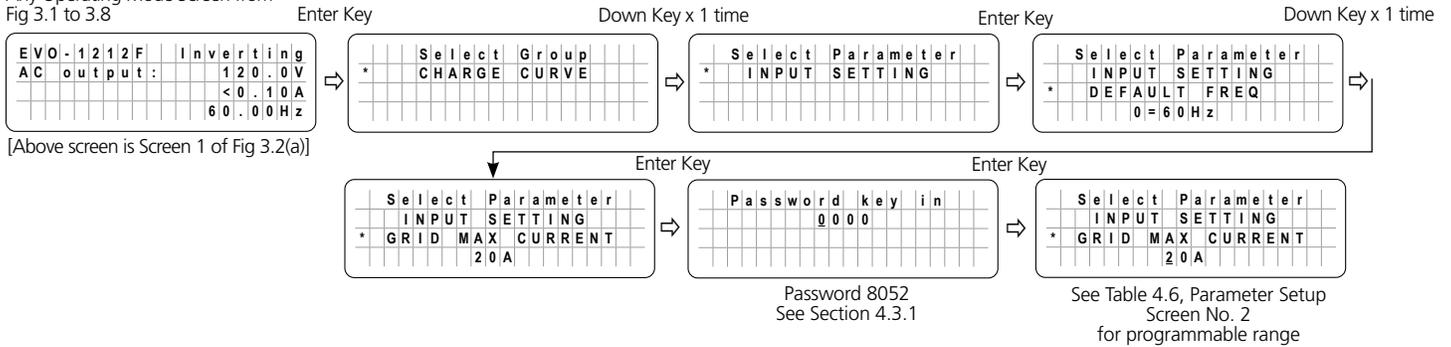

4.5.2.3 GEN MAX CURRENT (Table 4.6, Parameter Setup Screen No.3 for EVO-2212/EVO-3012/EVO-2224/EVO-4024)

NOTE: This parameter is available **ONLY** for EVO-2212/2212E/EVO-3012/3012E/EVO-2224/2224E/EVO-4024/4024E. This parameter setting is **NOT** available for EVO-1212F / EVO-1212F-HW / EVO-1224F / EVO-1224F-HW / EVO-4248SP.

In Charging Mode, the net AC input current from the AC input terminals marked "GEN" is the sum of the AC side charging current and the pass through load current. Based on the rated capacity of the AC source connected to AC Input Terminals marked "GEN", the net AC input current will be required to be limited to prevent overloading of the AC input source.

EVO™ Series has a very powerful battery charger that will require a proportionate higher AC input current from the AC input source. The AC source connected to AC input terminals marked "GEN" will also be required to provide current to the AC loads. The desired maximum value of input current from the AC input source connected to AC input terminals marked "GEN" can be programmed (Default is 30A for EVO-2212/3012/2224/4024 and 16A for EVO-2212E/3012E/2224E/4024E). The EVO™ will automatically reduce charging current to support the AC loads on priority and use whatever is extra for charging. This will prevent overloading of the AC input source. If the net AC input current is 1A more than the value of parameter "GEN MAX CURRENT" for 1 sec, the AC side charging current is clawed back to ensure that "GEN MAX CURRENT" value is not exceeded. If the value of pass through load current increases to a value of 1A more than the programmed value of "GEN MAX CURRENT" for 5 sec, input over current protection will be activated based on option to either transfer to Inverting Mode or to shut down the EVO™ (Refer to details of these 2 options under parameter **INPUT OC PROTECT** at Section 4.5.2.11):

SECTION 4 | Parameter Setup

4.5.2.5.1 Programming Steps for Parameter "HIGH RESET"

Any Operating Mode Screen from Fig 3.1 to 3.8

EVO-1212F	Inverting
AC output:	120.0V
	< 0.10A
	60.00Hz

[Above screen is Screen 1 of Fig 3.2(a)]

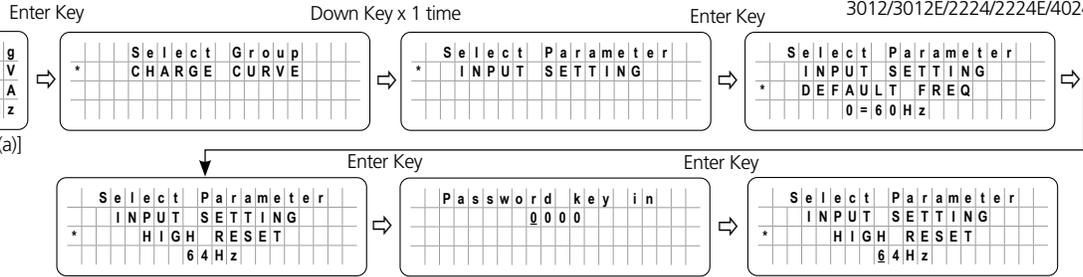

Password 8052
See Section 4.3.1

For programmable range, see Table 4.6:
(i) Parameter Setup Screen No. 4 (Column 1) for EVO-1212F/1212F-HW/1224F-E/1224F-HW/4248SP
(ii) Parameter Setup Screen No. 5 (Column 2) for EVO-2212/2212E/3012/3012E/2224/2224E/4024/4024E

4.5.2.6 LOW CUT OFF *(Table 4.6: (i) Parameter Setup Screen No.5 (Column 1) for EVO-1212F / EVO-1212F-HW / EVO-1224F / EVO-1224F-HW / EVO-4248SP
(ii) Parameter Setup Screen No.6 (Column 2) for EVO-2212/ 2212E / 3012 / 3012E / 2224 / 2224E / 4024 / 4024E)*

If the AC input frequency is below "LOW CUT OFF" value when in "Charging Mode", the EVO™ Inverter/Charger will transfer to Inverting Mode.

4.5.2.6.1 Programming Steps for Parameter "LOW CUT OFF"

Any Operating Mode Screen from Fig 3.1 to 3.8

EVO-1212F	Inverting
AC output:	120.0V
	< 0.10A
	60.00Hz

[Above screen is Screen 1 of Fig 3.2(a)]

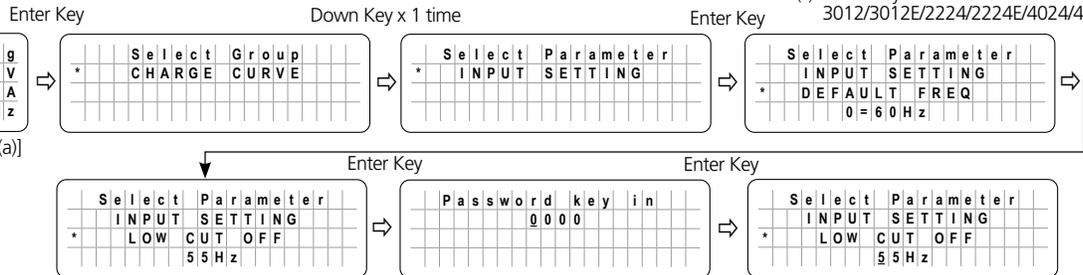

Password 8052
See Section 4.3.1

For programmable range, see Table 4.6:
(i) Parameter Setup Screen No. 5 (Column 1) for EVO-1212F/1212F-HW/1224F-E/1224F-HW/4248SP
(ii) Parameter Setup Screen No. 6 (Column 2) for EVO-2212/2212E/3012/3012E/2224/2224E/4024/4024E

4.5.2.7 LOW RESET *(Table 4.6: (i) Parameter Setup Screen No.6 (Column 1) for EVO-1212F / EVO-1212F-HW / EVO-1224F / EVO-1224F-HW / EVO-4248SP
(ii) Parameter Setup Screen No.7 (Column 2) for EVO-2212/ 2212E / 3012 / 3012E / 2224 / 2224E / 4024 / 4024E)*

This is the reset frequency at which the unit will revert to "Charging Mode" after it has switched over to "Inverting Mode" due to input frequency falling below "LOW CUT OFF".

SECTION 4 | Parameter Setup

4.5.2.7.1 Programming Steps for Parameter "LOW RESET"

Any Operating Mode Screen from Fig 3.1 to 3.8

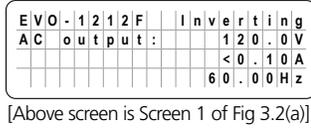

Enter Key

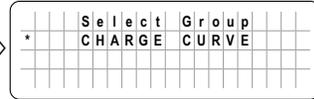

Down Key x 1 time

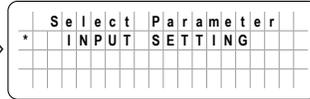

Enter Key

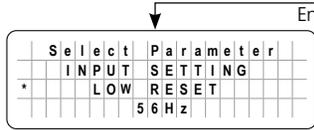
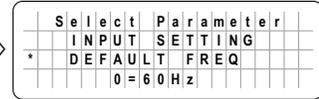

Enter Key

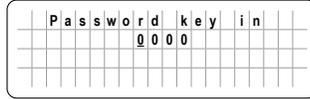

Password 8052
See Section 4.3.1

Enter Key

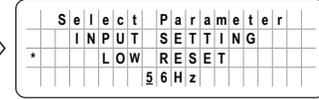

For programmable range, see Table 4.6:
(i) Parameter Setup Screen No. 6 (Column 1) for EVO-1212F/1212F-HW/1224F/E/1224F-HW/4248SP
(ii) Parameter Setup Screen No. 7 (Column 2) for EVO-2212/2212E/3012/3012E/2224/2224E/4024/4024E

4.5.2.8 SYNCHRONIZATION (Table 4.6, Parameter Screen No. 7 under Column 1 for EVO-1212F/1212F-HW/1224F/122F-HW)

NOTE: Parameter "SYNCHRONIZATION" is **NOT** available for EVO-2212 / 3012 / 2224 / 4024 and EVO-2212E / 3012E / 2224E / 4024E

In EVO-1212F/1212F-HW/1224F/1224F-HW/4248SP the frequency and phase of the Inverter Section are always kept synchronized with the AC input source. This facilitates faster and safer transfer of power between the Inverter Section and the AC input source. *For supplementary details on synchronized transfer of AC power, please refer to Sections 4.4.2.1.1 to 4.4.2.1.4 of the Owner's Manuals for (i) EVO-1212F/1212F-HW/1224F/1224F-HW and, (ii) EVO-4248SP.*

In EVO-1212F/1212F-HW/1224F/1224F-HW/4248SP, parameter "SYNCHRONIZATION" is used to program the desired sensitivity of frequency and phase synchronization of the Inverter Section with the AC input source.

2 programming options are available for parameter "SYNCHRONIZATION" for EVO-1212F/1212F-HW/1224F/1224F-HW/4248SP. These options are: (i) Option "0= Fine" – see Section 4.5.2.8(a) below and (ii) Option "1= Coarse" – see Section 4.5.2.8(b) below.

When EVO™ is operating in Inverting Mode (there is no AC input), its output frequency will be equal to the frequency that has been selected by the programming parameter "DEFAULT FREQ" (TABLE 4.6 and Section 4.5.2.1). When AC input is made available, it is first monitored for 2 sec. If it is within the programmed values of (i) frequency limits (TABLE 4.6), (ii) low voltage limits (TABLE 4.7) and (iii) high voltage limits (TABLE 4.8), synchronization process is initiated to synchronize the frequency and phase of the Inverter Section with the incoming AC input voltage. Details are given below:

a) Parameter "SYNCHRONIZATION" set at Option "0= Fine"

This is the "Default Setting" for EVO-1212F/1212F-HW/1224F/1224F-HW/4248SP. Synchronization control logic used in this option is more suitable for AC input source that has very stable frequency like the Grid or Inverter Generator. Under this option, the frequency and phase of the Inverter Section are synchronized with the AC input source as follows:

- i. First, the frequency of the Inverter Section is tracked in steps of 0.1Hz per cycle and made equal to the frequency of the AC input source.
- ii. Then, the phase of the Inverter voltage relative to the AC input voltage is tracked by 1° per cycle. When the phase of the Inverter voltage is within ± 3.5° of the input voltage waveform, the Transfer Relay is activated to transfer the AC load from the AC input source to the Inverter Section at zero crossing of the voltage waveform.

SECTION 4 | Parameter Setup

b) Parameter "SYNCHRONIZATION" set at Option 1= Coarse

This setting is selected for EVO-1212F/1212F-HW/1224F/1224F-HW/4248SP if the AC input source is a Generator. As compared to very stable frequency of Grid / Inverter Generator, the frequency of a Generator may vary considerably depending upon the performance of its Speed Governor that compensates for the drop in RPM / frequency when electrical load is switched on / increased or, rise in RPM / frequency when electrical load is decreased /switched off. Hence, if synchronization sensitivity is set at "0= Fine" as in Section 4.5.2.8 (a) above, it may take very long for the Inverter Section to synchronize with the Generator or, may not synchronize at all. Under this option, the frequency and phase of the Inverter Section are synchronized with the Generator *differently* as follows:

- First, the frequency of the Inverter Section is *NOT tracked at 0.1Hz per cycle as in Option "0= Fine" [See Section 4.5.2.8(a) above]* but is made equal to the Generator frequency at zero crossing of the Inverter voltage.
- Then, the phase of the Inverter voltage relative to the phase of the Generator voltage is tracked by 1° per cycle. When the phase of the Inverter Section is within $\pm 10.5^\circ$ of the Generator input voltage waveform, the Transfer Relay is activated to transfer the AC load from the Generator to the Inverter Section at zero crossing of the voltage waveform.

4.5.2.8.1 Programming Steps for Parameter "SYNCHRONIZATION"

(Only for EVO-1212F/1212F-HW/1224F/1224F-HW/4248SP)

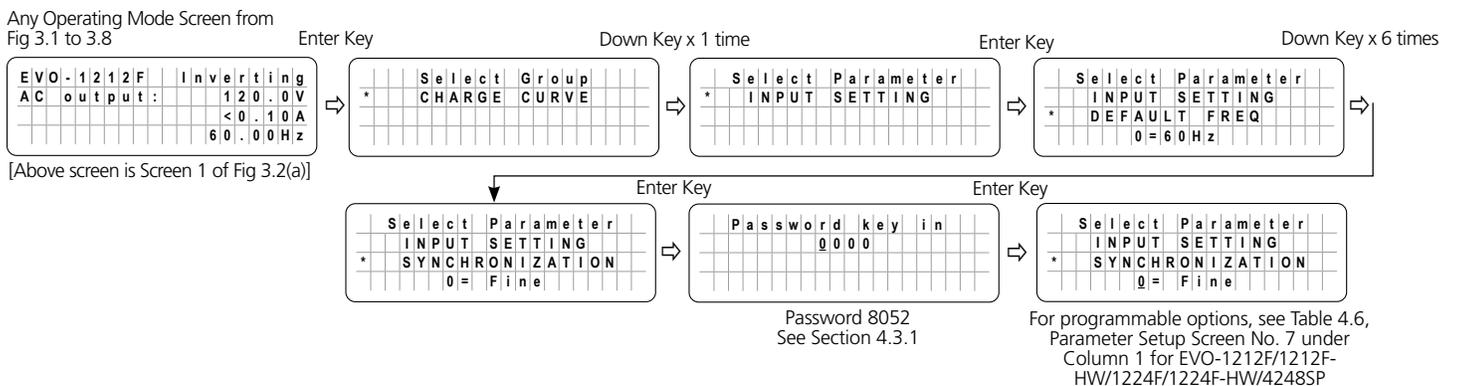

4.5.2.9 SYNC GRID *(Table 4.6, Parameter Setup Screen No. 8 under Column 2 for EVO-2212/ 2212E / 3012 / 3012E / 2224 / 2224E / 4024 / 4024E)*

NOTE: *Parameter "SYNC GRID" is NOT available for EVO-1212F/1212F-HW/1224F/1224F-HW/4248SP.*

In EVO-2212/ 2212E / 3012 / 3012E / 2224 / 2224E / 4024 / 4024E, the frequency and phase of the Inverter Section are always kept synchronized with the AC input source connected to terminals marked "GRID" (4,5,6 in Fig 2.3 in Owner's Manuals for (i) EVO-2212/3012/2224/4024 and (ii) EVO-2212E/3012E/2224E/4024E). This facilitates faster and safer transfer of power between the Inverter Section and the AC input source.

NOTE: *For supplementary details on synchronized transfer of AC power, please refer to Section 4.5.4 to 4.5.7 of Owner's Manuals for (i) EVO-2212/3012/2224/4024 and (ii) EVO-2212E/3012E/2224E/4024E*

SECTION 4 | Parameter Setup

Parameter "SYNC GRID" is used to program the desired sensitivity of frequency and phase synchronization of the Inverter Section with the AC input voltage fed at the AC Input Terminals marked "GRID" (4,5,6 in Fig 2.3 in Owner's Manuals for (i) EVO-2212/3012/2224/4024 and (ii) EVO-2212E/3012E/2224E/4024E).

2 programming options are available for this parameter: (i) Option "0= Fine" (Default option) – see Section 4.5.2.9(a) below and (ii) Option "1= Coarse" – see Section 4.5.2.9(b) below.

When EVO-2212/ 2212E / 3012 / 3012E / 2224 / 2224E / 4024 / 4024E is operating in Inverting Mode (there is no AC input), its output frequency will be equal to the frequency that has been selected by the programming parameter "DEFAULT FREQ" (TABLE 4.6 and Section 4.5.2.1). When AC input is made available at AC Input Terminals marked "GRID" (4,5,6 in Fig 2.3 in Owner's Manuals for (i) EVO-2212/3012/2224/4024 and (ii) EVO-2212E/3012E/2224E/4024E), it is first monitored for 2 sec. If it is within the programmed values of (i) frequency limits (TABLE 4.6), (ii) low voltage limits (TABLE 4.7) and (iii) high voltage limits (TABLE 4.8), synchronization process is initiated to synchronize the frequency and phase of the Inverter Section with the incoming AC input voltage. Details are given below:

a) Parameter "SYNC GRID" set at Option "0= Fine" (Default)

This is the "Default Setting". This setting is applicable when Grid / Inverter Generator is connected to AC Input Terminals marked "GRID" (4,5,6 in Fig 2.3 in Owner's Manuals for (i) EVO-2212/3012/2224/4024 and (ii) EVO-2212E/3012E/2224E/4024E). Synchronization control logic used in this option is suitable for more stable frequency output of Grid / Inverter Generator. Under this option, the frequency and phase of the Inverter Section are synchronized with the Grid as follows:

- i. First, the frequency of the Inverter Section is tracked in steps of 0.1Hz per cycle and made equal to the frequency of the Grid / Inverter Generator input.
- ii. Then, the phase of the Inverter voltage relative to the Grid voltage is tracked by 1° per cycle. When the phase of the Inverter voltage is within $\pm 3.5^\circ$ of the input voltage waveform, the Transfer Relay is activated to transfer the AC load from the Grid / Inverter Generator to the Inverter Section at zero crossing of the voltage waveform.

Parameter SYNC GRID set at Option 1= Coarse

This setting is selected if a Generator is connected to AC Input Terminals marked "GRID" (4,5,6 in Fig 2.3 in Owner's Manuals for (i) EVO-2212/3012/2224/4024 and (ii) EVO-2212E/3012E/2224E/4024E). As compared to very stable frequency of Grid / Inverter Generator, the frequency of a Generator may vary considerably depending upon the performance of its Speed Governor that compensates for the drop in RPM / frequency when electrical load is switched on / increased or, rise in RPM / frequency when electrical load is decreased /switched off. Hence, if synchronization sensitivity set is at "0= Fine" as in Section 4.5.2.9 (a) above, it may take very long for the Inverter Section to synchronize with the Generator or, may not synchronize at all. Under this option, the frequency and phase of the Inverter Section are synchronized with the Generator differently as follows:

- i. First, the frequency of the Inverter Section is NOT tracked at 0.1Hz per cycle as in Option "0= Fine" [See Section 4.5.2.9(a) above] but is made equal to the Generator frequency at zero crossing of the Inverter voltage.
- ii. Then, the phase of the Inverter voltage relative to the phase of the Generator / Inverter Generator voltage is tracked by 1° per cycle. When the phase of the Inverter Section is within $\pm 10.5^\circ$ of the Generator input voltage waveform, the Transfer Relay is activated to transfer the AC load from the Generator to the Inverter Section at zero crossing of the voltage waveform.

SECTION 4 | Parameter Setup

4.5.2.12 INPUT RECOVERY

(Table 4.6: (i) Parameter Screen No. 9 under Column 1 for EVO-1212F/1212F-HW/1224F/1224F-HW/4248SP
(ii) Parameter Setup Screen No. 11 under Column 2 for EVO-2212/2212E/3012/3012E/
2224/2224E/4024/4024E)

This parameter determines how EVO™ will recover when AC input is made available while in “Battery low voltage!” or “Battery ultra low voltage!” fault conditions (Srl. Nos. 1 and 2 respectively of TABLE 7.1). The following 2 options are available under this parameter:

- Option “0=Buffered” (This is the default option)
- Option “1=Direct”

When the EVO™ is in “Battery low voltage!” condition (Section 7, Srl 1 of TABLE 7) or in “Battery ultra low voltage!” condition (Section 7, Srl. 2 of TABLE 7.1) and if AC input is made available before expiry of time set by parameter “LV CUT OFF TIME” (Section 4.4.2.11), the “Battery low voltage!” / “Battery ultra low voltage!” fault conditions will be cleared and EVO™ Inverter/Charger will recover based on the following 2 options:

- Option 0=Buffered (Default):** Under this option, the unit will initially start in “Inverting Mode”, synchronize with the AC input and then transfer to “Charging Mode”. However, if a user programs the value of “BATTERY LOW VOLTAGE” very close to the “Battery ultra low voltage!” fault threshold of (i) 9V for 1 ms for EVO-1212F/1212F-HW/2212/3012 or, (ii) 18V for 1 ms for EVO-1224F/1224F-HW/2224/4024 or, (iii) 36V for 1ms for EVO-4248SP (Table 7.1), a larger load / larger starting surge on the inverter may drag the battery voltage to 9V / 18V / 36V or below for 1 ms and trigger “Battery ultra low voltage!” fault. Under this condition, the user may change to Option 1=Direct
- Option 1=Direct:** Under this option, the unit will directly start in “Charging Mode”

4.5.2.12.1 Programming Steps for Parameter “INPUT RECOVERY”

Any Operating Mode Screen from Fig 3.1 to 3.8

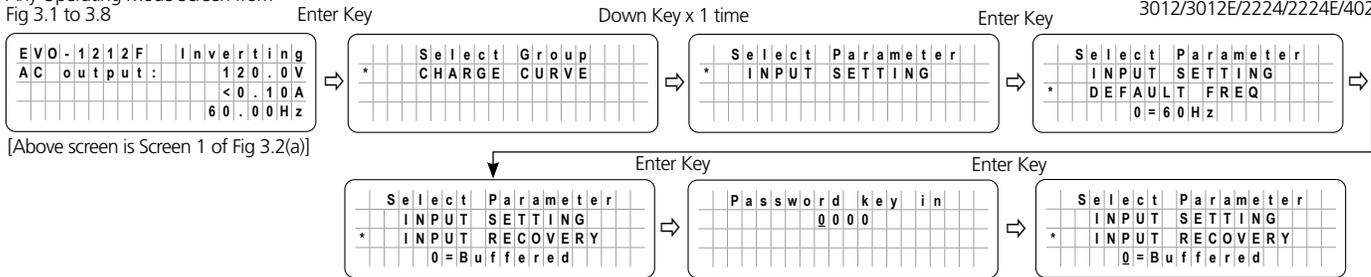

[Above screen is Screen 1 of Fig 3.2(a)]

(i) Down Key x 8 times for EVO-1212F/1212F-HW/1224F/1224F-HW/4248SP
(ii) Down Key x 10 times for EVO-2212/2212E/3012/3012E/2224/2224E/4024/4024

Password 8052
See Section 4.3.1

For programmable options, see Table 4.6:
(i) Parameter Setup Screen No. 9 under Column 1 for EVO-1212F/1212F-HW/1224F/1224F-HW/4248SP
(ii) Parameter Setup Screen No. 11 under Column 2 for EVO-2212/2212E/3012/3012E/2224/2224E/4024/4024E

4.6 GROUP 3 PARAMETER SET UP: INPUT LOW LIMIT

4.6.1 Programming Ranges and Default / Factory Preset Values of Parameters under Group 3 - INPUT LOW LIMIT

Table 4.7 gives details of programming ranges and default values of parameters under Group 3 - INPUT LOW LIMIT. Refer to Fig 4.3 under Section 4.1.3.2 for Menu Map for navigating through the various parameters under this Group 3.

SECTION 4 | Parameter Setup

Table 4.7 Group 3 Parameter Set Up: INPUT LOW LIMIT (Refer to Menu Map at Fig 4.3, Section 4.1.3.2)

Parameter Setup Screen No. (Column 1)	Parameter (Column 2)	Setting range		
		• EVO-1212F/1212F-HW/1224F /1224F-HW •EVO-2212 / 3012 / 2224 / 4024 (Column 3)	EVO-2212E / 3012E / 2224E / 4024E (Column 4)	EVO-4248SP (Column 5)
1	RESET VOLTAGE	60.0 - 120.0V (Default:105.0V)	140.0 - 200.0V (Default:190.0V)	60.0 - 200.0V (Default:195.0V)
2	CUT OFF VOLT 1	60.0 - 120.0V (Default: 100.0V)	140.0 - 200.0V (Default:180.0V)	60.0 - 200.0V (Default:185.0V)
3	DETECT TIME 1	0 - 2000 cycles (Default: 300 cycles)	0 - 2000 cycles (Default: 300 cycles)	0 - 2000 cycles (Default: 300 cycles)
4	CUT OFF VOLT 2	60.0 - 120.0V (Default: 95.0V)	140.0 - 200.0V (Default:170.0V)	60.0 - 200.0V (Default:175.0V)
5	DETECT TIME 2	0 - 2000 cycles (Default: 60 cycles)	0 - 2000 cycles (Default: 60 cycles)	0 - 2000 cycles (Default: 60 cycles)
6	CUT OFF VOLT 3	60.0 - 120.0V (Default: 90.0V)	140.0 - 200.0V (Default:160.0V)	60.0 - 200.0V (Default:165.0V)
7	DETECT TIME 3	0 - 2000 cycles (Default: 1 cycle)	0 - 2000 cycles (Default: 1 cycle)	0 - 2000 cycles (Default: 1 cycle)

4.6.2 Description of Parameters Under Group 3 – INPUT LOW LIMIT

4.6.2.1 RESET VOLTAGE (Table 4.7, Parameter Setup Screen No.1)

This is the reset voltage at which the unit will revert to "Charging Mode" after it has switched over to "Inverting Mode" due to input voltage falling to "CUT-OFF VOLT 1 / CUT-OFF VOLT 2 / CUT-OFF VOLT3".

4.6.2.1.1 Programming Steps for Parameter "RESET VOLTAGE"

Any Operating Mode Screen from Fig 3.1 to 3.8

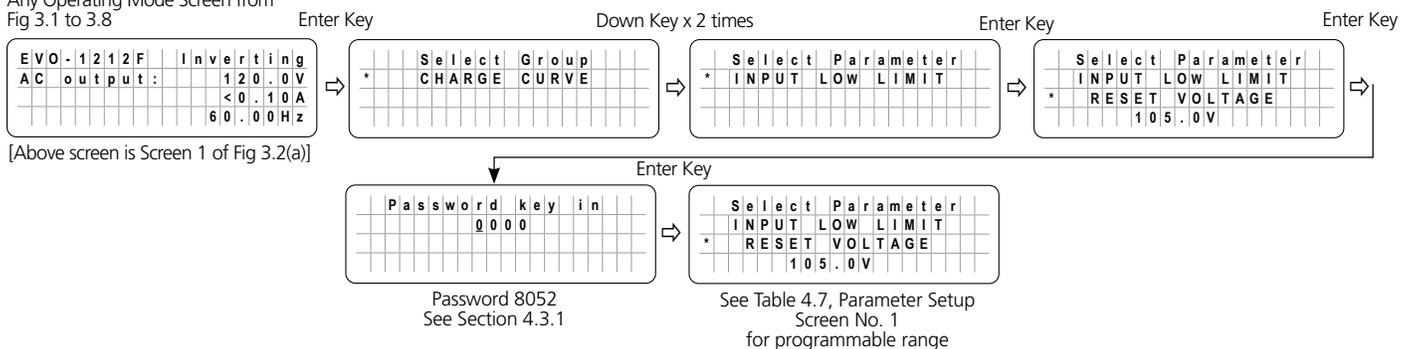

4.6.2.2 CUT OFF VOLT 1 (Table 4.7, Parameter Setup Screen No.2)

If during "Charging Mode", the AC input voltage falls below "CUT-OFF VOLT 1" for period > "DETECT TIME 1", the EVO™ Inverter/Charger will transfer to Inverting Mode from "Charging Mode".

SECTION 4 | Parameter Setup

4.6.2.2.1 Programming Steps for Parameter "CUT OFF VOLT 1"

Any Operating Mode Screen from Fig 3.1 to 3.8

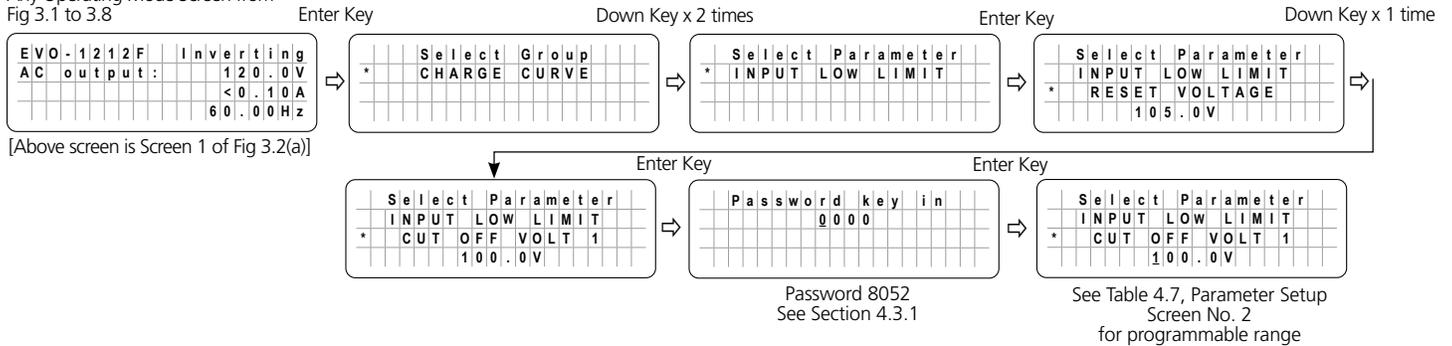

4.6.2.3 DETECT TIME 1 (Table 4.7, Parameter Setup Screen No.3)

This is the time limit in cycles up to which low AC input voltage "CUT-OFF VOLT 1" is allowed.

4.6.2.3.1 Programming Steps for Parameter "DETECT TIME 1"

Any Operating Mode Screen from Fig 3.1 to 3.8

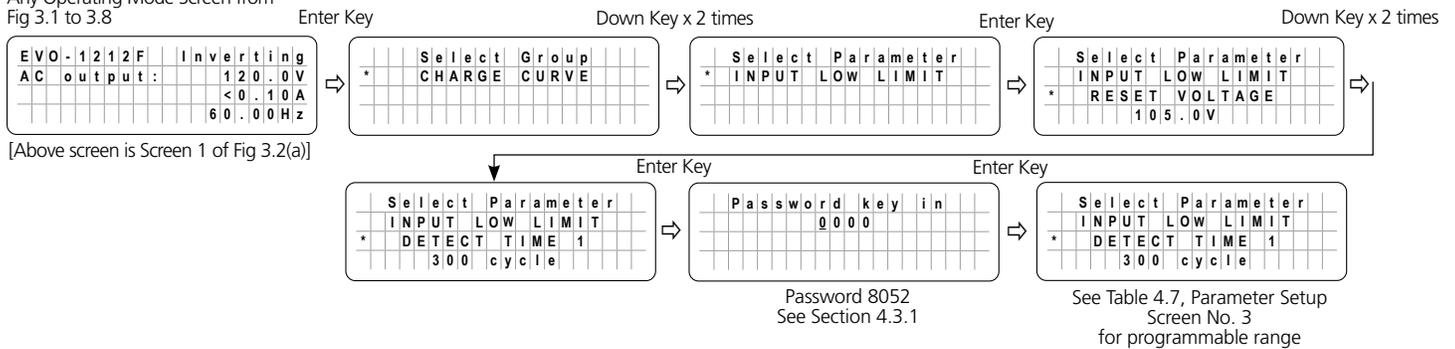

4.6.2.4 CUT OFF VOLT 2 (Table 4.7, Parameter Setup Screen No.4)

If during "Charging Mode", the AC input voltage falls below "CUT-OFF VOLT 2" for period > "DETECT TIME 2", the EVO™ Inverter/Charger will transfer to "Inverting Mode".

4.6.2.4.1 Programming Steps for Parameter "CUT OFF VOLT 2"

Any Operating Mode Screen from Fig 3.1 to 3.8

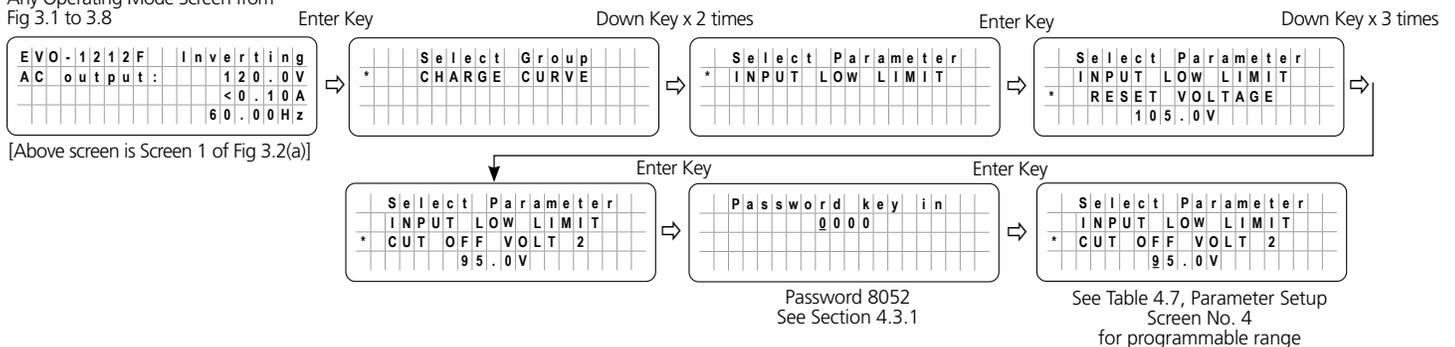

4.6.2.5 DETECT TIME 2 (Table 4.7, Parameter Setup Screen No.5)

This is the time limit in cycles up to which low AC input voltage "CUT-OFF VOLT 2" is allowed.

SECTION 4 | Parameter Setup

4.7.2.2 CUT OFF VOLT 1 (Table 4.8, Parameter Setup Screen No.2)

If during "Charging Mode", the AC input voltage rises above "CUT-OFF VOLT 1" for period > "DETECT TIME 1", the EVO™ Inverter/Charger will transfer to "Inverting Mode".

4.7.2.2.1 Programming Steps for Parameter "CUT OFF VOLT 1"

Any Operating Mode Screen from Fig 3.1 to 3.8

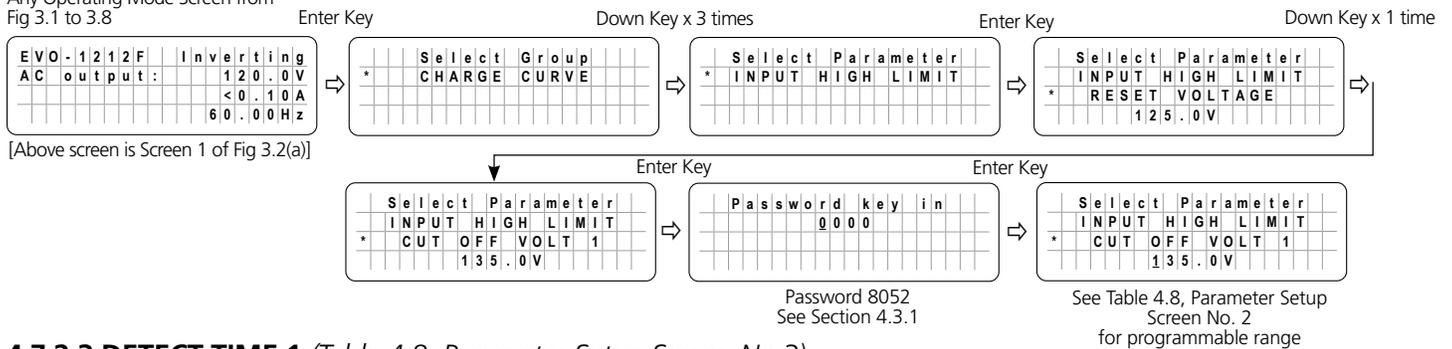

4.7.2.3 DETECT TIME 1 (Table 4.8, Parameter Setup Screen No.3)

This is the time limit in cycles up to which high AC input voltage "CUT-OFF VOLT 1" is allowed.

4.7.2.3.1 Programming Steps for Parameter "DETECT TIME 1"

Any Operating Mode Screen from Fig 3.1 to 3.8

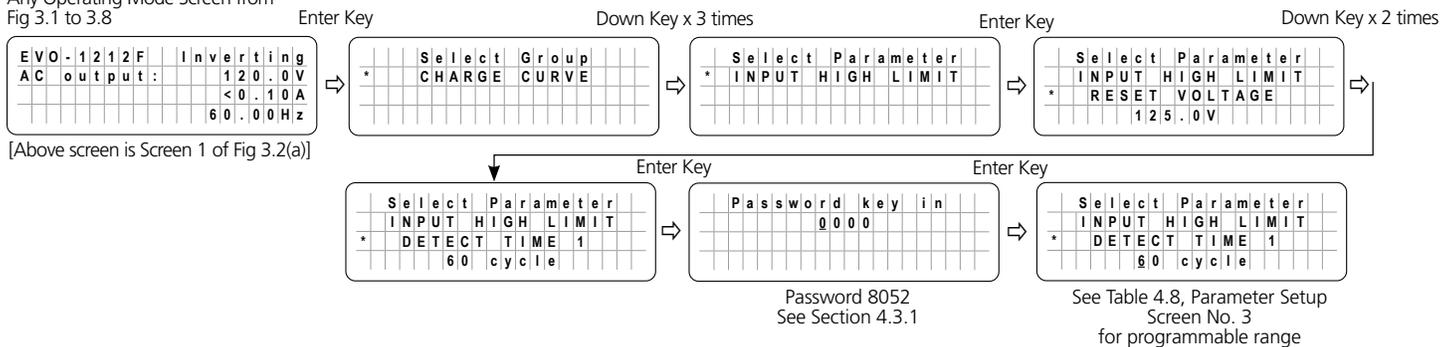

4.7.2.4 CUT OFF VOLT 2 (Table 4.8, Parameter Setup Screen No.4)

If during "Charging Mode", the AC input voltage rises above "CUT-OFF VOLT 2" for period > "DETECT TIME 2", the EVO™ Inverter/Charger will transfer to "Inverting Mode".

4.7.2.4.1 Programming Steps for Parameter "CUT OFF VOLT 2"

Any Operating Mode Screen from Fig 3.1 to 3.8

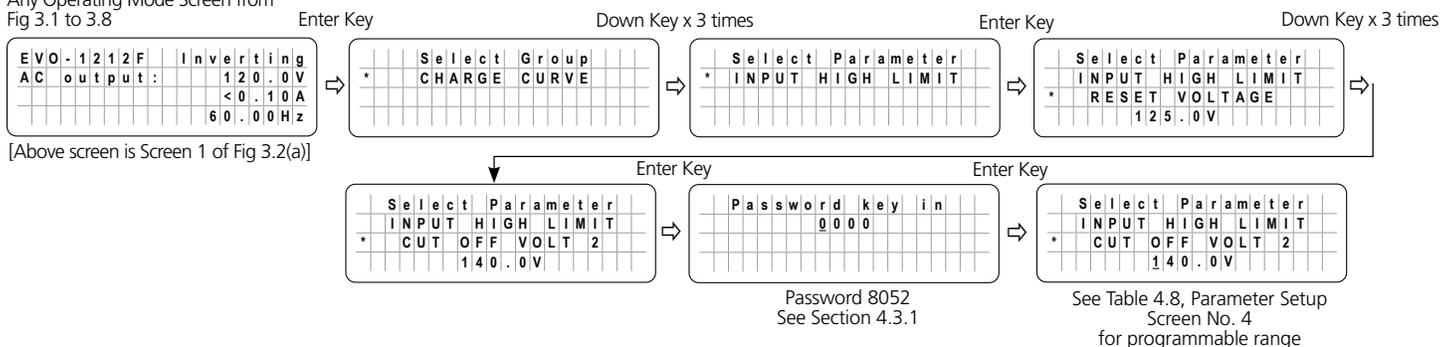

SECTION 4 | Parameter Setup

4.7.2.5 DETECT TIME 2 (Table 4.8, Parameter Setup Screen No.5)

This is the time limit in cycles up to which high AC input voltage "CUT-OFF VOLT 2" is allowed.

4.7.2.5.1 Programming Steps for Parameter "DETECT TIME 2"

Any Operating Mode Screen from Fig 3.1 to 3.8

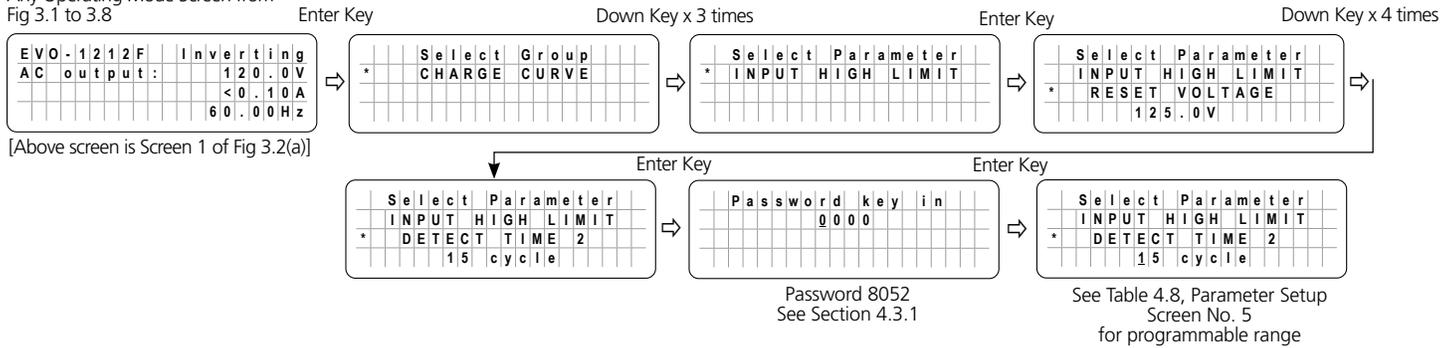

4.7.2.6 CUT OFF VOLT 3 (Table 4.8, Parameter Setup Screen No.6)

If during "Charging Mode", the AC input voltage rises above "CUT-OFF VOLT 3" for period > "DETECT TIME 3", the EVO™ Inverter/Charger will transfer to "Inverting Mode".

4.7.2.6.1 Programming Steps for Parameter "CUT OFF VOLT 3"

Any Operating Mode Screen from Fig 3.1 to 3.8

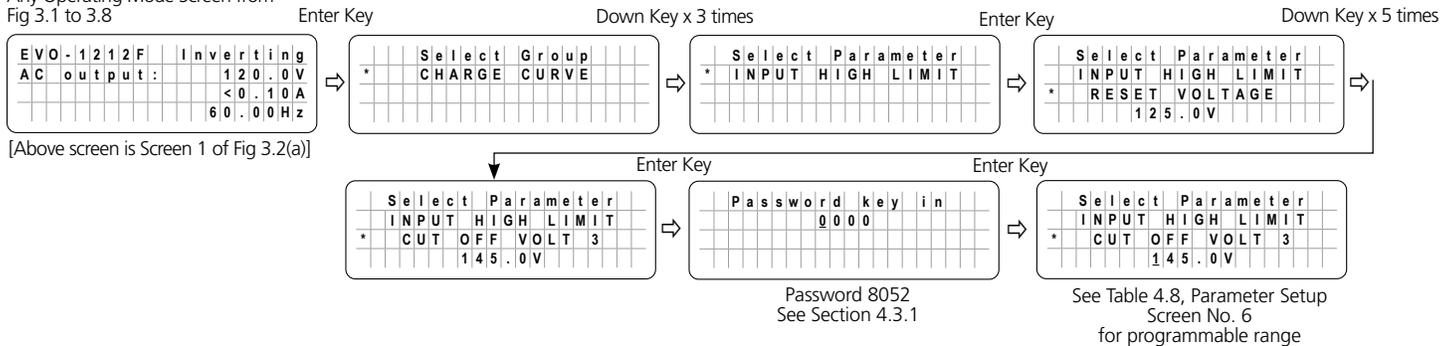

4.7.2.7 DETECT TIME 3 (Table 4.8, Parameter Setup Screen No.7)

This is the time limit in cycles up to which high AC input voltage "CUT-OFF VOLT 3" is allowed.

4.7.2.7.1 Programming Steps for Parameter "DETECT TIME 2"

Any Operating Mode Screen from Fig 3.1 to 3.8

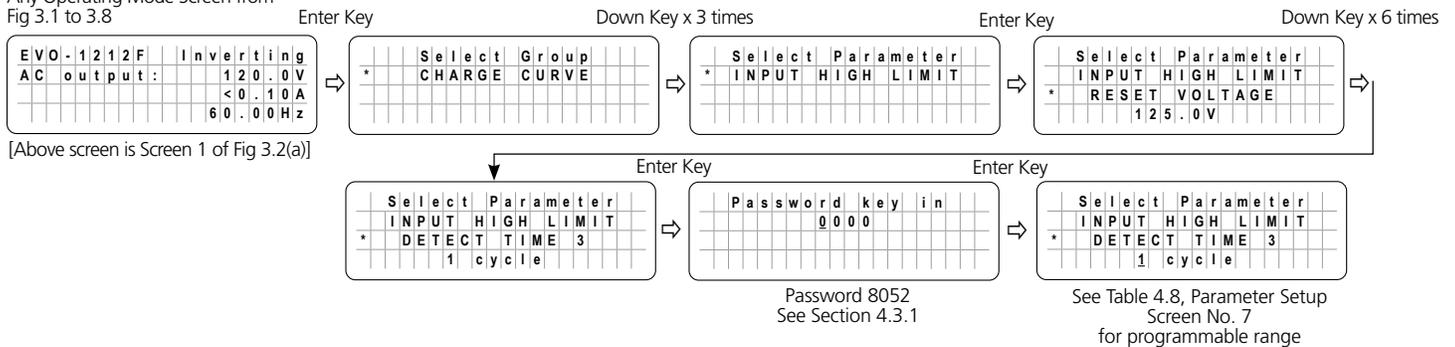

SECTION 4 | Parameter Setup

4.8 GROUP 5 PARAMETER SET UP: OTHER FUNCTIONS

4.8.1 Programming Ranges and Default / Factory Preset Values of Parameters under Group 5 - OTHER FUNCTION

Table 4.9 gives details of programming ranges and default values of parameters under Group 5 - OTHER FUNCTION. Refer to Fig 4.4 under Section 4.1.3.3 for Menu Map for navigating through the various parameters under this Group.

TABLE 4.9 Group 5 Parameter Set Up: OTHER FUNCTION (Refer to Menu Map at Fig 4.4, Section 4.1.3.3)

Parameter Setup Screen Nos. for EVO-1212F/ 1212F-HW/ 1224F/ 1224F-HW (Column 1)	Parameter Setup Screen Nos. for: • EVO-2212/ 3012/ 2224/ 4024 • EVO-2212E/ 3012E/ 2224E/ 4024E • EVO-4248SP (Column 2)	Parameter (Column 3)	Setting range						
			EVO-1212F EVO-1212F-HW (Column 4)	EVO-2212 EVO-2212E (Column 5)	EVO-3012 EVO-3012E (Column 6)	EVO-1224F EVO-1224F-HW (Column 7)	EVO-2224 EVO-2224E (Column 8)	EVO-4024 EVO-4024E (Column 9)	EVO-4248SP (Column 10)
1	1	POWER SAVING	0 = Disable ; 1 = Enable (Default: 0 = Disable)						
2	2	ENTER POINT	4 - 50W (Default: 6W)	4 - 50W (Default: 6W)	4 - 50W (Default: 8W)	4 - 50W (Default: 6W)	4 - 50W (Default: 6W)	4 - 50W (Default: 8W)	4 - 50W (Default: 8W)
3	3	WAKE UP POINT	5 - 50W (Default: 7W)	5 - 50W (Default: 7W)	5 - 50W (Default: 10W)	5 - 50W (Default: 7W)	5 - 50W (Default: 7W)	5 - 50W (Default: 10W)	5 - 50W (Default: 10W)
4	4	REMOTE SWITCH	0 = Button Type , 1 = Switch Type (Default: 0 = Button Type)						
- (See NOTE 1)	5	RELAY FUNCTION		0 = Charger / Other 1 = Normal / Fault 2 = Generator 0 3 = Generator 1 4 = Generator 2 (Default:2=Generator 0)				0 = Charger / Other 1 = Normal / Fault 2 = Generator 0 3 = Generator 1 4 = Generator 2 (Default:2=Generator 0)	
5	6	COMM ID	1 - 255 (Default: 1)						
6	7	BUZZER	0 = OFF ; 1 = ON (Default: 1 = ON)						
7	8	DISCHARGE BEEP	0 = OFF ; 1 = ON (Default: 0 = OFF)						
8	9	DEFAULT RESET	0 = No ; 1 = Yes (Default: 0 = No)						
9	10	DATALOG TIME	0 = Disable; 1 = 1 sec; 2 = 10 sec; 3 = 30 sec; 4 = 1 min; 5 = 5 min; 6 = 10 min (Default: 1 = 1 sec)						
10	11	PARAMETER SAVE	0 = No ; 1 = Yes (Default: 0 = No)						
11	12	TEMP UNIT	0 = °C ; 1 = °F (Default: 0 = °C)						
12	13	PASSWORD DISABLE	0 = No , 1 = Yes (Default: 0 = No)						

NOTES for Table 4.9:

- Parameter "RELAY FUNCTION" (Parameter Setup Screen No. 5 under Columns 2 & 3) is available only for EVO-2212 / 3012F/ EVO-2224 / 4024 / 4248SP.

SECTION 4 | Parameter Setup

4.8.2 Description of Parameters Under Group 5 – OTHER FUNCTION

4.8.2.1 POWER SAVING *(Table 4.9, Parameter Setup Screen No.1)*



For more information on use and application of Power Save Functions, *please refer to the following manuals:*

- (i) Sections 4.6.3 and 4.6.4 in Combined Owner's Manual for EVO-1212F / 1212F-HW / 1224F / 1224F-HW
- (ii) Sections 4.8.3 and 4.8.4 in Combined Owner's Manuals for (i) EVO-2212 / 3012 / 2224 / 4024 and (ii) EVO-2212E / 3012E / 2224E / 4024E
- (iii) Sections 4.8.3 and 4.8.4 in Owner's Manual for EVO-4248SP

Parameter "POWER SAVING" is used to enable or disable Power Saving Mode when in "Inverting Mode".

4.8.2.1.1 Programming Steps for Parameter "POWER SAVING"

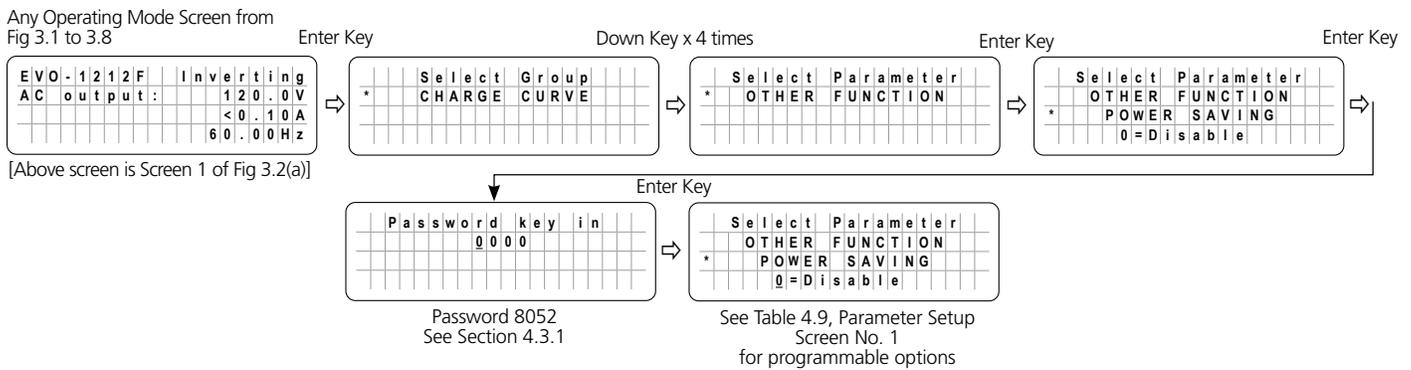

4.8.2.2 ENTER POINT *(Table 4.9, Parameter Setup Screen No.2)*



For more information on use and application of Power Save Functions, *please refer to the following manuals:*

- (i) Sections 4.6.3 and 4.6.4 in Combined Owner's Manual for EVO-1212F / 1212F-HW / 1224F / 1224F-HW
- (ii) Sections 4.8.3 and 4.8.4 in Combined Owner's Manuals for (i) EVO-2212 / 3012 / 2224 / 4024 and (ii) EVO-2212E / 3012E / 2224E / 4024E
- (iii) Sections 4.8.3 and 4.8.4 in Owner's Manual for EVO-4248SP

SECTION 4 | Parameter Setup

If the value of power drawn by AC load falls to the "ENTER POINT" value for 5 sec, the unit will enter "Power Save Mode".

4.8.2.2.1 Programming Steps for Parameter "ENTER POINT"

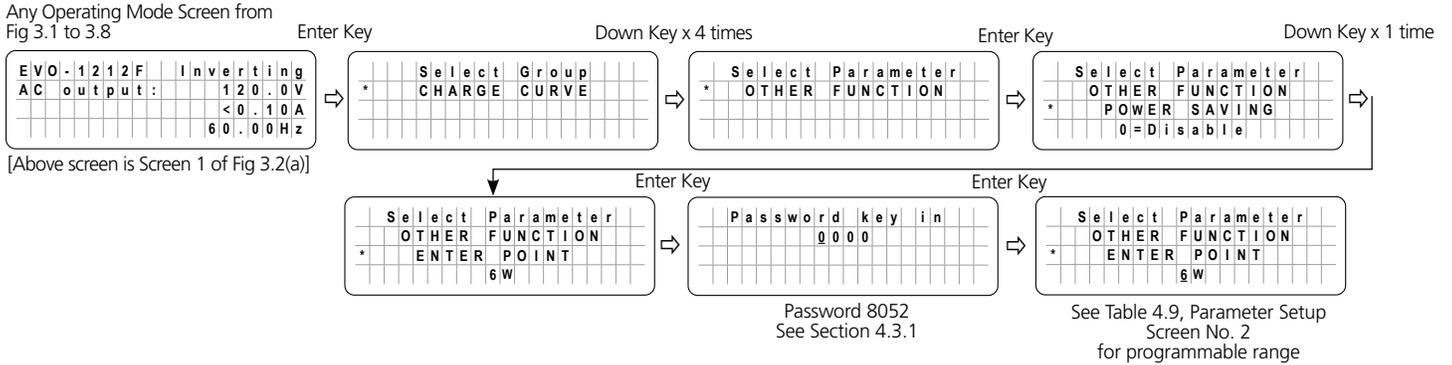

4.8.2.3 WAKE UP POINT (Table 4.9, Parameter Setup Screen No.3)



For more information on use and application of Power Save Functions, please refer to the following manuals:

- (i) Sections 4.6.3 and 4.6.4 in Combined Owner's Manual for EVO-1212F / 1212F-HW / 1224F / 1224F-HW
- (ii) Sections 4.8.3 and 4.8.4 in Combined Owner's Manuals for (i) EVO-2212 / 3012 / 2224 / 4024 and (ii) EVO-2212E / 3012E / 2224E / 4024E
- (iii) Sections 4.8.3 and 4.8.4 in Owner's Manual for EVO-4248SP

If the unit is in "Power Save Mode" and the value of the AC power of the load rises to "WAKE UP POINT", the unit will quit "Power Save Mode" and will start operating in full voltage "Inverting Mode".

4.8.2.3.1 Programming Steps for Parameter "WAKE UP POINT"

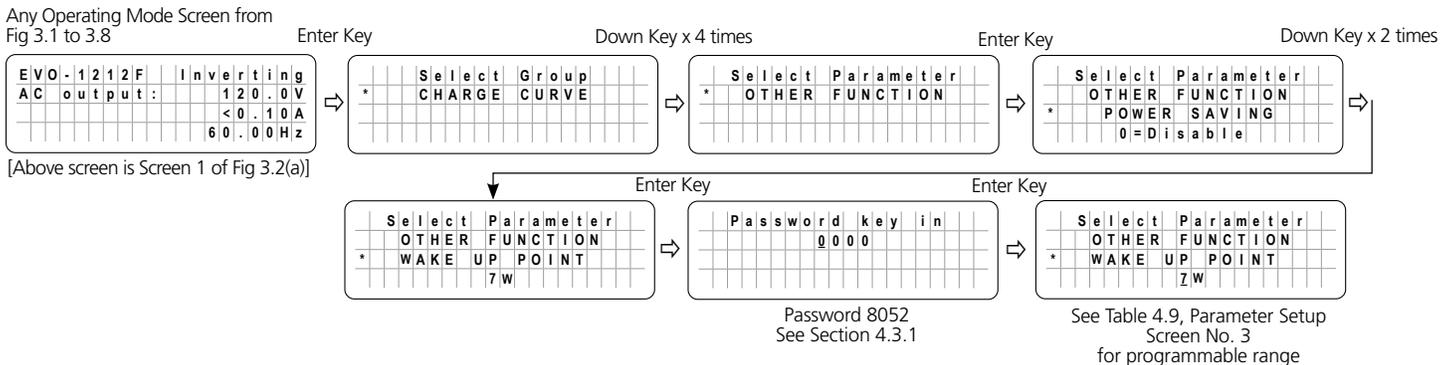

4.8.2.4 REMOTE SWITCH (Table 4.9, Parameter Setup Screen No. 4)

This selection is used when ON/OFF control of EVO™ Inverter/Charger is desired through external 12 VDC signal fed to the terminals marked "Remote ON/OFF" on the Front Panel of EVO™ Inverter/Charger [(i) 15, Fig 2.1 in the combined Owner's Manuals for (a) EVO-2212 / 3012 / 2224 / 4024 and (b) EVO-2212E / 3012E / 2224E / 4024E, (ii) 16, Fig 2.1 in the combined Owner's Manual for EVO-1212F/1212F-HW and EVO-1224F/1224-HW and, (iii) 15, Fig 2.1 in the Owner's Manual for EVO-4248SP].

SECTION 4 | Parameter Setup

On/Off Logic Diagram is shown in Fig 4.8 below:

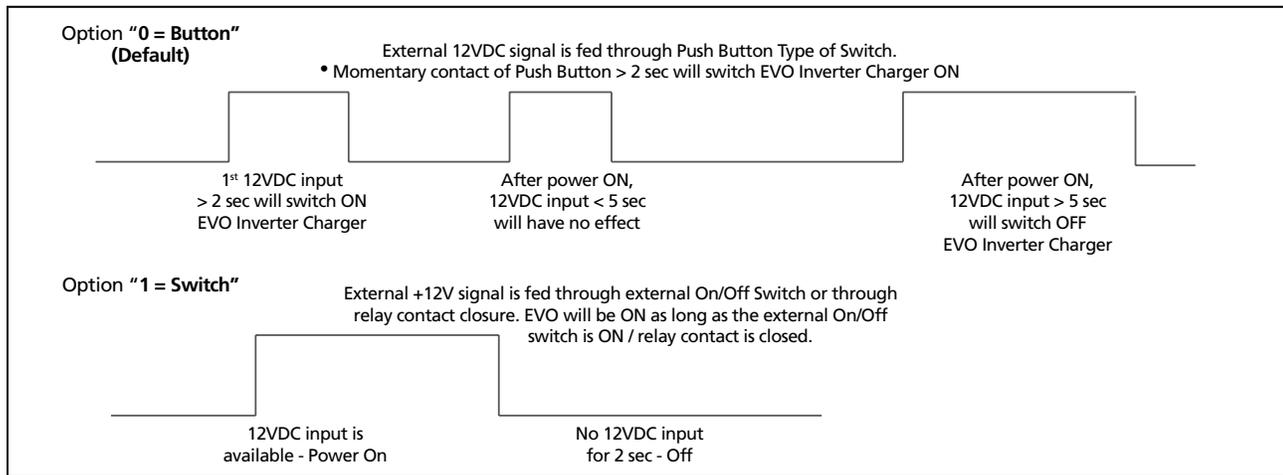

Fig 4.8. On/Off Logic Diagram for Remote Switch Options



CAUTION!

1. On/Off Logic shown in Fig 4.8 also controls the operation of the On/Off Button on the front panel of EVO™ Inverter/Charger (11, Fig 2.1 in EVO™ Inverter/Charger Owner's Manual). The Default Setting is "0 = Button".
2. If the On/Off control is changed to external "Remote Switch", it will not be possible to switch On/Off the EVO™ Inverter/Charger from the front panel On/Off Push Button because it will work with Switch Type Logic at Fig 4.8: it will be ON only as long as the Push Button is kept pressed and will switch off when released.



ATTENTION!

1. Logique On / Off montré dans la figure 4,8 contrôle également le fonctionnement du bouton ON/OFF sur le panneau d'avant de l'onduleur chargeur de l' EVO™ (11 , figure 2,1 dans le manuel d'EVO™ onduleur chargeur propriétaire) . Le réglage par défaut est « Button Type ».
2. Si la commande de On / Off externe est changé en « l'interrupteur à distance », il ne sera pas possible d'activer / désactiver l'onduleur/chargeur EVO™ à partir du panneau avant sur le bouton-poussoir On / Off qu'il travaillera avec le type de commutateur logique à Fig 4.8 : il sera sur qu'aussi longtemps que le bouton est maintenu enfoncé et s'éteint lorsqu'il est relâché.

SECTION 4 | Parameter Setup

b) Option "1 = Normal/Fault": When in "Normal" operational state i.e. when not in Fault Mode, the Status Relay will be OFF (*de-energized*) [(i) "Common" and "NO" contacts will be in open condition and (ii) "Common" and "NC" contacts will be in closed condition]. When the EVO™ Inverter/Charger is in "Fault" mode (*Table 7.1*), the Status Relay will be ON (energized) [(i) Common and "NO" contacts will close and (ii) "Common" and "NC" contacts will open].



INFO

A 12V, 100mA capacity DC source has been provided in (i) EVO-2212/ 3012/ 2224/ 4024, (ii) EVO-2212E/ 3012E/ 2224E/ 4024E and (iii) EVO-4248SP (*16 in Fig 2.1 of Owners Manuals for these models*). This 12V DC source may be used to drive 12V rated signalling device through the contacts of the Status Relay for the above 2 options (*Options 0 & 1*).

4.8.2.5.2 Automatic Starting and Stopping of Generator (Options 2, 3 and 4)

NOTE: *Applicable ONLY for Models (i) EVO-2212 / 3012 / 2224 / 4024, (ii) EVO-2212E / 3012E / 2224E / 4024E & (iii) EVO-4248SP.*

The Normally Open "NO" and "Common" contacts of Status Relay (*14, Fig 2.1 in the Owner's Manuals for (i) EVO-2212 / 3012 / 2224 / 4024, (ii) EVO-2212E / 3012E / 2224E / 4024E & (iii) EVO-4248SP*) can be used to also automatically start and stop generator through appropriate external Generator Auto Start / Stop Module. 3 options (*Options 2, 3 and 4 - See Sections 4.8.2.5.2.1 to 4.8.2.5.2.3*) explained below are available for carrying out this function depending upon user requirements. The "Common" and "NO" terminals are wired to the optional Generator Auto Start / Stop Control Module which, in turn, is wired to the Remote Start / Stop connections on the Generator. The AC output terminals of the Generator are wired either to the Generator Input Terminals on EVO-2212 / 2212E / 3012 / 3012E / 2224 / 2224E / 4024 / 4024E (*7, 8, 9 in Fig 2.3 in Owner's Manual for (i) EVO-2212 / 3012 / 2224 / 4024 or, (ii) EVO-2212E / 3012E / 2224E / 4024E,*) or, to the AC input terminals of EVO-4248SP (*2,3,4,8A in Fig 2.3 in the Owner's Manual for EVO-4248SP*). For installation details, please refer to (i) Section 3.17 / Fig 3.14 and Section 3.18 / Figs 3.15A & B in the Owner's Manuals for (i) EVO-2212 / 3012 / 2224 / 4024 or, (ii) EVO-2212E / 3012E / 2224E / 4024E and (iii) Section 3.17 / Fig 3.13 in the Owner's Manual for EVO-4248SP.



INFO

It is recommended that "GSCM-Mini" Series of Generator Start / Stop Control Module, appropriate for the generator may be considered and ordered directly from Atkinson Electronics www.atkinsonelectronics.com.

Based on the Generator Start Logic contained in of one of the selected Options 2, 3 or 4 explained below (*See Sections 4.8.2.5.2.1 to 4.8.2.5.2.3*), the Status Relay will be switched ON (*energized*), its "Common" and "NO" contacts will close and the external Generator Start / Stop Control Module will initiate automatic starting of the Generator. Once the Generator has started and starts feeding AC output to EVO™ (*within the programmed limits of voltage and frequency*), the EVO™ will be synchronized with the Generator and once synchronization is completed, the load will be transferred instantly (*within 1 ms*) to the Generator at Zero Crossing of the voltage waveform for seamless transfer and for better protection of Transfer Relay contacts. The EVO™ will now operate in "Charging Mode" with the AC power from the Generator charging the batteries as well as providing power to the AC load(s).

Based on the Generator Stop Logic contained in one of the selected Options 2, 3 or 4 explained below (*See Sections 4.8.2.5.2.1 to 4.8.2.5.2.3*), the Status Relay will be switched OFF (*de-energized*), its "Common" and "NO" contacts will open and the external Generator Auto Start Control Control Module will initiate automatic stopping of the Generator. When AC output of the generator is shut down, the EVO™ will automatically transfer the AC load(s) to the "Inverter Section" within 16 ms.

Options 2, 3 and 4 of Parameter "RELAY FUNCTION" related to automatic starting and stopping of generator are explained under Sections 4.8.2.5.2.1 to 4.8.2.5.2.3.

SECTION 4 | Parameter Setup

4.8.2.5.2.1 Option 2 = Generator 0 (This is the Default Option):

This Option will start the Generator at "LOW VOLT ALARM" ([Section 4.4.2.8](#)) and stop the Generator when the batteries are charged based on Charging Profile selected through programming parameter "CHARGING PROFILE" ([Section 4.4.2.21](#)). Further details are given below:

- If the battery voltage drops to "LOW VOLT ALARM" ([Section 4.4.2.8](#)) for continuous period = "GS DETECT TIME" ([Section 4.4.2.16](#)), the Status Relay will be energized. "Common" and "NO" contacts of the Status Relay will close to initiate automatic starting of the Generator.
- Once the generator has started and starts feeding AC output (within the programmed limits of voltage and frequency), the EVO™ will change over from "Inverting Mode" to "Charging Mode". Battery charging will be initiated as per the Charging Profile set through parameter "CHARGING PROFILE" ([Section 4.4.2.21](#))
- Charging will be carried out till the batteries are charged as follows and then, the Status Relay will be de-energized to stop the generator:
 - For Parameter "CHARGING PROFILE" (Section 4.4.2.21) set for 3 Stage Charging Profile as per (i) Option "0 = 3 Stg Adaptive", (ii) Option "1 = 3 Stage Type 1" and (iii) Option "2 = 3 Stage Type 2"
 - The Status Relay will be de-energized to stop the Generator as soon as the battery bank is charged to the voltage threshold set by parameter "FLOATING VOLTAGE" ([Section 4.4.2.4](#))
 - For Parameter "CHARGING PROFILE" (Section 4.4.2.21) set for 2 Stage Charging Profile as per Option "3 = 2 Stage Type 1"
 - The Status Relay will be de-energized to stop the Generator when the battery bank is charged to voltage threshold set by parameter "ABSORP VOLTAGE" ([Section 4.4.2.2](#)) and remains at this level for time period set by parameter "ABSORP TIME" ([Section 4.4.2.19](#))
 - For Parameter "CHARGING PROFILE" (Section 4.4.2.21) set for 2 Stage Charging Profile as per Option "4 = 2 Stage Type 2"
 - The Status Relay will be de-energized to stop the Generator when the battery bank is charged to voltage threshold set by parameter "ABSORP VOLTAGE" ([Section 4.4.2.2](#)) and remains at this level for time period of 6 min
 - For Parameter "CHARGING PROFILE" (Section 4.4.2.21) set for 2 Stage Charging Profile as per Option "5 = 2 Stage Type 3"
 - The Status Relay will be de-energized to stop the Generator when the battery bank is charged to voltage threshold set by parameter "ABSORP VOLTAGE" ([Section 4.4.2.2](#)) and subsequently, the charging current drops to threshold set by parameter "ABSORP EXIT AMPS" ([Section 4.4.2.20](#))

When the Status Relay is de-energized, "Common" and "NO" contacts of the Status Relay will open to initiate automatic stopping of the Generator. When AC output voltage from the Generator switches off, the EVO™ will change over to "Inverting Mode".

SECTION 4 | Parameter Setup

4.8.2.5.2.2 Option 3 = Generator 1

This Option will start the Generator at "LOW VOLT ALARM" ([Section 4.4.2.8](#)) and stop the Generator when the batteries are charged to the desired programmed level of "RESET VOLTAGE" ([Section 4.4.2.7](#)) and stay at this desired level of voltage or higher for the desired programmed time period = "GEN OFF DELAY" ([Section 4.4.2.18](#)). Further details are given below:

- If the battery voltage drops to "LOW VOLT ALARM" ([Section 4.4.2.8](#)) or lower for continuous period = "GS DETECT TIME" ([Section 4.4.2.16](#)), the Status Relay will be switched ON (*energized*). "Common" and "NO" contacts of the Status Relay will close to initiate automatic starting of the Generator.
- Once the generator has started and starts feeding AC output (*within the programmed limits of voltage and frequency*), the EVO™ will change over from "Inverting Mode" to "Charging Mode". Battery charging will be initiated as per Charging Profile set by parameter "CHARGING PROFILE" ([Section 4.4.2.21](#)).
- When the batteries are charged to the desired programmed level of voltage = "RESET VOLTAGE" ([Section 4.4.2.7](#)) and stay at this desired level of voltage, or higher for the desired programmed time period = "GEN OFF DELAY" ([Section 4.4.2.18](#)), the Status Relay will be switched OFF (*de-energized*). "Common" and "NO" contacts of the Status Relay will open to initiate automatic stopping of the Generator. When AC output from the Generator switches OFF, EVO™ will change over to "Inverting Mode" (**NOTE: *The State of Charge of the battery after the Status Relay has been switched OFF (de-energized) and Generator is stopped will be indeterminate***).

4.8.2.5.2.3 Option 4 = Generator 2

This Option will start the Generator at "LOW VOLT ALARM" ([Section 4.4.2.8](#)) and stop the Generator after the desired programmed value of run time of the Generator = "GEN ON TIME" ([Section 4.4.2.17](#)) counted from the time the Status Relay is switched ON (*energized*). Further details are given below:

- If the battery voltage drops to "LOW VOLT ALARM" ([Section 4.4.2.8](#)) or lower for continuous period = "GS DETECT TIME" ([Section 4.4.2.16](#)), the Status Relay will be switched ON (*energized*). "Common" and "NO" contacts of the Status Relay will close to initiate automatic starting of the Generator.
- Once the generator has started and starts feeding AC output (*within the programmed limits of voltage and frequency*), the EVO™ will change over from "Inverting Mode" to "Charging Mode". Battery charging will be initiated as per the Charging Profile set by parameter "CHARGING PROFILE" ([Section 4.4.2.21](#)).
- The Status Relay will be switched OFF (*de-energized*) after expiry of the desired programmed Generator run time = "GEN ON TIME" ([Section 4.4.2.17](#)) counted from the time the Status Relay is switched ON (*energized*). "Common" and "NO" contacts of the Status Relay will open to initiate automatic stopping of the Generator. When AC output from the Generator switches OFF, EVO™ will change over to "Inverting Mode" (**NOTE: *The State of Charge of the battery after the Status Relay has been switched OFF (de-energized) and Generator is stopped will be indeterminate***).

SECTION 4 | Parameter Setup

4.8.2.5.3 Programming Steps for Parameter "RELAY FUNCTION"

Diagram showing steps for programming the above RELAY FUNCTION is given below:

NOTE: *This parameter is available only for (i) EVO-2212 / 3012 / 2224 / 4024, (ii) EVO-2212E / 3012E / 2224E / 4024E and (iii) EVO-4248SP*

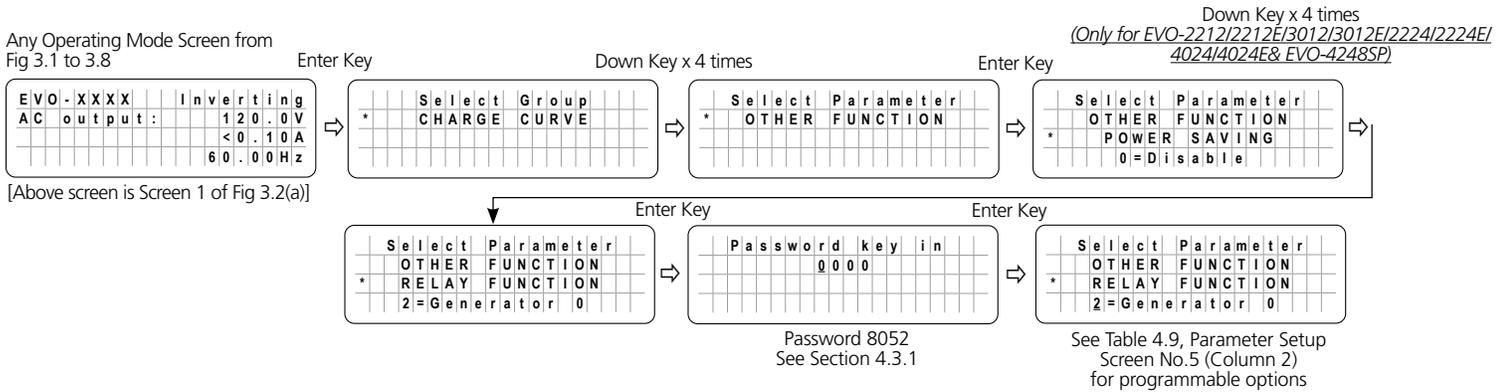

4.8.2.6 COMM ID (Table 4.9, (i) Parameter Setup Screen No. 5 under Column 1 (ii) Parameter Setup Screen No. 6 under Column 2)

Parameter "COMM ID" (*Communication ID*) sets the ID number for the COMM Port and EVO-RC-PLUS Remote Control.

4.8.2.6.1 Programming Steps for Parameter "COMM ID"

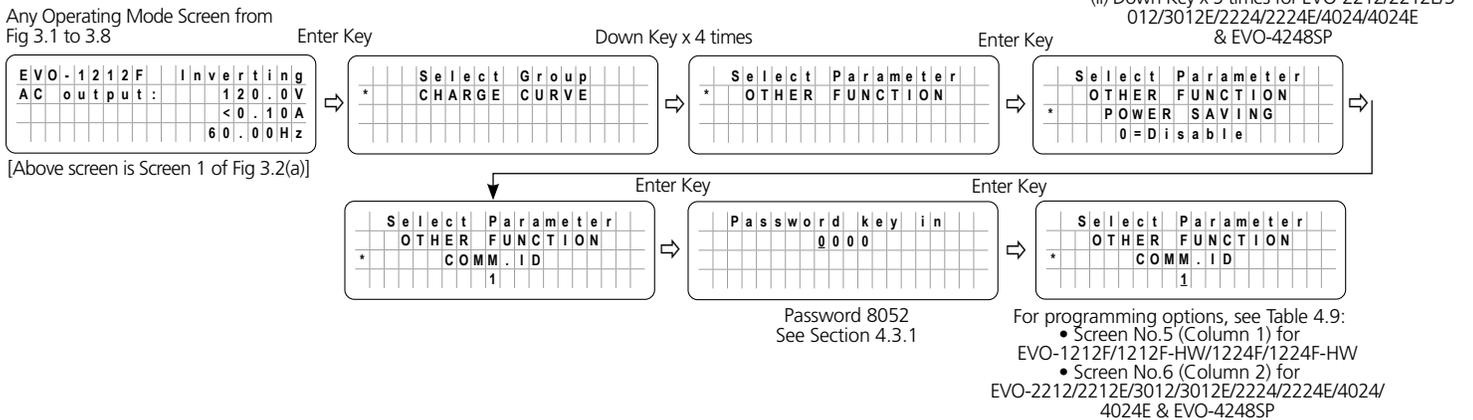

4.8.2.7 BUZZER

(Table 4.9, (i) Parameter Setup Screen No. 6 under Column 1 (ii) Parameter Setup Screen No. 7 under Column 2)

An audio alarm buzzer is located inside the EVO™ Inverter/Charger to provide pulsing or continuously beeping alarm based on operating conditions detailed in Table 6.1 under Section 6.

SECTION 4 | Parameter Setup

Parameter "BUZZER" provides option to switch on/ switch off the buzzer. The default option is "1=On".

4.8.2.7.1 Programming Steps for Parameter "BUZZER"

Any Operating Mode Screen from Fig 3.1 to 3.8

EVO-1212F	Inverting
AC output:	120.0V
	<0.10A
	60.00Hz

[Above screen is Screen 1 of Fig 3.2(a)]

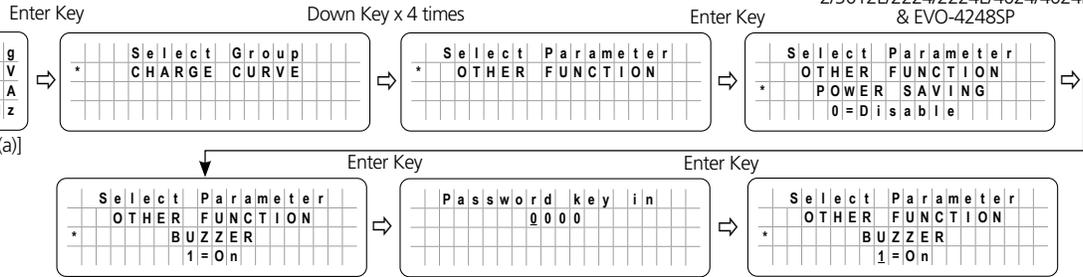

Password 8052
See Section 4.3.1

- (i) Down Key x 5 times for EVO-1212F/1212F-HW/1224F/1224F-HW
- (ii) Down Key x 6 times for EVO-2212E/2212E/3012/3012E/2224/2224E/4024/4024E & EVO-4248SP

For programming options, see Table 4.9:
 • Screen No.6 (Column 1) for EVO-1212F/1212F-HW/1224F/1224F-HW
 • Screen No.7 (Column 2) for EVO-2212E/2212E/3012/3012E/2224/2224E/4024/4024E & EVO-4248SP

4.8.2.8 DISCHARGE BEEP

(Table 4.9, (i) Parameter Setup Screen No. 7 under Column 1 (ii) Parameter Setup Screen No. 8 under Column 2)

When EVO™ Inverter/Charger is operating in "Inverting Mode", the batteries will be discharging. An audio alarm buzzer has been provided inside the EVO™ Inverter/Charger that will provide pulsing beep once every 3 sec to signal discharging of batteries under "Inverting Mode" (Refer to Table 6.1 in Section 6).

Parameter "DISCHARGE BEEP" provides option to switch on/ switch off this alarm signalling. The default option is "1=On".

NOTE: If parameter "BUZZER" (Section 4.8.2.7) is set for option "0=Off", the operation of the buzzer will be switched off and there will be no discharge beeping even if parameter "DISCHARGE BEEP" has been set for option "1=On".

4.8.2.8.1 Programming Steps for Parameter "DISCHARGE BEEP"

Any Operating Mode Screen from Fig 3.1 to 3.8

EVO-1212F	Inverting
AC output:	120.0V
	<0.10A
	60.00Hz

[Above screen is Screen 1 of Fig 3.2(a)]

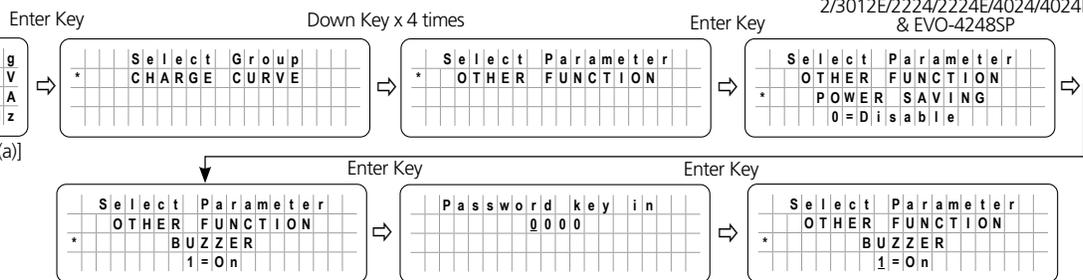

Password 8052
See Section 4.3.1

- (i) Down Key x 6 times for EVO-1212F/1212F-HW/1224F/1224F-HW
- (ii) Down Key x 7 times for EVO-2212E/2212E/3012/3012E/2224/2224E/4024/4024E & EVO-4248SP

For programming options, see Table 4.9:
 • Screen No.7 (Column 1) for EVO-1212F/1212F-HW/1224F/1224F-HW
 • Screen No.8 (Column 2) for EVO-2212E/2212E/3012/3012E/2224/2224E/4024/4024E & EVO-4248SP

4.8.2.9 DEFAULT RESET

(Table 4.9, (i) Parameter Setup Screen No. 8 under Column 1 (ii) Parameter Setup Screen No. 9 under Column 2)

This is to reset all of the parameters to the Default Values.

SECTION 4 | Parameter Setup

4.8.2.9.1 Programming Steps for Parameter "DEFAULT RESET"

Any Operating Mode Screen from Fig 3.1 to 3.8

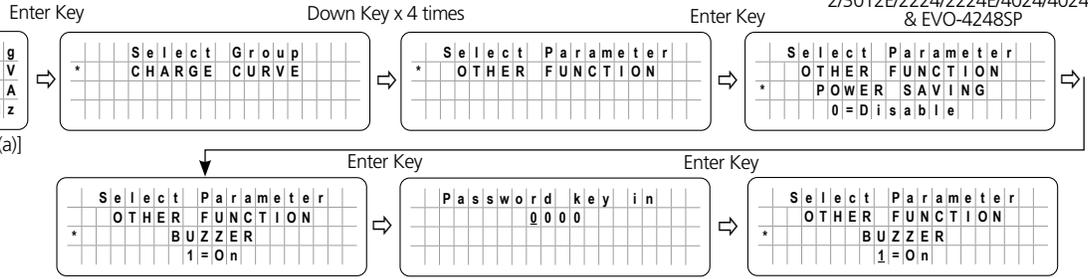
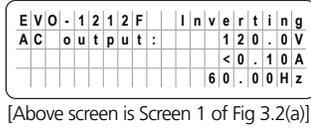

Password 8052
See Section 4.3.1

- (i) Down Key x 7 times for EVO-1212F/1212F-HW/1224F/1224F-HW
 - (ii) Down Key x 8 times for EVO-2212/2212E/3012/3012E/2224/2224E/4024/4024E & EVO-4248SP
- For programming options, see Table 4.9:
- Screen No.8 (Column 1) for EVO-1212F/1212F-HW/1224F/1224F-HW
 - Screen No.9 (Column 2) for EVO-2212/2212E/3012/3012E/2224/2224E/4024/4024E & EVO-4248SP

4.8.2.10 DATALOG TIME AND DATALOG DISABLE

(Table 4.9, (i) Parameter Setup Screen No. 9 under Column 1 (ii) Parameter Setup Screen No. 10 under Column 2)

Refer to Sections 5.2 to 5.3 on Data Logging.

Data Logging uses external SD Card (*FAT 16/32, up to 32 GB capacity*) to record the values of various Operating Parameters /Events/Errors with Date and Time stamp controlled by an internal Real Time Clock (*RTC*). Parameters/Events/Errors are recorded under "Data Logging Fields" (*Section 5.2.2 for information on Data Logging Fields for various EVO™ Models*)

The recorded values of the various Operating Parameters are their "Average Values" computed from "Instantaneous Values" scanned over a programmable "time interval" set by programming parameter "DATALOG TIME". Events/Errors are recorded as soon as they are sensed.

Apart from providing 6 options for setting the "time interval" for computing the "Average Values", programming parameter "DATALOG TIME" is also used to disable Data Logging by selecting programming option "0=Disable"

Programming Options (i) 0=Disable, (ii) 1=1 sec (Default), (iii) 2=10 sec, (iv) 3=30 sec, (v) 4=60 sec, (vi) 5=5 min, (vii) 6=10 min

4.8.2.10.1 Programming Steps for Parameter "DATALOG TIME"

Any Operating Mode Screen from Fig 3.1 to 3.8

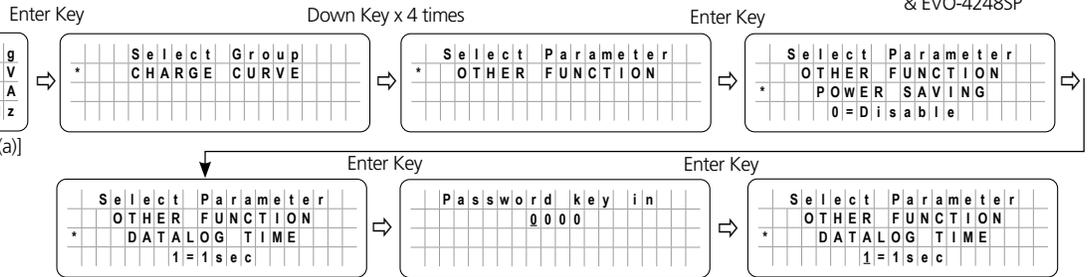
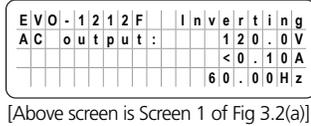

Password 8052
See Section 4.3.1

- (i) Down Key x 8 times for EVO-1212F/1212F-HW/1224F/1224F-HW
 - (ii) Down Key x 9 times for EVO-2212/2212E/3012/3012E/2224/2224E/4024/4024E & EVO-4248SP
- For programming options, see Table 4.9:
- Screen No.9 (Column 1) for EVO-1212F/1212F-HW/1224F/1224F-HW
 - Screen No.10 (Column 2) for EVO-2212/2212E/3012/3012E/2224/2224E/4024/4024E & EVO-4248SP

SECTION 4 | Parameter Setup

4.8.2.11 PARAMETER SAVE

(Table 4.9, (i) Parameter Setup Screen No. 10 under Column 1 (ii) Parameter Setup Screen No. 11 under Column 2)

Save all parameters to SD Card. (See Details at Section 5.4)

4.8.2.11.1 Programming Steps for Parameter "PARAMETER SAVE"

Any Operating Mode Screen from Fig 3.1 to 3.8

EVO-1212F	Inverting
AC output:	120.0V
	<0.10A
	60.00Hz

[Above screen is Screen 1 of Fig 3.2(a)]

Enter Key

Select Group	* CHARGE CURVE
--------------	----------------

Down Key x 4 times

Select Parameter	* OTHER FUNCTION
------------------	------------------

Enter Key

Select Parameter	* OTHER FUNCTION
	POWER SAVING
	0=Disable

Select Parameter	* OTHER FUNCTION
	PARAMETER SAVE
	0=No

Enter Key

Password key in	0000
-----------------	------

Password 8052
See Section 4.3.1

Enter Key

Select Parameter	* OTHER FUNCTION
	PARAMETER SAVE
	0=No

For programming options, see Table 4.9:
 • Screen No. 10 (Column 1) for EVO-1212F/1212F-HW/1224F/1224F-HW
 • Screen No. 11 (Column 2) for EVO-2212/2212E/3012/3012E/2224/2224E/4024/4024E & EVO-4248SP

- (i) Down Key x 9 times for EVO-1212F/1212F-HW/1224F/1224F-HW
- (ii) Down Key x 10 times for EVO-2212/2212E/3012/3012E/2224/2224E/4024/4024E & EVO-4248SP

4.8.2.12 TEMP UNIT

(Table 4.9, (i) Parameter Setup Screen No. 11 under Column 1 (ii) Parameter Setup Screen No. 12 under Column 2)

Temperature display can be selected in °C or °F. Default is in °C.

4.8.2.12.1 Programming Steps for Parameter "TEMP UNIT"

Any Operating Mode Screen from Fig 3.1 to 3.8

EVO-1212F	Inverting
AC output:	120.0V
	<0.10A
	60.00Hz

[Above screen is Screen 1 of Fig 3.2(a)]

Enter Key

Select Group	* CHARGE CURVE
--------------	----------------

Down Key x 4 times

Select Parameter	* OTHER FUNCTION
------------------	------------------

Enter Key

Select Parameter	* OTHER FUNCTION
	POWER SAVING
	0=Disable

Select Parameter	* OTHER FUNCTION
	TEMP UNIT
	0=C

Enter Key

Password key in	0000
-----------------	------

Password 8052
See Section 4.3.1

Enter Key

Select Parameter	* OTHER FUNCTION
	TEMP UNIT
	0=C

For programming options, see Table 4.9:
 • Screen No. 11 (Column 1) for EVO-1212F/1212F-HW/1224F/1224F-HW
 • Screen No. 12 (Column 2) for EVO-2212/2212E/3012/3012E/2224/2224E/4024/4024E & EVO-4248SP

- (i) Down Key x 10 times for EVO-1212F/1212F-HW/1224F/1224F-HW
- (ii) Down Key x 11 times for EVO-2212/2212E/3012/3012E/2224/2224E/4024/4024E & EVO-4248SP

4.8.2.13 PASSWORD DISABLE

(Table 4.9, (i) Parameter Setup Screen No. 12 under Column 1 (ii) Parameter Setup Screen No. 13 under Column 2)

This parameter allows to disable/enable Password (8052) that is required to change the value of any programmable parameter. Use of Password is recommended because it prevents accidental/unintentional change of parameter setting. Default is enabled (PASSWORD DISABLE set at "O=No").

SECTION 4 | Parameter Setup

4.8.2.13.1 Programming Steps for Parameter "PASSWORD DISABLE"

Any Operating Mode Screen from Fig 3.1 to 3.8

[Above screen is Screen 1 of Fig 3.2(a)]

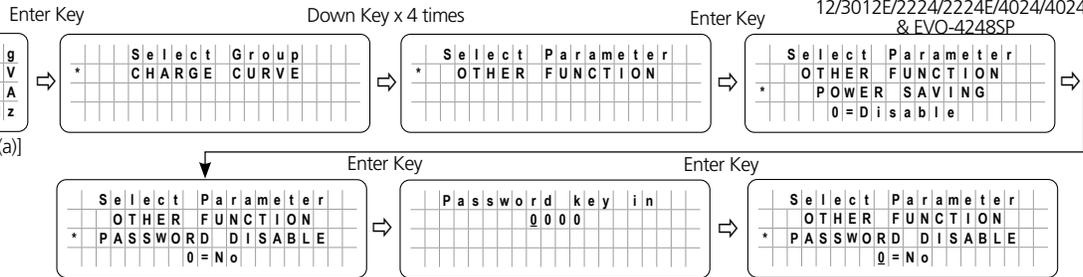

Password 8052
See Section 4.3.1

- (i) Down Key x 11 times for EVO-1212F/1212F-HW/1224F/1224F-HW
- (ii) Down Key x 12 times for EVO-2212/2212E/3012/3012E/2224/2224E/4024/4024E & EVO-4248SP

For programming options, see Table 4.9:
 • Screen No.12 (Column 1) for EVO-1212F/1212F-HW/1224F/1224F-HW
 • Screen No.13 (Column 2) for EVO-2212/2212E/3012/3012E/2224/2224E/4024/4024E & EVO-4248SP

4.9 GROUP 6 PARAMETER SET UP: RC-PLUS SETTING

4.9.1 Programming Ranges and Default/ Factory Preset Values of Parameters Under Group 6 – RC-PLUS SETTING

Table 4.10 below gives details of programming ranges and default values of parameters under Parameter Group 6 - RC-PLUS SETTING. Refer to Fig 4.5 under Section 4.1.3.4 for Menu Map for navigating through various parameters under this Group 6.

These parameters are used to control dimming of LCD back lighting of Remote Control EVO-RC-PLUS.

Table 4.10 Group 6 Parameter Set Up: RC-PLUS SETTING (Refer to Menu Map at Fig 4.5, Section 4.1.3.4)

Parameter Setup Screen No. (Column 1)	Parameter (Column 2)	Setting range
		(i) EVO-1212F / 1212F-HW / 1224F / 1224F-HW (ii) EVO-2212 / 2212E / 3012 / 3012E / 2224 / 2224E / 4024 / 4024E (iii) EVO-4248SP (Column 3)
1	ACTIVE LCD LIGHT	0 = 0%, 1 = 25%, 2 = 50%, 3 = 75%, 4 = 100% (Default: 4 = 100%)
2	IDLE LCD LIGHT If any key on the Remote Control EVO-RC-PLUS has not been pressed for time set by parameter "IDLE LCD TIMER", the backlight will dim to the programmed option	0 = 0%, 1 = 25%, 2 = 50%, 3 = 75%, 4 = 100% (Default: 1 = 25%)
3	IDLE LCD TIMER If any key on the Remote Control EVO-RC-PLUS has not been pressed for time set by this parameter, the backlight will dim to the programmed option selected through parameter "IDLE LCD LIGHT"	1 to 60 min. (Default = 5 min)

SECTION 4 | Parameter Setup

4.9.2.3 IDLE LCD TIMER (Table 4.10, Parameter Setup Screen No.3)

During the active operation mode of the LCD display, its level of brightness is controlled by parameter "ACTIVE LCD LIGHT" (Section 4.9.2.1). If any key on the EVO-RC-PLUS Remote Control has not been depressed for time set by this parameter i.e. "IDLE LCD TIMER", the backlight of the LCD screen will be dimmed to the level set by parameter "IDLE LCD LIGHT" (Section 4.9.2.2).

4.9.2.3.1 Programming Steps for Parameter "IDLE LCD TIMER"

Any Operating Mode Screen from Fig 3.1 to 3.8

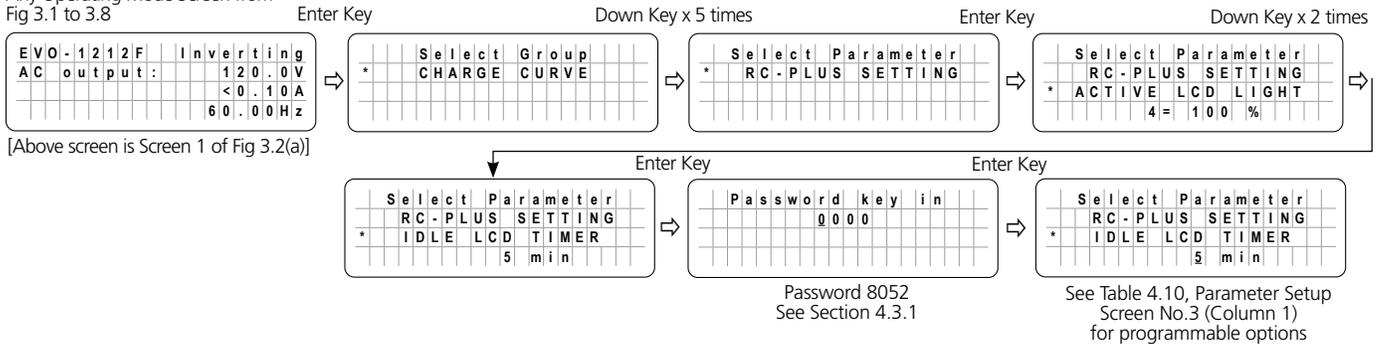

4.10 GROUP 7 PARAMETER SETUP: TIME SETTING

Please refer to Parameter "TIME SETTING" under Screen No. 7 for Group 7 at Fig 4.1 under Section 4.1.2. Set up details are given below. The Date and Time Format is Year/Month/Day Hour:Minute (24 hour clock):

NOTE: Password is not required for setting this parameter.

4.10.1 Programming Steps for Parameter "TIME SETTING"

Any Operating Mode Screen from Fig 3.1 to 3.8

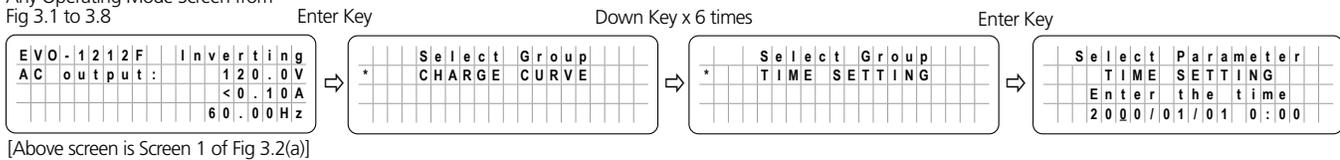

INFO

- Time can be programmed from Year 2000 to 2099 only.
- Month can be programmed from 01 to 12 only.
- Day can be programmed from 01 to 31 only.
- Hour can be programmed from 00 to 24 only.
- Minute can be programmed from 00 to 60 only.
- **If the numbers Entered for Month, Day, Hour and Minute are not within the above ranges, message "OUT OF RANGE!" will be displayed and the display screen will go back to the previously set time. Setting procedure will have to be re-started.**

SECTION 5 | SD Card

5.1 SD CARD GENERAL INFORMATION

SD Card slot has been provided for using an SD card for (i) data logging and (ii) saving programmed parameters. SD card supports FAT16/FAT32 format up to 32GB in size.

When the SD card is inserted, the LCD screen will display the following.

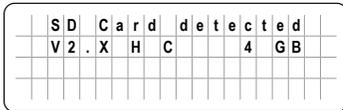

SD card is detected and shows the Version and capacity. "xx" is the capacity.

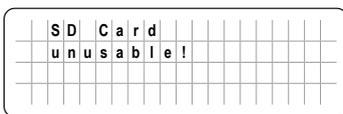

Not supported card.



CAUTION!

Do not remove SD Card when data logging has been enabled (may corrupt files). Follow "STOP SD CARD" procedure (Section 4.11) before removing the SD Card.



ATTENTION!

Ne pas retirer la carte SD lorsque « data loggin » a été activée (peut corrompre les fichiers). Suivez la procédure "STOP SD CARD" (article 4.11) avant de retirer la carte SD .

5.2 DATA LOGGING

5.2.1 General Information

Data Logging uses external SD Card (See Section 5.1 above) to record the values of various Operating Parameters / Events/Errors with Date and Time stamp controlled by an internal Real Time Clock (RTC). **It is, therefore, necessary that before starting data logging, the current Date and Time should be set (if not set already) by using parameter "TIME SETTING" (Section 4.10)**

Operating Parameters/Events/Errors are recorded under "Data Logging Fields" (See Section 5.2.2 for information on Data Logging Fields for various EVO™ Models).

Operating Parameters/Events/Errors are recorded as follows:

- **Operating Parameters:** The recorded values of the various Operating Parameters are their "Average Values" computed from "Instantaneous Values" scanned over a programmable "time interval" set by programming parameter "DATALOG TIME" (Section 4.8.2.10) with options (i) 0=Disable, (ii) 1=1 sec (Default), (iii) 2=10sec, (iv) 3=30sec, (v) 4=60sec, (vi) 5=5min, (vii) 6=10min.
- **Events / Errors:** These are recorded as soon as they are sensed.

SECTION 5 | SD Card

With default setting of parameter "DATALOG TIME" (*Section 4.8.2.10*) set at option "1=1sec", data logging will commence as soon as the SD Card is inserted in the SD Card Slot in the EVO-RC-PLUS Remote Control (*Section 5.2.3*). In case parameter "DATALOG TIME" (*Section 4.8.2.10*) has been set at option "0=Disable", data logging will NOT commence automatically when the SD Card is inserted in the SD Card Slot in the EVO-RC-PLUS Remote Control.

5.2.2 DATA LOGGING Fields

Various Operating Parameters "Error Codes" and "Events" are recorded under DATA LOGGING fields shown in Figs 5.1 to 5.3.

5.2.2.1 DATA LOGGING Fields for Models EVO-1212F / 1212F-HW / 1224F / 1224F-HW

"DATA LOGGING" Fields for models EVO-1212F/1212F-HW/1224F/1224F-HW are shown in Fig 5.1 below:

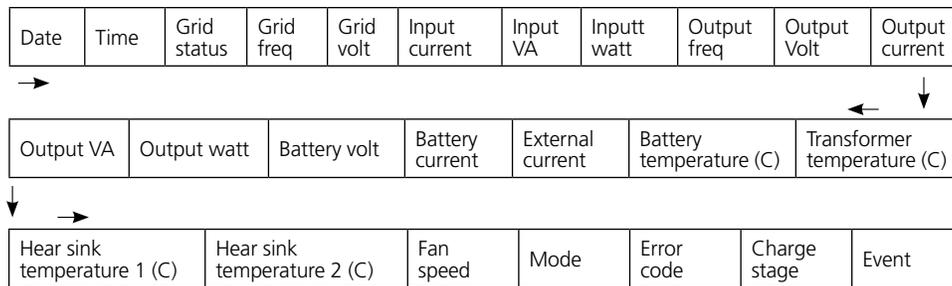

Fig 5.1 Data Logging Fields for EVO-1212F/1212F-HW/1224F/1224F-HW

5.2.2.2 DATA LOGGING Fields for (i) EVO-2212 / 3012 / 2224 / 4024 & (ii) EVO-2212E / 3012E / 2224E / 4024E

"DATA LOGGING" Fields for models: (i) EVO-2212 / 3012 / 2224 / 4024 & (ii) EVO-2212E / 3012E / 2224E / 4024E are shown in Fig 5.2 below:

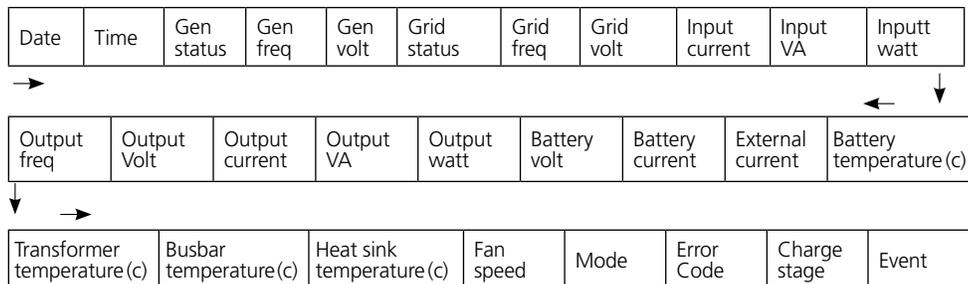

Fig 5.2 Data Logging Fields for (i) EVO-2212 / 3012 / 2224 / 4024 & (ii) EVO-2212E / 3012E / 2224E / 4024E

SECTION 5 | SD Card

5.2.2.3 DATA LOGGING Fields for Model EVO-4248SP

"DATA LOGGING" Fields for model EVO-4248SP are shown in Fig 5.3 below:

Date	Time	Grid status	Grid freq	Input Amp 1	Input Amp 2	Input VA 1	Input VA 2	Input watt 1	Input watt 2	Output freq	
External Amp	Battery Amp	Battery volt	Output watt 2	Output watt 1	Output VA 2	Output VA 1	Output Amp 2	Output Amp 1	Output volt		
Battery (c)	Transformer (c)	Heat sink 1(c)	Heat sink 2 (c)	Fan speed	Mode	Error code	Charge stage	CAN status	CAN watt	AVG watt	Event

Fig 5.3 Data Logging Fields for EVO-4248SP

The Data Logging Fields in Figs 5.1 to 5.3 above show the average value over one of the 6 time interval options shown below under programming parameter "DATALOG TIME" (See Section 4.8.2.10). Default time interval is 1 sec (Option "1=1 sec"). Parameter "DATALOG TIME" is also used to disable data logging (Option 0=Disable). Interval / disabling options are shown below:

- 0=Disable ; 1=1 sec (Default) ; 2=10 sec ; 3=30 sec ; 4=60 sec ; 5=5 min ; 6=10 min

NOTE: Data Logging Fields "Error Code" and "Event" shown in Figs 5.1 to 5.3 above record "Error Code"/"Event" *as soon as they occur*

5.2.3 Operating Screens when SD Card is Inserted for Data Logging

Data logging will be carried out automatically as soon as the SD Card is inserted in the SD Card Slot of EVO-RC-PLUS. [Provided parameter "DATALOG TIME" (Section 4.8.2.10) has NOT been set to "0 = Disable").

Operating screens are shown below:

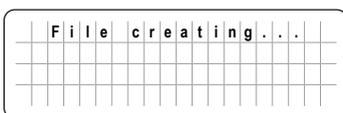

Data log function has been initiated and new file is being created. Do not remove the SD card when file creating is displayed.

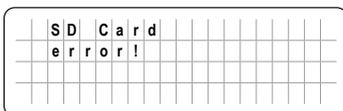

Read error, the data log function/update/upload will stop.

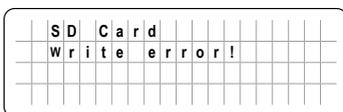

Write error. The Data logging function will stop.

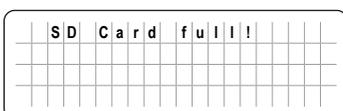

1. Card full. Data logging function has stopped.
2. There is not enough space to create Data Log File Folder or to save file with saved programmed parameters.

NOTE: *Once there is enough space to create a Data Log File Folder and subsequently, it runs out of capacity due to recording newer data, it will start to overwrite on older files.*

SECTION 5 | SD Card

5.2.4 Disabling Data Logging

In the factory default condition, data logging has been enabled at 1 sec recording interval [*Parameter "DATALOG TIME" (Section 4.8.2.10) has been set to option "1=1 sec"*]. Hence, data logging will commence as soon as SD Card is inserted.

To *disable data logging*, parameter "DATALOG TIME" (*Section 4.8.2.10*) has to be set at option "0=Disable".

5.3 DATA LOG FILES AND VIEWING DATA LOG FILES USING MICROSOFT EXCEL

5.3.1 Data Log Files are written as De-limited Text Files (.txt) in the DATALOG Folder on the SD Card's Root Directory. *Table 5.1* is an image of the DATALOG Folder showing example of the De-limited Data Log Files. The File Name Format is month/day/hour/minute.txt (*MMDDhhmm.txt*). Each file has 512 rows of records. (*Each row has multiple data fields as described at Section 5.2.2*). **Each file size is 128kb.**

Name	Date modified	Type	Size
 07160007.txt	2018-07-25 12:13 PM	Text Document	128 KB
 07160016.txt	2018-07-25 12:13 PM	Text Document	128 KB
 07160024.txt	2018-07-25 12:13 PM	Text Document	128 KB
 07160033.txt	2018-07-25 12:13 PM	Text Document	128 KB
 07160041.txt	2018-07-25 12:13 PM	Text Document	128 KB
 07160050.txt	2018-07-25 12:13 PM	Text Document	128 KB
 07160058.txt	2018-07-25 12:13 PM	Text Document	128 KB
 07160107.txt	2018-07-25 12:13 PM	Text Document	128 KB
 07160115.txt	2018-07-25 12:13 PM	Text Document	128 KB
 07160124.txt	2018-07-25 12:13 PM	Text Document	128 KB
 07160132.txt	2018-07-25 12:13 PM	Text Document	128 KB
 07160141.txt	2018-07-25 12:13 PM	Text Document	128 KB

5.3.2 *Table 5.2* shows an example of the contents of one of the ".txt" files *opened with a general purpose Text Reader, e.g. Microsoft Notepad*. The 1st Row shows the Model No. (*EVO-4024 in this example*).The 2nd Row shows Data Logging Fields separated by semicolon i.e. ";" (*see details of all the Data Logging Fields for various EVO™ models at Section 5.2.2*). The 3rd Row onwards shows the values/status of the Data Logging Fields at time interval equal to the programming value of programmed parameter DATALOG TIME (*See Section 4.8.2.10*).

NOTE: Data Logging Fields "Error Code" and "Event" will be logged as soon as they occur.

SECTION 5 | SD Card

TABLE 5.2 Example of Data Log Text File "0716007.txt" for Model No. EVO-4024 as seen through Text Editor "Notepad"

07160007.txt - Notepad	
File Edit Format View Help	
EVO-4024	
Date; Time; Gen status; Gen freq; Gen volt; Grid status; Grid freq; Grid volt; Input current; Input VA; Input watt; Output freq; Output volt; Output current; Output VA; Output watt; Battery volt; Battery current; External current; Battery temperature (C); Transformer temperature (C); Bus bar temperature (C); Heat sink temperature (C); Fan speed; Mode; Error Code; Charge Stage; Event. (See NOTE 2)	
2018/07/16; 00:07:51; 33343; 000.00; 000.65; 00000; 059.94; 123.44; 009.18; 01133; 01103; 059.94; 123.55; 008.23; 01015; 01015; 27.734; 0002.7; 0000.0; 0022.8; 0051.8; 0039.2; 0032.0; 0; 2; 0000; 4; (See NOTES 2 and 3)	
2018/07/16; 00:07:52; 33343; 000.00; 000.65; 00000; 059.94; 123.43; 009.23; 01140; 01110; 059.94; 123.52; 008.28; 01022; 01025; 27.694; 0002.7; 0000.0; 0022.8; 0051.8; 0039.2; 0032.0; 0; 2; 0000; 4; (See NOTES 2 and 3)	
2018/07/16; 00:07:53; 33343; 000.00; 000.65; 00000; 059.94; 123.45; 009.28; 01146; 01116; 059.94; 123.55; 000.30; 01024; 01025; 27.694; 0002.7; 0000.0; 0022.8; 0051.8; 0039.2; 0032.0; 0; 2; 0000; 4; (See NOTES 2 and 3)	
NOTES:	
1. Example of data displayed is for 120VAC Model No. EVO-4024.	
2. There are 28 Data Logging Fields for EVO-2212/2212E/3012/3012E/2224/2224E/4024/4024E (Date; Gen status; Gen freq; etc.). In the actual ".txt file", these fields will be displayed across one single horizontal line.	
3. The values of the 28 Data Logging Fields (2018/07/16; 00:07:51; 33343; 000.00; 000.65; etc.) will also be displayed across one single horizontal line.	
4. The 3 lines of values for the 28 Data Logging Fields (2018/07/16; 00:07:51; 33343; 000.00; 000.65; etc.) shown above are the first 3 lines from 512 lines contained in a ".txt" file. The value / status of each of the 512 line is recorded at the default "DATALOG TIME" (Section 4.8.2.10) of 1 sec interval.	

5.3.2.1 Follow procedure given below to open Data Log Files in Microsoft Excel (Version used is 2016):

- Start Microsoft Excel.
- Click File Menu Tab on the top left hand corner.
- Click "Open" from the Drop Down Menu.
- Browse to the Directory where the Data Log Files downloaded from the SD Card are located.
- Click on "File Types" List Box at the bottom right corner (the List Box shows "All Excel Files" as default) and select Text Files from the Drop Down Menu.
- All Text Files (.txt) will be displayed. The screen will look like Fig 5.4.

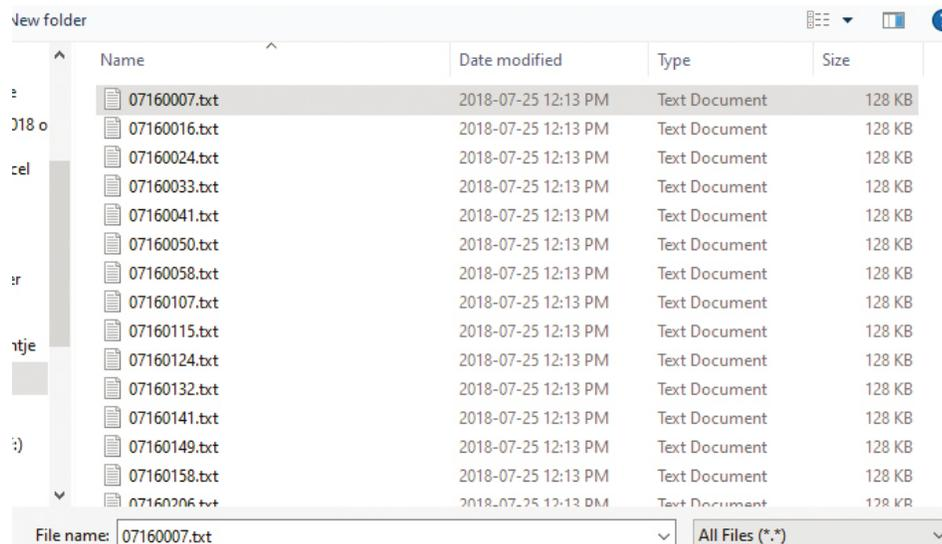

Fig 5.4 Screen Showing ".txt" Files downloaded from SD Card into Computer Directory

SECTION 5 | SD Card

- Click "Open" Button (*Bottom right corner of Fig 5.4*).
- "Text Import Wizard – Step 1 of 3" will be shown (*Fig 5.5*). Choose "Delimited" File Type".

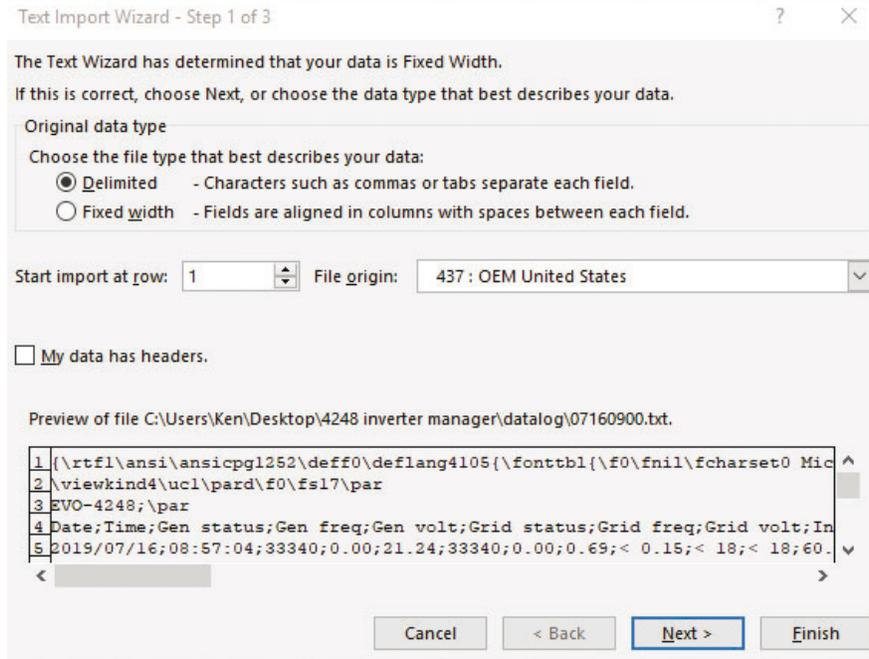

Fig 5.5 Screen showing Step 1 of 3 of "Text Import Wizard" in Excel

- Text Import Wizard – Step 2 will appear (*See Fig 5.6*). Choose "Semicolon" and click 'Finish' button.

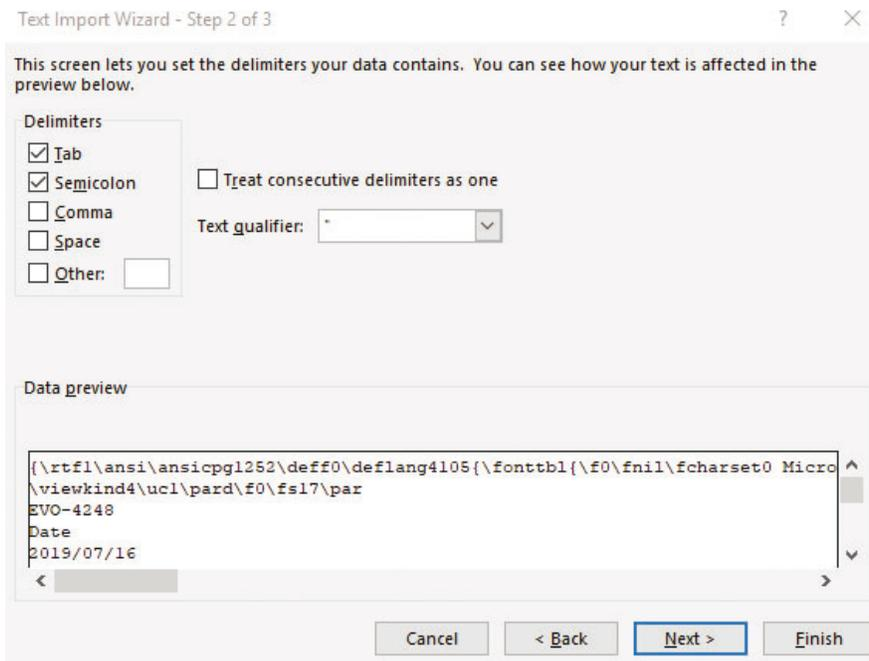

Fig 5.6 Screen showing Step 2 of 3 of "Text Import Wizard" in Excel

SECTION 5 | SD Card

- Data as in Fig 5.7 will be displayed on your Worksheet, with the Log Data stored in Columns and Rows.

Fig 5.7 Screen showing Data Log Work Sheet in Excel

5.4 SAVING / UPLOADING PROGRAMMED PARAMETERS

5.4.1 Saving Programmed Parameters

All the programmed parameters can be saved on an SD Card (*FAT 16 / FAT 32 Format, up to 32 GB capacity*). The parameters will be saved in File named "xxxx_yyy.cfg", where the first group of 4 digits xxx is the Model No. e.g. 1212 or, 2212 or, 2224 or, 3012 or, 4024 or, 4248 and the second group of 3 digits YYY is the Revision No. for that model.

- For saving, first insert the SD Card in the SD Card Slot.
- Then, go to "Parameter Save" Screen (*See Section 4.8.2.11*). Steps are given below at Section 5.4.1.1:

5.4.1.1 Programming Steps for Parameter "PARAMETER SAVE"

Any Operating Mode Screen from Fig 3.1 to 3.8

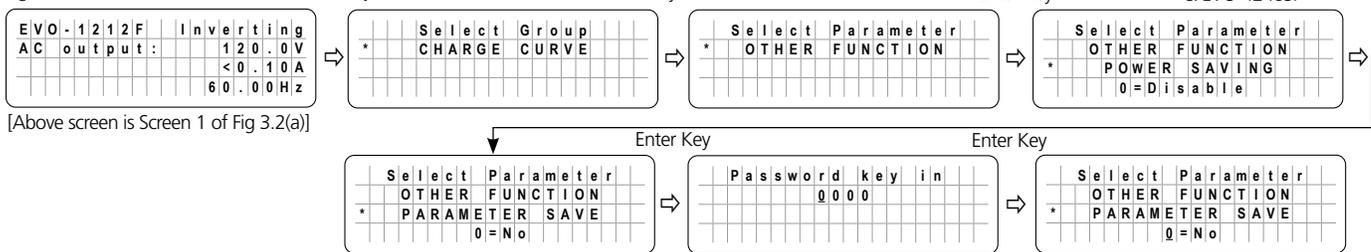

[Above screen is Screen 1 of Fig 3.2(a)]

Password 8052
See Section 4.3.1

- (i) Down Key x 9 times for EVO-1212F/1212F-HW/1224F/1224F-HW
 - (ii) Down Key x 10 times for EVO-2212/2212E/3012/3012E/2224/2224E/4024/4024E & EVO-4248SP
- For programming options, see Table 4.9:
- Screen No. 10 (Column 1) for EVO-1212F/1212F-HW/1224F/1224F-HW
 - Screen No. 11 (Column 2) for EVO-2212/2212E/3012E/2224/2224E/4024/4024E & EVO-4248SP

SECTION 5 | SD Card

5.4.2 Uploading Saved Parameters

If there is a “xxx_yyy.cfg” file in the SD card with stored programmed parameters, then on inserting the card, the Remote Control will ask to upload the Config File. Press Enter Button to confirm or Back Button to cancel.

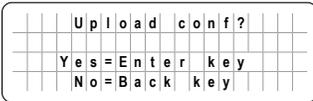

- Asks to confirm or cancel uploading of saved parameters.
- Choose Yes by pressing Enter Key.

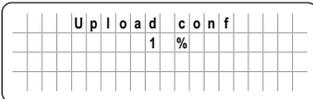

Configuration uploading.

SECTION 6 | Monitoring of Operation Using LED and Buzzer

Table 6.1 LED & BUZZER INDICATIONS FOR OPERATION MONITORING			
Status	Blue LED "Status"	Red LED "Fault"	Buzzer (See Note 1)
Seen during Power-On Sequence (See Section 3.2.1)	Blink 3 times and then turn off	OFF	OFF
Seen during Power-Off Sequence (See Section 3.2.2)	ON	ON	OFF
Normal charging	Blink once in 1 sec interval	OFF	OFF
Equalization charging	Blink once in 1 sec interval	OFF	OFF
Inverting	ON	OFF	Beep once in 3 sec interval (Default OFF)
Low battery alarm	ON	Blink once in 1 sec interval	Beep once in 1 sec interval
Power saving	Blink once in 3 sec interval	OFF	OFF
Standby	Blink once in 5 sec interval	OFF	OFF
Fault	OFF	ON	ON

NOTE: Buzzer is available only in EVO™ Inverter/Charger. There is no buzzer in Remote Control EVO-RC-PLUS.

SECTION 7 | Fault Messages and Troubleshooting Guide



CAUTION!

The cause of the fault should be removed before the unit is restarted.



ATTENTION!

La cause de la panne doit être retiré avant un redémarrage de l'appareil.

TABLE 7.1 FAULT MESSAGES AND TROUBLESHOOTING GUIDE

**NOTES: 1. Please see Table 6.1 for LED indications in EVO-RC-PLUS and buzzer indications in EVO™ Inverter/Charger
2. Buzzer is available only in EVO™ Inverter/Charger. There is no buzzer in Remote Control EVO-RC-PLUS**

Srl. No	Fault Message	Symptoms and Troubleshooting
1	Battery low voltage!	<ul style="list-style-type: none"> • EVO™ is in "FAULT MODE" because the battery voltage has dropped to the set lower threshold of "BATT LOW VOLTAGE" (Section 4.4.2.9) • When the battery voltage drops to the threshold of parameter "BATT LOW VOLTAGE" (Section 4.4.2.9), activation of this fault protection is initiated. The Red LED marked "Fault" will flash once per second and the buzzer in the EVO™ will beep once per second. <i>The Inverter Section will continue to operate normally, and the Blue LED marked "Status" will continue to be ON steady</i> (NOTE: Fault message "Battery low voltage!" will not be displayed during this time) • If the battery voltage stays at or below the threshold of "BATT LOW VOLTAGE" (Section 4.4.2.9) for duration equal to parameter "LV DETECT TIME" (See Section 4.4.2.10), only the Inverter Section will be switched OFF and fault message "Battery low voltage!" will be displayed. The Red LED marked "Fault" will now change to steady ON, the Blue LED marked "Status" will switch OFF and the buzzer in EVO™ will now beep steady. <i>The unit will get locked in this condition and will be required to be switched off as follows:</i> <ul style="list-style-type: none"> ○ The unit will automatically switch off after expiry of time set by parameter "LV CUT OFF TIME" (See Section 4.4.2.11). <i>[LCD Display / LED / Buzzer will be OFF]</i>, or ○ In case the time set by parameter "LV CUT OFF TIME" (See Section 4.4.2.11) has not expired, switch off the unit manually (See Section 3.2.2) • While in "Battery low voltage!" fault condition, if qualified AC input is made available before expiry of time set by parameter "LV CUT OFF TIME" (Section 4.4.2.11), the unit will automatically reset to "Charging Mode" <i>provided the battery voltage is (i) >9V for EVO-1212F/1212F-HW/2212/2212E/ 3012/3012E or, (ii) >18V for EVO-1224F/1224F-HW/2224/2224E/4024/4024E or, (iii) >36V for EVO-4248SP</i> <ul style="list-style-type: none"> ○ <i>In case it is desired that the unit should not switch off due to "Battery low fault!" condition after expiry of time set by parameter "LV CUT OFF TIME" (Section 4.4.2.11) but should automatically reset to "Charging Mode" on availability of qualified AC input voltage with battery voltage (i) >9V for EVO-1212F/1212F-HW/2212/2212E/ 3012/3012E or, (ii) >18V for EVO-1224F/1224F-HW/2224/2224E/4024/4024E or, (iii) >36V for EVO-4248SP, time value of parameter "LV CUT OFF TIME" should be changed to 0 sec (Refer to Section 4.4.2.9.2)</i> • If the batteries are charged by external charger connected directly to the batteries or through the External Charger Input (3, 4 in Fig 2.1 in EVO™ Owner's Manual) and the battery voltage recovers to the set threshold of parameter "RESET VOLTAGE" (Section 4.4.2.7) before the expiry of time set by parameter "LV CUT OFF TIME" (Section 4.4.2.11) while in "Battery low voltage!" fault condition, the Inverter Section will restart and "Battery low voltage!" fault condition will be cleared.

SECTION 7 | Fault Messages and Troubleshooting Guide

Srl. No	Fault Message	Symptoms and Troubleshooting
2	Battery ultra low voltage!	<ul style="list-style-type: none"> • EVO™ is in FAULT MODE because the battery voltage has <i>dropped momentarily for 1 ms</i> to (i) 9V or below for EVO-1212F/1212F-HW/2212/2212E/ 3012/3012E or, (ii) 18V or below for EVO-1224F/1224F-HW/2224/2224E/4024/4024E or (iii) 36V or below for EVO-4248SP. • The Inverter Section will be switched OFF and message "Battery ultra low voltage!" will be displayed. Red LED marked "Fault" will be steady ON, Blue LED marked "Status" will be switched OFF and the buzzer in EVO™ will beep steady. <i>The unit will get locked in this condition and will be required to be switched off as follows:</i> <ul style="list-style-type: none"> ○ The unit will automatically switch off after expiry of time set by parameter "LV CUT OFF TIME" (Section 4.4.2.11) [LCD display / LED / Buzzer will be OFF] or, ○ In case the time set by parameter "LV CUT OFF TIME" (Section 4.4.2.11) has not expired, switch off the unit manually (See Section 3.2.2) • While in "Battery ultra low voltage!" fault condition, if qualified AC input is made available before expiry of time set by programming parameter "LV CUT OFF TIME" (Section 4.4.2.11), the unit will automatically reset to "Charging Mode" <i>provided the battery voltage is (i) >9V for EVO-1212F/1212F-HW/2212/2212E/ 3012/3012E or, (ii) >18V for EVO-1224F/1224F-HW/2224/2224E/4024/4024E or, (iii) >36V for EVO-4248SP</i> <ul style="list-style-type: none"> ○ In case it is desired that the unit should NOT switch off due to "Battery ultra low voltage!" fault condition after expiry of time set by parameter "LV CUT OFF TIME" (Section 4.4.2.11) but should automatically reset to "Charging Mode" on availability of qualified AC input voltage with battery voltage (i) >9V for EVO-1212F/1212F-HW/2212/2212E/ 3012/3012E or, (ii) >18V for EVO-1224F/1224F-HW/2224/2224E/4024/4024E or, (iii) >36V for EVO-4248SP, the value of time set by parameter "LV CUT OFF TIME" should be changed to 0 sec (Refer to Section 4.4.2.9.2) • If the batteries are charged by external charger connected directly to the batteries or through the External Charger Input (3, 4 in Fig 2.1 in the EVO™ Owner's Manual) and the battery voltage recovers to the set threshold of parameter "RESET VOLTAGE" (Section 4.4.2.7) before the expiry of time set by parameter "LV CUT OFF TIME" (Section 4.4.2.11) while in "Battery ultra low voltage!" fault condition, the Inverter Section will restart and "Battery ultra low voltage!" fault condition will be cleared. <p>NOTE:</p> <p>Momentary low voltage threshold of (i)9V or lower for 1 ms for EVO-1212F/1212F-HW/2212/2212E/ 3012/3012E or, (ii)18V or lower for 1 ms for EVO-1224F/1224F-HW/2224/2224E/4024/4024E or, (iii) 36V or lower for EVO-4248SP that triggers "Battery ultra low voltage!" fault is likely to be reached under the following operating conditions:</p> <ul style="list-style-type: none"> a) The threshold of parameter "BATT LOW VOLTAGE" (Section 4.4.2.9) has been set at very low Depth of Discharge – slightly above the lower programming limit of (i)9V for EVO-1212F/1212F-HW/2212/ 3012/3012E, (ii)or slightly above 18V for EVO-1224F/1224F-HW/2224/2224E/4024/4024E or, (iii) slightly above 48V for EVO-4248SP. When the battery voltage approaches this low level of discharge, <i>its internal resistance will be considerably higher</i> as compared its internal resistance at higher State of Charge b) AC load(s) being powered are of a type that draw very high starting surge current spikes. Examples of such types of loads are (i) Switched Mode Power Supply (SMPS) based devices like Battery Chargers / AC to DC Adapters/ AC to DC Drivers for LEDs (iii) Compact Fluorescent Lamps (CFL), (iv) Quartz Lamps, (v) Ceramic Heaters, (vi) Compressors, (vii) Motors and (viii) Laser Printers etc. c) When the above type of AC loads [See (b) above] are switched on in Inverting Mode, the high starting surge current spikes will produce considerably higher voltage drop across higher internal resistance of the battery because of operation at deeply discharged level approaching threshold set by parameter "BATT LOW VOLTAGE" threshold (Section 4.4.2.9). When this momentary drop is equal to 9V/18V/36V or lower, the unit enters "Battery ultra low voltage!" fault condition

SECTION 7 | Fault Messages and Troubleshooting Guide

Srl. No	Fault Message	Symptoms and Troubleshooting
3	Battery over voltage!	<p>EVO™ Inverter/Charger is in FAULT MODE because the battery voltage has risen to the set upper threshold of "BATT OVER VOLTAGE" (Section 4.4.2.6)</p> <p>(a) AC input is not available and EVO™ Inverter/Charger is operating in Inverting Mode:</p> <ul style="list-style-type: none"> There will be no AC output because the Inverter Section will be switched OFF. The Blue LED marked "Status" will be switched OFF and the Red LED marked "Fault" will be steady ON. The buzzer in EVO™ Inverter/Charger will beep steady The fault will be cleared automatically when the battery voltage drops to 0.5V below the set upper threshold of "BATT OVER VOLT" (Section 4.4.2.6) <p>(b) AC input is available and EVO™ Inverter/Charger is operating in Charging Mode:</p> <ul style="list-style-type: none"> There will be no AC output or charging because the Transfer Relay will be de-energized and PWM drive to the Inverter Section will be switched OFF. The fault will be cleared automatically when the battery voltage drops to 0.5V below to the set upper threshold of "BATT OVER VOLT" (Section 4.4.2.6). The EVO™ Inverter/Charger will restart in Inverting Mode, synchronize with the AC input and then, the Transfer Relay will be energized to transfer to AC input at zero crossing. The unit will, thus, resume operation in "Charging Mode"
4	Input over current!	<p> INFO</p> <p>This FAULT MODE will be activated only when parameter "INPUT OC PROTECT" has been set to option "1=shutdown" (See Section 4.5.2.11 for additional details).</p> <p>EVO™ Inverter/Charger is in FAULT MODE because the input current being drawn from the AC input source (Input current = Charging Current + Pass Through Current to the load) is 1A more than the set threshold of " GRID MAX CURRENT" (Section 4.5.2.2) / "GEN MAX CURRENT" (Section 4.5.2.3) for 5 seconds (<i>current is sampled every 33.3 μs</i>).</p> <ul style="list-style-type: none"> There will be no AC output because the Transfer Relay will be de-energized, charging will be stopped and PWM drive to the Inverter Section will be switched OFF. The Blue LED marked "Status" will be switched OFF and the Red LED marked "Fault" will be steady ON. The buzzer in EVO™ Inverter/Charger will beep steady EVO™ Inverter/Charger will be latched in OFF condition and will require manual reset by powering OFF, waiting for 1 minute and then powering ON again The set threshold of " GRID MAX CURRENT" (Section 4.5.2.2) / "GEN MAX CURRENT" (Section 4.5.2.3) should match the breaker capacity of the AC input source / AC input Branch Circuit. If AC input current capacity cannot be increased, reduce the AC load / "BULK CURRENT" (Section 4.4.2.1) accordingly.
5	Output over current!	<p>EVO™ Inverter/Charger is in FAULT MODE because the instantaneous output current being drawn by the AC load in Inverting Mode is 330% of the rated value of the EVO™ Inverter/Charger for 2 samples (<i>current is sampled every 33.3 μs</i>).</p> <ul style="list-style-type: none"> There will be no AC output because the Inverter Section will be switched OFF. The Blue LED marked "Status" will be switched OFF and the Red LED marked "Fault" will be steady ON. The buzzer in EVO™ Inverter/Charger will beep steady EVO™ Inverter/Charger will be latched in OFF condition and will require manual reset by powering OFF, waiting for 1 minute and then powering ON again Ensure that the maximum instantaneous surge current of the load is not more than 300% of the rated current of the EVO™ Inverter/Charger for 1 millisecond

SECTION 7 | Fault Messages and Troubleshooting Guide

Srl. No	Fault Message	Symptoms and Troubleshooting
6	<p>Output over load!</p> <p>Output over load 1!</p> <p>Output over load 2!</p> <p>Output over load 3!</p> <p>Output over load 4!</p>	<p>EVO™ Inverter/Charger is in FAULT MODE because of overload conditions in Inverting Mode:</p> <ul style="list-style-type: none"> There will be no AC output because the Inverter Section will be switched OFF. The Blue LED marked "Status" will be switched OFF and the Red LED marked "Fault" will be steady ON. The buzzer in EVO™ Inverter/Charger will beep steady EVO™ Inverter/Charger will be latched in OFF condition and will require manual reset by powering OFF, waiting for 1 minute and then powering ON again Ensure that overloading is limited to the specified limit <ul style="list-style-type: none"> <96 Vrms for 300 cycles for (i) EVO-1212F / 1212F / 1224F / 1224F-HW and (ii) EVO-2212 / 3012 / 2224 / 4024 <184 Vrms for 300 cycles for EVO-2212E / 3012E / 2224E / 4024E <96 Vrms (<u>Phase Voltage</u>) for 300 cycles for EVO-4248SP <p>Output power is over the Power Boost Rating (110%) for 30 min</p> <p>Output power is over the Power Boost Rating</p> <ul style="list-style-type: none"> 120% for 10 min for (i) EVO-1212F / 1212F / 1224F / 1224F-HW and (ii) EVO-4248SP 120% for 5 min for EVO-2212 / 2212E / 3012 / 3012E / 2224 / 2224E / 4024 / 4024E <p>Output power is over the Power Boost Rating (140%) for 30 seconds</p> <ul style="list-style-type: none"> 140% for 1 min for (i) EVO-1212F / 1212F / 1224F / 1224F-HW and (ii) EVO-4248SP 140% for 30 sec for EVO-2212 / 2212E / 3012 / 3012E / 2224 / 2224E / 4024 / 4024E <p>Output power is over the Power Boost Rating (150%) for 5 seconds</p> <ul style="list-style-type: none"> 150% for 30 sec for (i) EVO-1212F / 1212F / 1224F / 1224F-HW and (ii) EVO-4248SP 150% for 5 sec for EVO-2212 / 2212E / 3012 / 3012E / 2224 / 2224E / 4024 / 4024E
7	<p>Output short circuit!</p>	<p>EVO™ Inverter/Charger is in FAULT MODE because there is a short circuit on the output side in Inverter Mode. Short circuit protection is activated as follows:</p> <p>(i) <i>EVO-1212F/1212F-HW/1224F/1224F-HW</i>: The output current has exceeded the value of the rated output current leading to the output voltage dropping to <15 Vrms for 6 cycles</p> <p>(ii) <i>EVO-2212/3012/2224/4024 and EVO-2212E/3012E/2224E/4024E</i>: The output current has exceeded the rated output current leading to the output voltage dropping to <15 Vrms for 6 cycles</p> <p>(iii) <i>EVO-4248SP</i>: The output current (<u>Phase Current</u>) has exceeded the rated current leading to the Phase Voltage dropping to <15 Vrms for 6 cycle</p> <ul style="list-style-type: none"> There is no AC output because the Inverter Section has been switched OFF. The Blue LED marked "Status" will be switched OFF and the Red LED marked "Fault" will be steady ON. The buzzer in EVO™ Inverter/Charger will beep steady EVO™ Inverter/Charger will be latched in OFF condition and will require manual reset by powering OFF, waiting for 1 minute and then powering ON again <p>NOTE: If there is short circuit condition in Charging Mode i.e. when AC input is available, short circuit condition on the output side will trip the AC input breaker. The load will be transferred to the Inverter Section and the Inverter Section will then see short circuit condition and will shut down as described above</p>
8	<p>Output failure!</p>	<p>EVO™ Inverter/Charger is in FAULT MODE because AC input from Grid / Generator has been connected to the AC Output terminals by mistake. 10VAC or above seen at the AC Output Terminals at the time of boot up of EVO™ Inverter/Charger will activate this protection</p> <ul style="list-style-type: none"> The Blue LED marked "Status" will be switched OFF and the Red LED marked "Fault" will be steady ON. The buzzer in EVO™ Inverter/Charger will beep steady EVO™ Inverter/Charger will be latched in OFF condition and will require manual reset by powering OFF, waiting for 1 minute and then powering ON again <p>Check the connection. If there is 10V over at the output terminal, remove the connection.</p>

SECTION 7 | Fault Messages and Troubleshooting Guide

Srl. No	Fault Message	Symptoms and Troubleshooting
9	Transformer over heat!	<p>EVO™ Inverter/Charger is in FAULT MODE because the main Bidirectional Transformer in the EVO™ Inverter/Charger has overheated to 150°C</p> <ul style="list-style-type: none"> The Blue LED marked "Status" will be switched OFF and the Red LED marked "Fault" will be steady ON. The buzzer in EVO™ Inverter/Charger will beep steady If in Inverting Mode, Inverter Section will be switched OFF. If in Charging Mode, the Transfer Relay will be de-energized and the Inverter Section will be switched OFF. Check that the fans are working properly, there is no blockage of air suction and discharge vents, adequate cool replacement air is available and the ambient temperature is within the limits. Reduce the load / "BULK CURRENT" (Section 4.4.2.1) The fault will be cleared when the transformer has cooled down to 80°C
10	Heat sink over heat!	<p>EVO™ Inverter/Charger is in FAULT MODE because the internal heat sink in the EVO™ Inverter/Charger has overheated to (i)100°C for EVO-1212F/1212F-HW/1224F/1224F-HW/4248SP or, (ii)70°C for EVO-2212/2212E/3012/3012E/2224/2224E/4024/4024E</p> <ul style="list-style-type: none"> The Blue LED marked "Status" will be switched OFF and the Red LED marked "Fault" will be steady ON. The buzzer in EVO™ Inverter/Charger will beep steady If in Inverting Mode, Inverter Section will be switched OFF. If in Charging Mode, the Transfer Relay will be de-energized and the Inverter Section will be switched OFF. Check that the fans are working properly, there is no blockage of air suction and discharge vents, adequate cool replacement air is available and the ambient temperature is within the limits. Reduce the load and "BULK CURRENT" (Section 4.4.2.1) The fault will be cleared when the heat sink has cooled down to (i)60°C for EVO-1212F/1212F-HW/1224F/1224F-HW/4248SP or, (ii)40°C for EVO-2212/2212E/3012/3012E/2224/2224E/4024/4024E
11	SD card unusable!	<ul style="list-style-type: none"> Data logging will not start. Check that the format is FAT16/FAT32. Check that the capacity is not more than 32 GB. Re-format the card.
12	SD card read error!	<ul style="list-style-type: none"> Data logging stops. Remove and re-insert the card.
13	SD card write error!	<ul style="list-style-type: none"> Data logging stops. Remove and re-insert the card.
14	SD card full!	<ul style="list-style-type: none"> Data logging stops. Move or delete files or re-format the card.
15	WRITE FAILURE!	<ul style="list-style-type: none"> The entered value of programmable parameter could not be written. Call Technical Support.
16	OUT OF RANGE!	<ul style="list-style-type: none"> The entered value of programmable parameter is out of the programmable range. Change parameter value to within the specified range.

SECTION 8 | Specifications

8.1 SPECIFICATIONS

ITEM	DESCRIPTION / SPECIFICATIONS	
Compatible Inverter/Chargers	EVO™ Series Inverter/Charger	
Display	LCD Display	4 Rows, 20 Character each, Alpha-Numeric LCD Display
	LED Indicators	Blue (Status); Red (Fault)
Input/Output Jacks	RJ-45	Modular Jack, 8P8C
	RJ-12	Modular Jack, 6P6C
Cable Set Provided	RJ-45 Data Cable (Straight Wired); 10 Meters / 33 ft	
Environment	Operating Temperature Range	-20°C to 60°C
Dimensions	(W X H X D), mm	160 x 114.2 x 35.5
	(W X H X D), inches	6.3 x 4.5 x 1.4
Weight	Weight without cable	0.3 kg / 0.6 lb
	Weight with cable	0.4 kg / 1.0 lb

SECTION 9 | Warranty

3 YEAR LIMITED WARRANTY

EVO-RC-PLUS manufactured by Samlex America, Inc. (the "Warrantor") is warranted to be free from defects in workmanship and materials under normal use and service. The warranty period is 3 years for the United States and Canada, and is in effect from the date of purchase by the user (the "Purchaser").

Warranty outside of the United States and Canada is limited to 6 months. For a warranty claim, the Purchaser should contact the place of purchase to obtain a Return Authorization Number.

The defective part or unit should be returned at the Purchaser's expense to the authorized location. A written statement describing the nature of the defect, the date of purchase, the place of purchase, and the Purchaser's name, address and telephone number should also be included.

If upon the Warrantor's examination, the defect proves to be the result of defective material or workmanship, the equipment will be repaired or replaced at the Warrantor's option without charge, and returned to the Purchaser at the Warrantor's expense. (Contiguous US and Canada only) using a carrier of the warrantor's choice.

Warranty service shall be performed only by the Warrantor. Any attempt to remedy the defect by anyone other than the Warrantor shall render this warranty void. The warranty does not apply to units with a serial number that has been altered, removed or modified in any way.

There is no warranty for defects or damages to equipment or parts caused by:

- Installation, alternation, inspection or removal
- Normal wear and tear
- Abuse or misuse of the equipment including exposure to excessive heat, salt or fresh water spray, or water immersion
- Corrosion, fire, lightening, biological infestations or Acts of God
- Repairs attempted by anyone other than the Warrantor
- Improper use, contrary to operational instructions provided in product manual
- Shipping or transport

No other express warranty is hereby given and there are no warranties which extend beyond those described herein. This warranty is expressly in lieu of any other expressed or implied warranties, including any implied warranty of merchantability, fitness for the ordinary purposes for which such goods are used, or fitness for a particular purpose, or any other obligations on the part of the Warrantor or its employees and representatives.

There shall be no responsibility or liability whatsoever on the part of the Warrantor or its employees and representatives for injury to any persons, or damage to person or persons, or damage to property, or loss of income or profit, or any other consequential or resulting damage which may be claimed to have been incurred through the use or sale of the equipment, including any possible failure of malfunction of the equipment, or part thereof. The Warrantor assumes no liability for incidental or consequential damages of any kind.

Samlex America Inc. (the "Warrantor")

www.samlexamerica.com

Contact Information

Toll Free Numbers

Ph: 1 800 561 5885

Fax: 1 888 814 5210

Local Numbers

Ph: 604 525 3836

Fax: 604 525 5221

Website

www.samlexamerica.com

USA Shipping Warehouses

Kent, WA

Plymouth, MI

Canadian Shipping Warehouse

Richmond, BC

Email purchase orders to
orders@samlexamerica.com



samlexamerica®